

# Vertical Contact Toaster

## Model VCT-1000 Owner's manual

Manufacturing Numbers:

9211032



# Contents

**Overview**..... 2  
 Before Use ..... 2  
 In Case of Damage ..... 2  
 Website ..... 2  
**Service/Technical Assistance**..... 2  
 In Case of Damage ..... 2  
 Equipment Information to Save..... 2  
 Authorized Service Agency ..... 2  
**Safety Information** ..... 3  
 Installation ..... 3  
 Maintenance..... 3  
 Service ..... 3  
**Specifications** ..... 4  
 Electrical Ratings ..... 4  
 Electrical Cord & Plug Configuration..... 4  
**Installation**..... 5  
 Unpacking ..... 5  
 Assembling the Unit ..... 5  
**Operating Instructions** ..... 6  
**Safety Features**..... 6  
 Hi-Limit Reset Button ..... 6  
**Daily Maintenance** ..... 7  
 Replacing the Release Sheet..... 7  
 Checking the Conveyor Belt Chains ..... 8  
 Measuring Conveyor belt Chains ..... 8  
 Replacing Conveyor belt Chains..... 9  
 Checking the Roller Tensioners ..... 9  
**Troubleshooting** ..... 10  
**Wiring Diagram** ..... 12  
**Parts Identification** ..... 13  
**Replacement Parts** ..... 14  
 Parts List ..... 14  
 Exploded Diagram 1..... 16  
 Exploded Diagram 2..... 17  
 Exploded Diagram 3..... 18  
 Optional Kits..... 19  
**Notes**..... 20  
**Limited Warranty** ..... 22

# Overview

This unit is intended to be used for commercial applications, for example: in kitchens of restaurants, canteens, hospitals and in commercial enterprises such as bakeries, butcheries, etc., But not for continuous mass production of food.

## Before Use

This manual contains safety, installation, and operating procedures for the unit. Read and understand it completely before installing or operating the unit. Keep this document for reference. If the unit changes ownership, this manual must accompany it.

## In Case of Damage

If the unit arrives damaged, file a claim with the carrier immediately. Save all packing materials when filing a claim. Freight damage claims are the responsibility of the purchaser and are not covered under warranty.

## Website

[www.antunes.com](http://www.antunes.com)

# Service/Technical Assistance

## In Case of Damage

If any parts are missing or damaged, problems with the installation or operation of this product contact Antunes Customer Service immediately at +1-877-392-7856 (toll free).

Fill in the information in the next section and have it ready when calling for assistance. The serial number is on the specification sticker located on the system.

## Equipment Information to Save

Purchased from:

---

Date of purchase:

---

Model number:

---

Serial number:

---

Manufacturing number:

---

## Authorized Service Agency

Name:

---

Phone No:

---

Address:

---

## Safety Information

### Installation

- Read and understand all instructions before installing or using the unit.
- Install this unit to comply with the basic plumbing code of the Building Officials and Code Administrators, Inc. (BOCA) and the Food Service Sanitation Manual of the Food and Drug Administration (FDA).
- Install and locate the equipment only for its intended use as described in this manual.

### WARNING

**ELECTRICAL SHOCK HAZARD.**  
Failure to follow the instructions in this manual could result in serious injury or death.

Do not modify the power supply cord plug. If it does not fit the outlet, have a proper outlet installed by a qualified electrician.

**Electrical ground is required on this appliance.**

**Check with a qualified electrician if you are unsure if the appliance is properly grounded.**

**Do NOT use an extension cord with this product.**

**The unit should be grounded according to local electrical codes to prevent the possibility of electrical shock. It requires a grounded receptacle with separate electrical lines, protected by fuses or circuit breaker of the proper rating.**

**NEVER unplug the power cord while the unit is running. Use the proper shutdown procedure before unplugging the power cord.**

## Operation

- The unit is furnished with a properly grounded cord connector. Do not attempt to defeat the grounded connector.
- Do not operate the unit if it has been damaged or dropped, if it has a damaged cord or plug, or if it is not working properly.
- Do not block or cover any openings on the equipment.
- Do not immerse the cord, unit, or plug in water.
- Keep the cord away from heated surfaces.
- Do not allow the cord to hang over the edge of a table or counter. This appliance is not to be used by persons (including children) with reduced physical, sensory or mental capabilities, or lack of experience and knowledge unless they have been given supervision or instruction.
- Children being supervised are not to play with the appliance.
- Bread may burn. Therefore toasters must not be used near or below curtains or other combustible walls and materials. Failure to maintain safe operating distances may cause discoloration or combustion.

## Maintenance

- Do not use abrasive materials; they can damage the unit's stainless steel finish.
- Do not use corrosive chemicals in this equipment.
- Chlorides or phosphates in cleaning agents (e.g., bleach, sanitizers, degreasers, and detergents) can permanently damage stainless steel equipment. The damage is usually in the form of discoloration, dulling of the metal surface finish, pits, voids, holes, or cracks. This damage is permanent and is not covered by warranty.
- Always use a soft, damp cloth for cleaning. Rinse with clear water and wipe dry. When required, always rub in the direction of metal polish lines.
- Routine cleaning should be performed daily with soap and water.
- Rub off finger marks and smears using soap and water.
- Do not clean the unit with a water jet or steam cleaner.

## Service

- Inspection, testing, and repair of electrical equipment must be performed only by qualified service personnel.
- To avoid possible personal injury and/or damage to the unit, all inspections, tests, and repair of electrical equipment should be performed by qualified personnel ONLY. Contact Antunes Technical Service for adjustment or repair.
- Turn the power off, unplug the power cord, and allow unit to cool to room temperature before performing any service or maintenance.
- If the supply cord is damaged, it must be replaced by the manufacturer, its service agent, or a similarly qualified person in order to avoid an electrical hazard.
- Cleaning and user maintenance shall not be made by children without supervision.

# Specifications

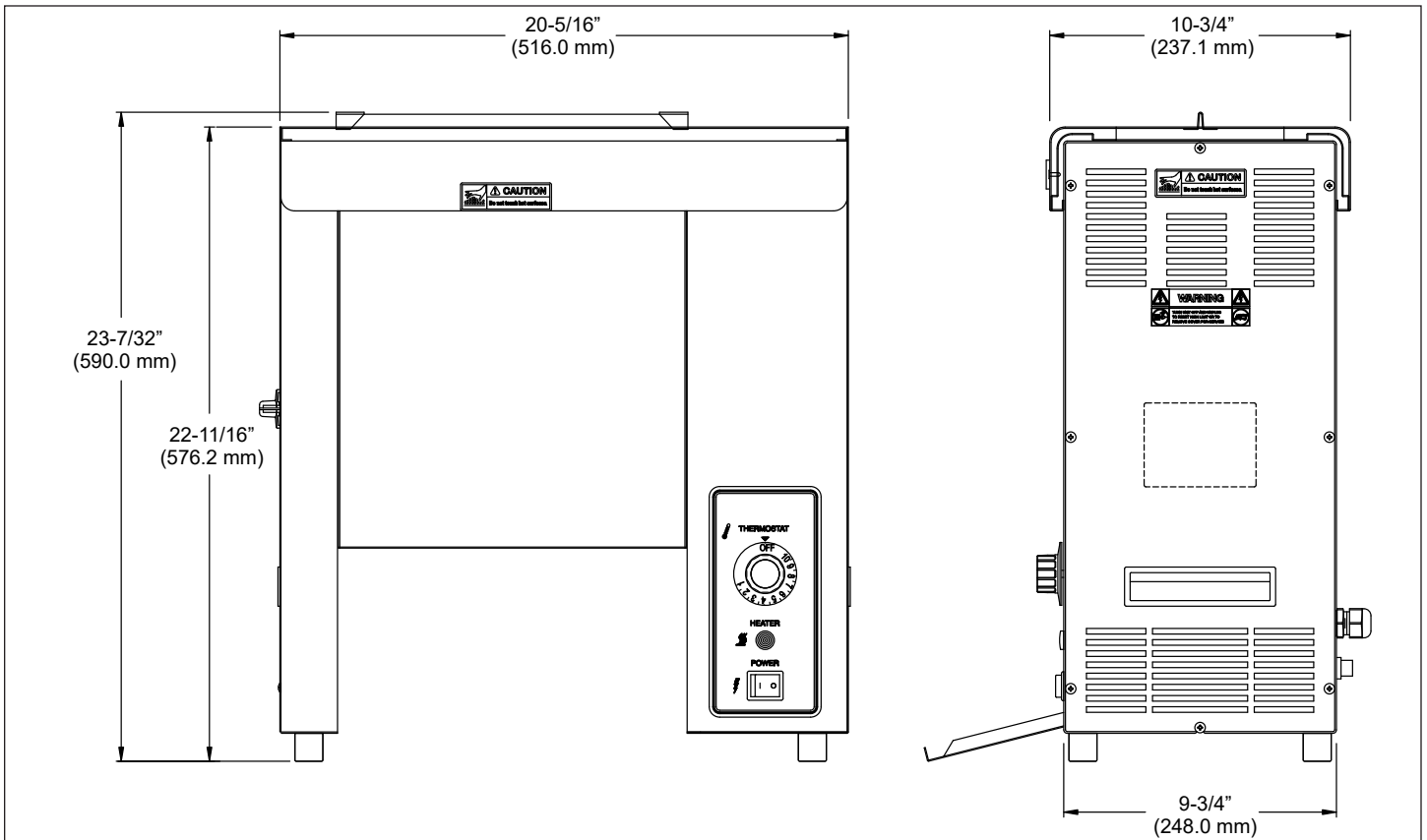

## Electrical Ratings

Model & Mfg. No.	Volts	Watts	Amp.	Hertz
VCT-1000CF 9211032 (No Butterwheel)	120	1800	15.0	50/60

## Electrical Cord & Plug Configuration

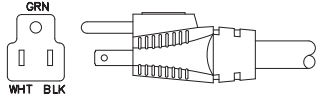
Model & Mfg. No.	Description	Configuration
VCT-1000CF 9211032 (No Butterwheel)	NEMA 5-15P, 15 Amp., 120 VAC, Non-locking (Assembly Only)	

# Installation

## Unpacking

1. Remove unit and all packing materials from shipping carton.
2. Open the large box. It should contain:
  - Bun Feeder (Figure 1)
  - Bun Chute (Figure 2)
  - Two Release Sheets (Figure 1)
  - Authorized Service Agency Directory
  - Owner's Manual
3. Remove all packing materials and protective coverings from the unit and parts.

**NOTE:** If any parts are missing or damaged, contact Antunes Customer Service IMMEDIATELY at +1-877-392-7856 (toll free).

## Assembling the Unit

**NOTE:** The factory has pre-installed a Release Sheet over the Platen (Figure 1). Verify that it is properly in place before proceeding.

1. Install the Bun Feeder (Figure 1) and Bun Chute (Figure 2).

**NOTE:** As of March 2017, the Interlock Switch was removed from use. If your toaster has the Interlock Switch, you will need to place the Heat Shield onto the toaster in order for the conveyors to turn. If your toaster does not have an Interlock Switch, the conveyors will turn as long as the unit is on.

**NOTE:** Check the Release Sheet to make sure it is not caught in the conveyor. Additional Release Sheets can be purchased through your Authorized Service Agency under P/N 7000249 (3-pack) or 7000250 (10-pack).

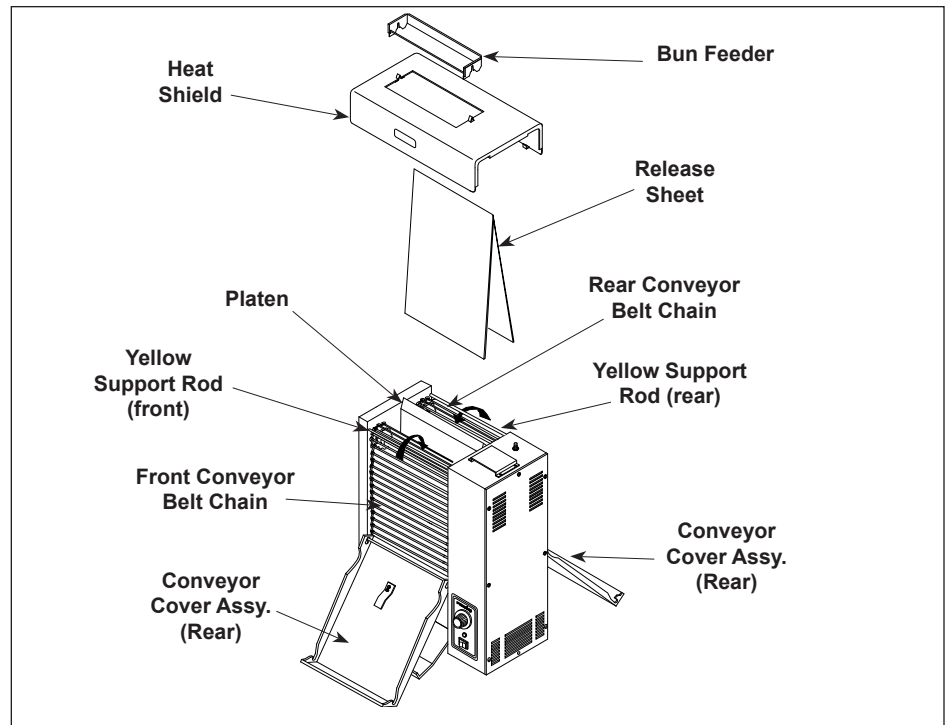

Figure 1. Toaster and Accessories

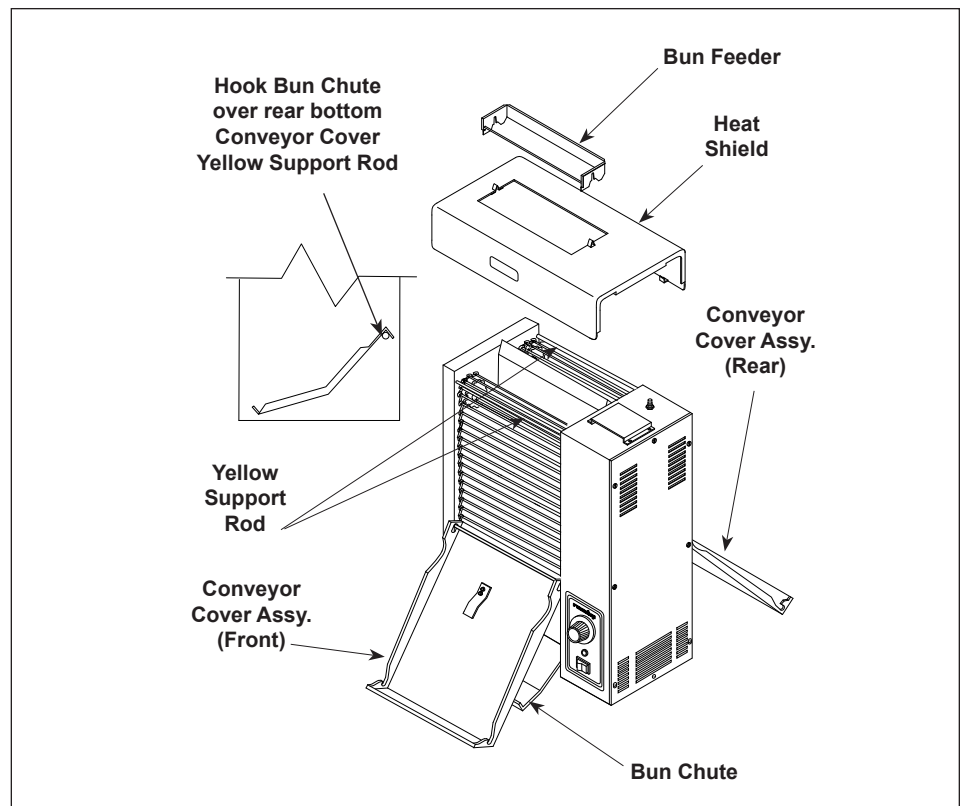

Figure 2. Installing Bun Chute

# Operating Instructions

1. Set the Bun Thickness Compression Knobs (Figure 4) to the desired settings.

**NOTE:** After initial run of 4-6 buns, adjust controls according to the desired finished product.

2. Turn the power on (Figure 3).
3. Turn the temperature control to 10 and allow the unit to warm up for 30 minutes.
4. Drop buns into toaster. Cut sides of heel and crown must face each other.
5. Toasted product will drop into the bun landing area (Figure 3).
6. Test at least 4 buns before putting toaster into service. Turn temperature control to lower setting for lighter toasting or to higher setting for darker toasting.
7. Turn the power off when finished toasting and follow the daily cleaning procedures.

## Safety Features

### Hi-Limit Reset Button

A Hi-Limit Control turns off electrical power to the heater if the unit overheats. To reset this control, allow 10-15 minutes for the unit to cool down, Remove the Protective Cap, and fully press the Reset Button located at the rear of the unit (Figure 3).

If the unit requires continuous resetting, contact your Authorized Service Agency.

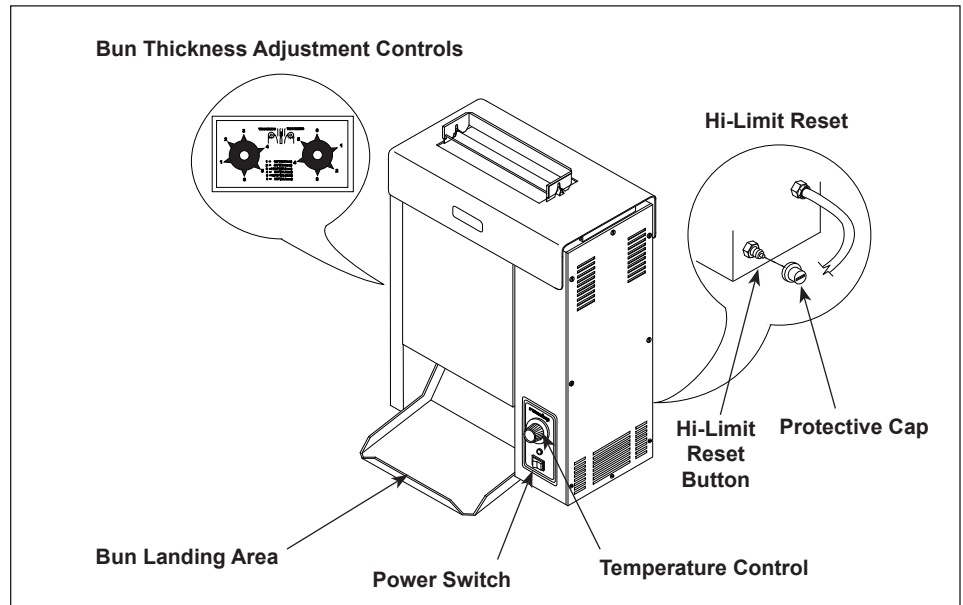

Figure 3. Toaster Controls

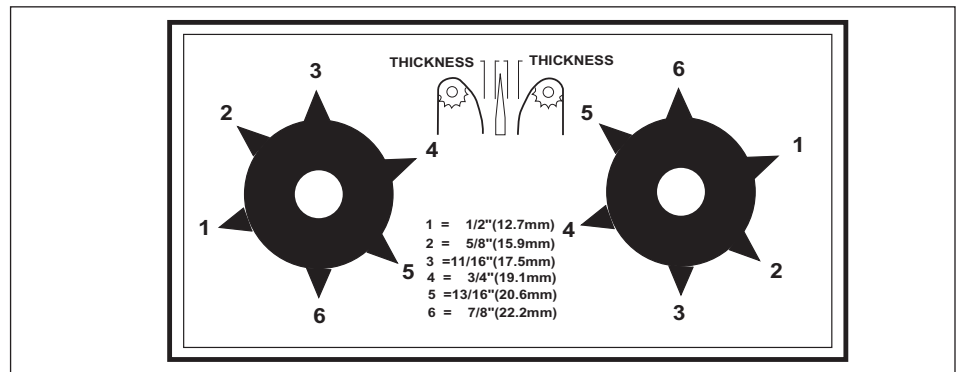

Figure 4. Bun Thickness Compression Knobs

## Daily Maintenance

**NOTE:** To prevent damage to the unit, do not use abrasive cleaners on the Release Sheet or belt wrap.

**NOTE:** Failure to use Release Sheets may result in damage to the unit and loss of warranty coverage.

### Tools Required:

- Heat-Resistant Gloves
  - Clean Towels
  - Multipurpose Detergent Solution
  - Sanitizer Solution
1. Turn the power off, unplug the power cord, and allow the unit to cool for 30 minutes.
  2. Put on heat resistant gloves. Remove the Bun Feeder, Heat Shield, and Bun Chute (Figure 1).
  3. Wipe the Bun Feeder, Heat Shield, and Bun Chute with a damp sanitized towel and allow them to air dry.
  4. Remove the Release Sheet and place it on a clean, flat dry surface.
  5. Wipe the silver side with a clean towel dampened with Multipurpose Detergent Solution immediately followed by a second clean towel dampened with sanitizer. Allow it to air dry before continuing.
  6. Once the silver side of the Release Sheet is dry, repeat Step 5 on the black side. If properly cleaned, the Release Sheet surface should be smooth to the touch when dry.
  7. Open the front Conveyor Cover and firmly wipe the Belt Wrap (if used) or Conveyor Belt Chain from left to right and top to bottom with a clean towel dampened with Multipurpose Detergent Solution immediately followed by a second clean towel dampened with sanitizer solution.
  8. Close the front Conveyor Cover, open the rear Conveyor Cover, and clean the Belt Wrap (if used) or Conveyor Belt Chain as described in Step 7.
  9. Close the rear Conveyor Cover and reinstall the Heat Shield. Then plug in the power cord, turn the unit on, count 10 seconds, then turn the unit off and unplug the unit. This will allow the uncleaned sections to be exposed.

**NOTE:** As of March 2017, the Interlock Switch was removed from use. If your toaster has the Interlock Switch, you will need to place the Heat Shield onto the toaster in order for the conveyors to turn. If your toaster does not have an Interlock Switch, the conveyors will turn as long as the unit is on.

10. Open the rear Conveyor Cover again, clean the newly exposed section of the Belt Wrap (if used) or the Conveyor Belt Chain in the same manner as before. Close the Conveyor Cover.
11. Open the front Conveyor Cover again and clean the newly exposed section of the Belt Wrap (if used) or Conveyor Belt Chain in the same manner as before.
12. Close the front Conveyor Cover and wipe down the outside of the toaster with a clean, damp, sanitized towel.
13. Install a new or clean Release Sheet, using the reverse side, by draping it over both sides of the Platen with the crease centered on the Platen.
14. Install the Bun Chute so the hooks are installed over the lower rear yellow Support Rod.
15. Install the Heat Shield with the Release Sheet retainer clips securely over the Release Sheet and Platen.
16. Reinstall the Bun Feeder and plug in the unit.

**NOTE:** Additional Release Sheets can be purchased through your Authorized Service Agency under P/N 7000249 (3-Pack) or 7000250 (10-Pack).

## Replacing the Release Sheet

**NOTE:** Depending on toaster usage and on how well it is cleaned daily, the Release Sheet should last between 45–60 days.

1. Remove and discard the Release Sheet.
2. Lay a new Release Sheet on a clean, dry surface and fold it in half lengthwise and gently crease it at the fold using only your fingers (Figure 5).
3. Install the Release Sheet just as you would after Daily Cleaning.

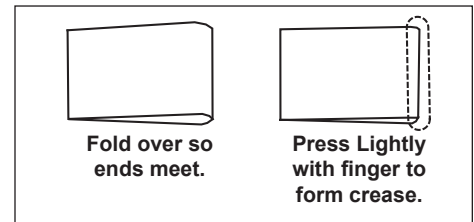

Figure 5. Folding the Release Sheet

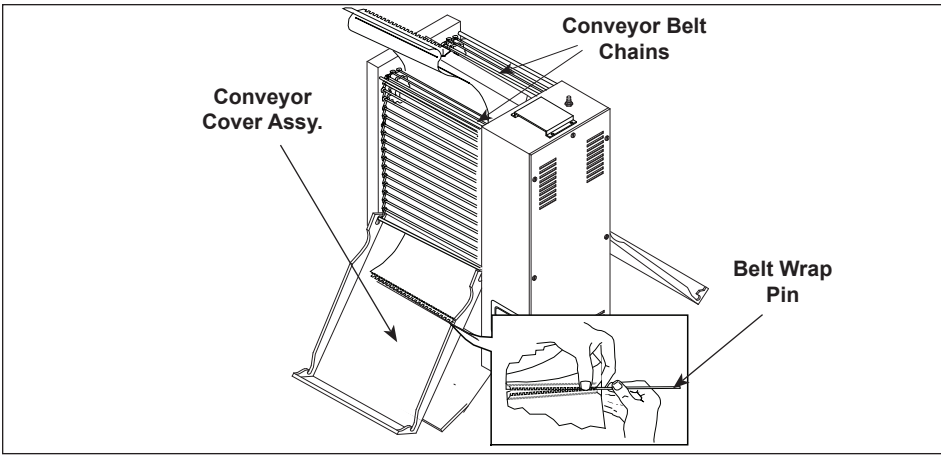

Figure 6. Removing Optional Belt Wrap

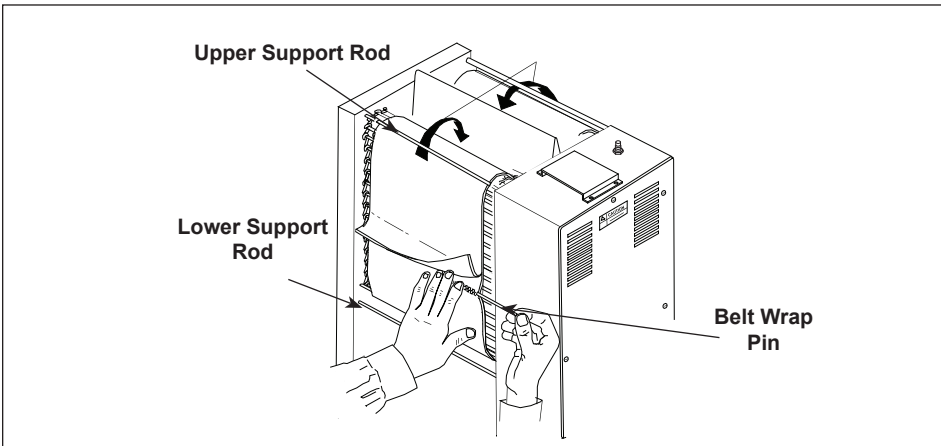

Figure 7. Installing Belt Wrap

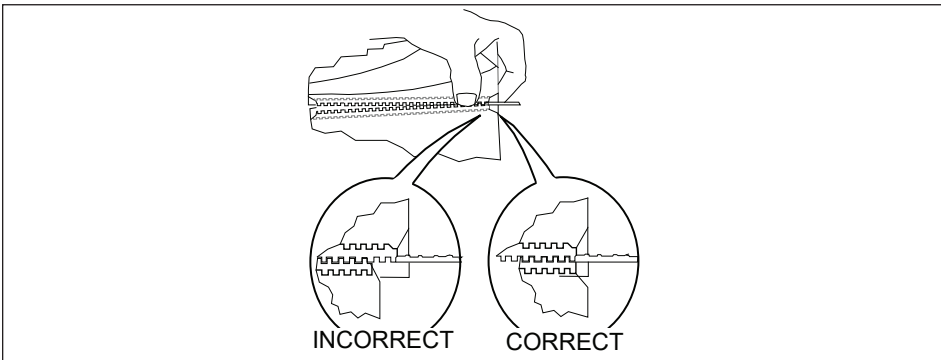

Figure 8. Aligning Belt Teeth

**NOTE:** Align the ends of the Belt Wrap properly (Figure 8) or the Belt Wrap may be damaged.

**NOTE:** Position the Belt Wrap inside the upper and lower yellow support rods or damage to the unit may occur.

## Checking the Conveyor Belt Chains

**NOTE:** The Bun Thickness Compression Knobs (Figure 4) must be set to “6 & 6” or “6 & F” prior to measuring or removing or reinstalling the Conveyor Belt Chains.

## Measuring Conveyor belt Chains

1. Turn the unit off, unplug the power cord, and allow the unit to cool.
2. Remove the Bun Feeder, Butter Wheel, Pan, and Heat Shield (Figure 1) and set the Bun Thickness Compression Knobs to 6 & 6 or 6 & F.
3. Open both Conveyor Covers and pull the Belt Wrap Pin out of the zipper (Figure 6).
4. Remove the Belt Wrap.
5. Facing the toaster, locate the approximate center-point of the Conveyor Chain.
6. Pull the Conveyor Chain away from the edge of the toaster (Figure 9).
7. Stand a U.S. Dime on end between the frame and the chain (Figure 9).
8. If the gap is significantly wider than the coin, REMOVE links as described below.
9. Disconnect the Conveyor Belt Chain by squeezing any two links together and unhooking both ends one link (Figure 10). Needle-nose pliers may be used.
10. Remove one 1/2” link from the belt.
11. Reassemble the Conveyor Belt Chain onto the sprockets as described in Replacing Conveyor Belt Chains.
12. Measure the gap again to ensure it is not too tight.
13. Check the opposite side of the toaster using the same steps.

**NOTE:** There are two small 1/2” links on each side of the Conveyor Belt Chain. The rest are large 3/4” links.

**NOTE:** If the Conveyor Belt Chain is too tight to be reassembled, remove an additional small 1/2” link and install a large 3/4” link in its place. This will shorten the Conveyor Belt Chain by 1/4” overall.



## Replacing Conveyor belt Chains

1. Turn the power off, unplug the power cord, and allow the unit to cool before proceeding.
2. Remove the Butter Wheel, Pan, and Heat Shield and set the Compression Control Knobs to 6 & 6 or 6 & F.
3. Open both Conveyor Covers and pull the Belt Wrap Pin out of the zipper.
4. Remove & discard old Belt Wrap(s).
5. Disconnect the Conveyor Belt Chain by squeezing any two links together and unhooking both ends of one link (Figure 10).
6. Place the replacement Conveyor Belt Chain on the top sprockets with hook ends down.

**NOTE:** The ends of the hooks must point down (Figure 10).

7. Wrap the Conveyor Belt Chain around the top and lower sprockets and connect by hooking both ends together.

**NOTE:** Make sure the Conveyor Belt Chain is installed under the Upper Support Rod and over the Lower Support Rod.

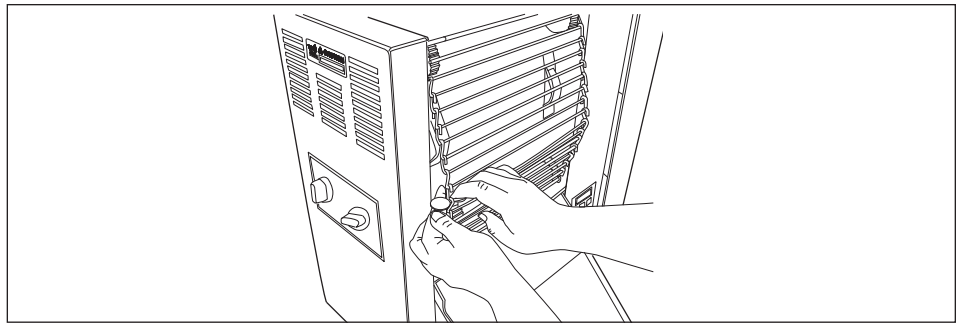

Figure 9. Removing Conveyor Belt Chain

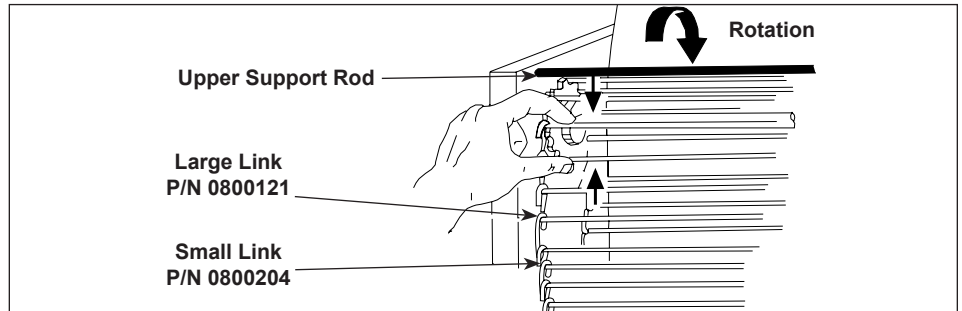

Figure 10. Removing Conveyor Belt Chain

## Checking the Roller Tensioners

### Measuring The Roller Tensioners

1. Measure the Roller Tensioner on both inner Conveyor Covers (Figure 11) using a U.S. Nickel.
2. The space between the inner Conveyor Cover and bottom of the Tensioner wheel should be  $13/16$ " (2.1 cm) or the height of a U.S. Nickel.
3. Adjust or replace any damaged ones as recommended.

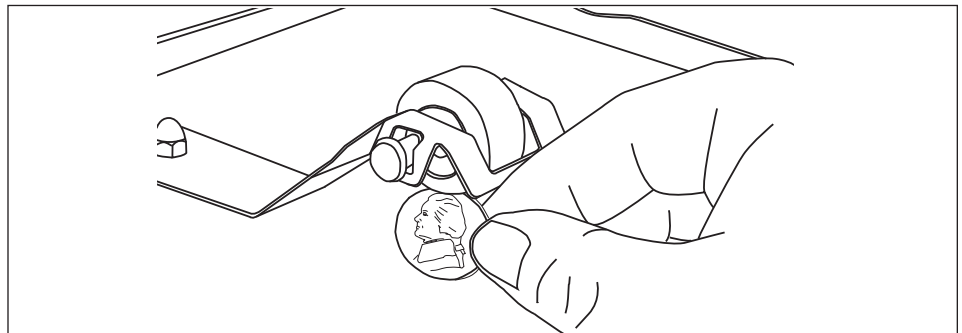

Figure 11. Measuring Roller Tensioner

## Replacing Roller Tensioners

1. Push down on retaining tab of the tensioner.
2. While keeping pressure on the retaining tab, slide the tensioner out of the retainer plate.
3. Replace the tensioner by sliding the new one into the retainer plate.

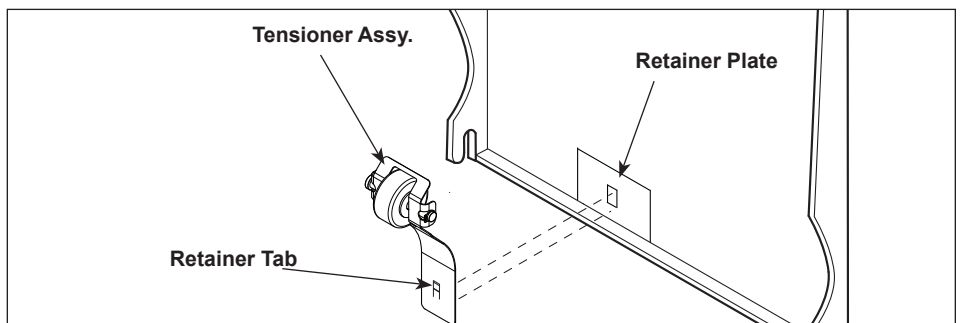

Figure 12. Replacing Roller Tensioner Assy.

## Troubleshooting

### WARNING

To avoid possible personal injury and/or damage to the unit, inspection, test and repair of electrical equipment should be performed by qualified service personnel. The unit should be unplugged when servicing, except when electrical tests are required. Use extreme care during electrical circuit tests. Live circuits will be exposed.

Problem	Possible Cause	Corrective Action
No heat and Conveyor Belt Chains do not move.	Toaster is installed incorrectly.	Perform the installation and operating procedures found in the Installation and Operation sections of this manual.
	Inoperable Power Cord or Power Switch.	Check receptacle for correct voltage (see the Specifications section of this manual). If necessary, contact your maintenance person or Authorized Service Agency for service.
	Hi-Limit Control is tripped.	Reset the Hi-Limit Control (see Figure 6 in the Operations section of this manual).
	Wiring problem.	Contact your maintenance person or Authorized Service Agency for service.
No heat but Conveyor Belt Chains move.	Wiring problem.	Contact your maintenance person or Authorized Service Agency for service.
	Inoperative Platen.	
	Inoperable Thermostat	
Platen is hot but Conveyor Belt Chains do not rotate.	Heat Shield not installed.	Install Heat Shield (Figure 2).
	Conveyor Safety Interlock Switch (if present) not activated by the Heat Shield.	Re-install the Heat Shield correctly so that the Heat Shield applies appropriate pressure on the Conveyor Safety Interlock Switch. If the Interlock Switch has failed, order kit 7001436 to remove and bypass the Interlock Switch.
	Spring Tensioner Assembly or Roller Tensioner is damaged or missing.	Replace Spring Tensioner or Roller Tensioners if damaged or missing.
	Conveyor Belt Chain links too loose.	Adjust Conveyor Belt Chain length as described in the Maintenance section of this manual.
	Inoperable Drive Motor.	Contact your maintenance person or Authorized Service Agency.
	Loose Drive Motor Sprocket Setscrew.	
	Drive Motor Chain has fallen off sprocket(s).	
	Inoperable Safety Interlock Switch.	
Conveyor Belts Chains hesitate to rotate and/or skip on sprockets.	Conveyor Belt Chains installed incorrectly.	Install Conveyor Belt Chains to match Figure 11. Be sure that the ends of the hooks are facing down.
	Conveyor Belt Chains too loose.	Adjust Conveyor Belt Chain length as described in the Maintenance section of this manual.
	Spring Tensioner Assembly or Roller Tensioner is damaged or missing.	Replace Spring Tensioner Assembly or Roller Tensioners if damaged or missing.

<b>Problem</b>	<b>Possible Cause</b>	<b>Corrective Action</b>
Product is over toasted, Platen heat is too high, or drop time is too slow.	Temperature set too high.	Set temperature control to a lower setting.
	Bun Thickness Compression Knobs set improperly.	Measure bun thickness and set Bun Thickness Compression Knobs correctly (Figure 7).
	Buns sticking on Release Sheet.	Clean or replace Release Sheet according to the procedure in the Maintenance section of this manual.
	Conveyor Cover Assembly not installed properly.	Re-install Conveyor Cover Assembly.
	Loose sprocket setscrews.	Check drive chain for kinks, broken or bent links, or other damage. Check motor sprocket and drive sprockets; tighten setscrew on flat of shaft if required. Check for damaged/worn sprocket and replace as required.
	Conveyor Belt Chain too loose.	Adjust Conveyor Belt Chain length as described in the Maintenance section of this manual.
	Spring Tensioner Assembly or Roller Tensioner is damaged or missing.	Replace Spring Tensioner Assembly or Roller Tensioner if damaged or missing.
Product is under toasted, Platen heat is too low, or drop time is too fast.	Bun Thickness Compression Knobs set improperly.	Measure bun thickness and set Bun Thickness Compression Knobs correctly (Figure 7).
	Wiring problem.	Contact your maintenance person or Authorized Service Agency for service.
	Inoperable Thermostat.	
	Conveyor Drive Motor inoperable or incorrect conveyor motor installed in toaster.	
Product is getting stuck or Conveyor Belt Chains stop when product is toasting.	Bun Thickness Compression Knobs Set improperly.	Measure bun thickness and set Bun Thickness Compression Knobs correctly.
	Release Sheet not cleaned properly or is missing.	Clean or replace Release Sheet as described in the Maintenance section of this manual..
	Conveyor Drive motor inoperative or incorrect conveyor motor installed in toaster.	Contact your maintenance person or Authorized Service Agency for service.
	Conveyor Drive Chain loose, worn, or broken. Loose motor drive sprocket.	Check drive chain for kinks, broken or bent links, or other damage. Check motor sprocket and drive sprockets, tighten setscrew on flat of shaft if required. Check for damaged/worn sprockets and replace as required.
	Conveyor Belt Chain too loose.	Adjust Conveyor Belt Chain length as described in the Maintenance section of this manual.
	Spring Tensioner Assembly or Roller Tensioner is damaged or missing.	Replace Spring Tensioner Assembly or Roller Tensioner if damaged or missing.

# Wiring Diagram

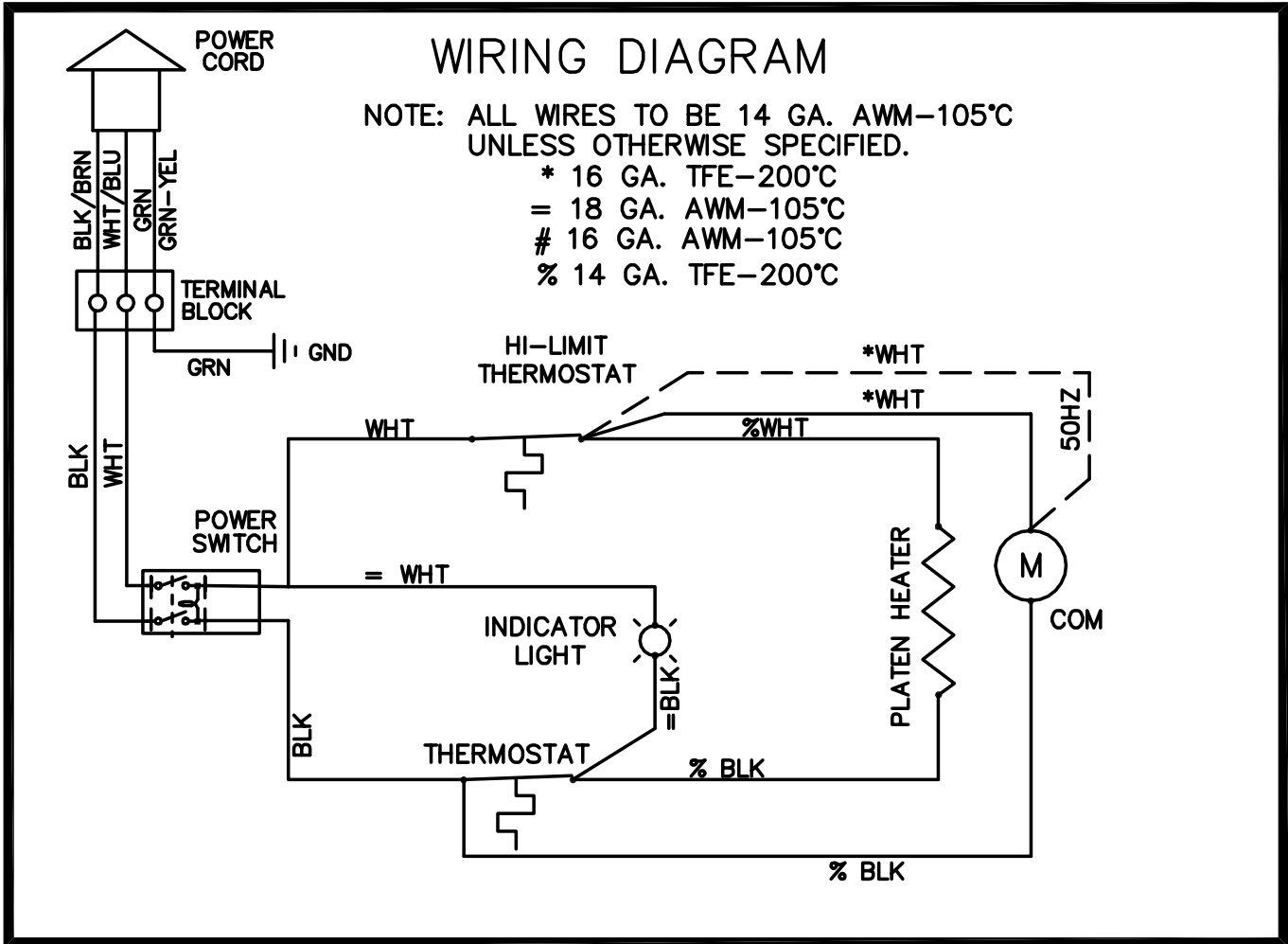

# Parts Identification

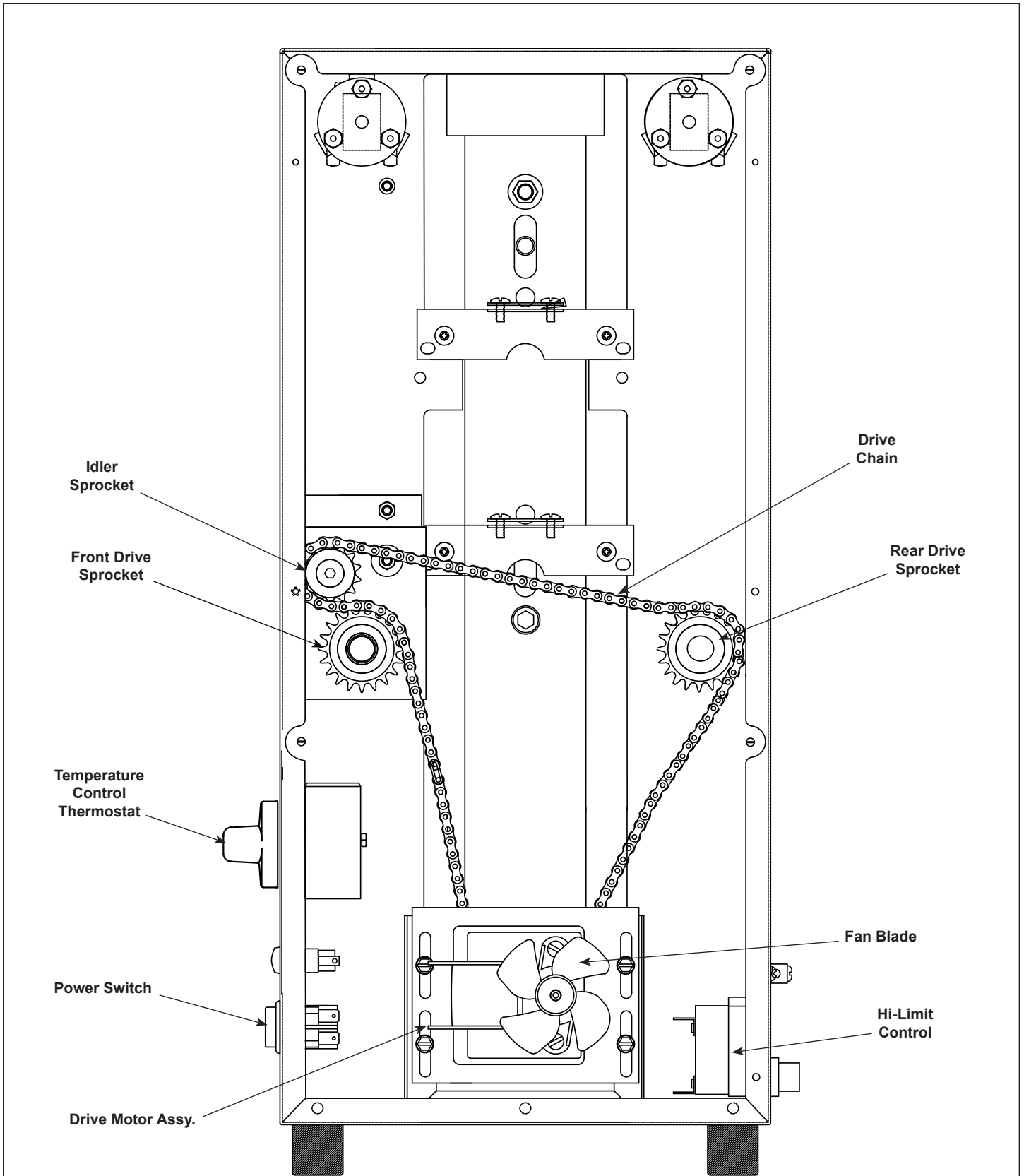

# Replacement Parts

## Parts List

(See Exploded Views for more information)

### NOTE:

Use only genuine Antunes replacement parts in this unit. Use of parts other than those supplied by the manufacturer will void the warranty.

Item No.	Part #	Description	Qty.
1	7001311	Conveyor Belt Kit	1
2	2150117	Idler Shaft	2
3	0011609	Conveyor Cover Assy. (Incl. #95)	2
4	0010475	Tensioner Assy.	4
5	0800406	Rod, Conveyor Cover	4
6	7000207	Sprocket (Incl. #65)	8
7	7000199*	Spacer Kit	2
8	0011444	Control Cover	1
9	2150118	Drive Shaft	2
10	0700463	Power Cord/Plug NEMA 5-15P	1
11	4030355	Thermostat, 600°F	1
12	7000296	Ball Bearing (Pack of 2)	1
13	0011310	Inner Spring Tensioner Assy (Incl. #96, 89, 90)	4
14	1031695	Spec Label	1
16	7000167	Bearing & Retainer Kit (Single Pack)	6
	7000224	Bearing & Retainer Kit (Pack of 6)	-
17	2150181	Drive Sprocket	2
18	2150187	Drive Chain	1
19	0011299	Idler Sprocket & Bearing	1
20	0011300	Bracket, Idler Sprocket (Incl. #50, 57, 61, 19, & 87)	1
21	0506946	Bracket, Motor Mounting	1
22	0011676	Drive Motor Assy, 120V/9RPM	1
23	2150199	Sprocket, Motor	2
24	4010245	Rocker Switch, On/Off	1
25	4060355	Terminal Block	1
26	0503495	Retainer, Tension Bracket, RH	2
27	0503507	Retainer, Tension Bracket, LH	2
28	4060323	Indicator Light, Amber (125V)	1
29	0013373	Roller Tensioner Assy.	2
30	0503496	Tensioner Bracket, Right	2
31	0503497	Tensioner Bracket, Left	2
32	1000899	Label, Control	1
33	10P1047*	Label, Dial (Pack of 10)	1
34	2100253	Knob, 1/4 Shaft	2
35	0503390	Cover, End Housing	1

Item No.	Part #	Description	Qty.
36	2100133	Knob, Thermostat Control	1
37	0021170	Weldment, End Housing	1
38	7000249	Release Sheet (Pack of 3)	-
	7000250	Release Sheet (Pack of 10)	-
39	0021194	Weldment, Control Housing	1
40	7000121	Slide Rail Kit (Incl. Two Slide Rails for Tensioners)	2
41	0021207	Conveyor Cam	2
42	7000176	Thermocouple Retainer Kit (Incl. #67, 76, 93)	2
43	4030332	High Limit Control	1
44	0400251	Strain Relief	1
45	0400138	Locknut, 1/2"	1
46	0503590	Plate, Motor Mounting	1
48	0503385	Bun Chute	1
50	331P101*	Nut, Hex, 5/16 x 18"	1
51	7000229	Platen, 120V	1
53	4060374	Ground Lug, Copper	1
57	0503608	Cover Plate	2
58	4000222	Motor, Gear 115V 9RPM	1
59	2100256	Tape, Hi-Temp	4
61	212P118*	Flat Washer, 5/16"	1
62	0500464	Retainer, Bearing	1
64	0012976	Heat Shield Assy.	1
65	325P163*	Setscrew, 1/4-28 x 5/16"	8
66	1001192	Label, Caution Hot	1
67	3080115	Screw, Mach #8-32 X 3/8 S/S Pan Head	9
68	306P104*	Screw, #6-32 x 1/4"	8
69	3020106	Rivet, Semi Tubular-3/16"	1
70	308P143*	Nut, #8-32, "KEPS"	6
71	310P103*	Screw, #10-32 x 1/4"	4
72	310P140*	Washer, #10	6
73	308P101*	Nut, #8-32	3
74	306P101*	Nut, Hex, #6-32	2
75	306P123*	Screw, #6-32 x 7/8"	2
76	0503444	Bracket, Thermocouple	2
77	100P900*	Label, Service	1
78	325P104*	Washer, 1/4"	4
79	325P109*	Screw, 1/4-20 x 1/2"	4
80	308P124*	Screw, 1-Way, #8-32 x 1/2"	1
81	210P230	Bumper, Recess Leg, 1"	4
82	310P136*	Screw, #10-32 x 1-1/4"	4
83	308P133*	Screw, #8-32 x 1/4"	12
85	308P181*	Screw, Flat Hd., #8-32 x 3/8"	4
86	218P145*	Cover, Leg, Bumper	4
87	331P103*	Shoulder Bolt, 5/16"-18	1
88	306P105*	Screw, #6-32 x 1/2"	1

<b>Item No.</b>	<b>Part #</b>	<b>Description</b>	<b>Qty.</b>
89	0503455	Tension Spring, Inner	4
90	2100378	Slide Rail	1
91	0011792	Bun Feeder Assy	1
93	0503446	Plate, T.Couple Bracket	1
* Only available in packages of 10.			

# Replacement Parts

## Exploded Diagram 1

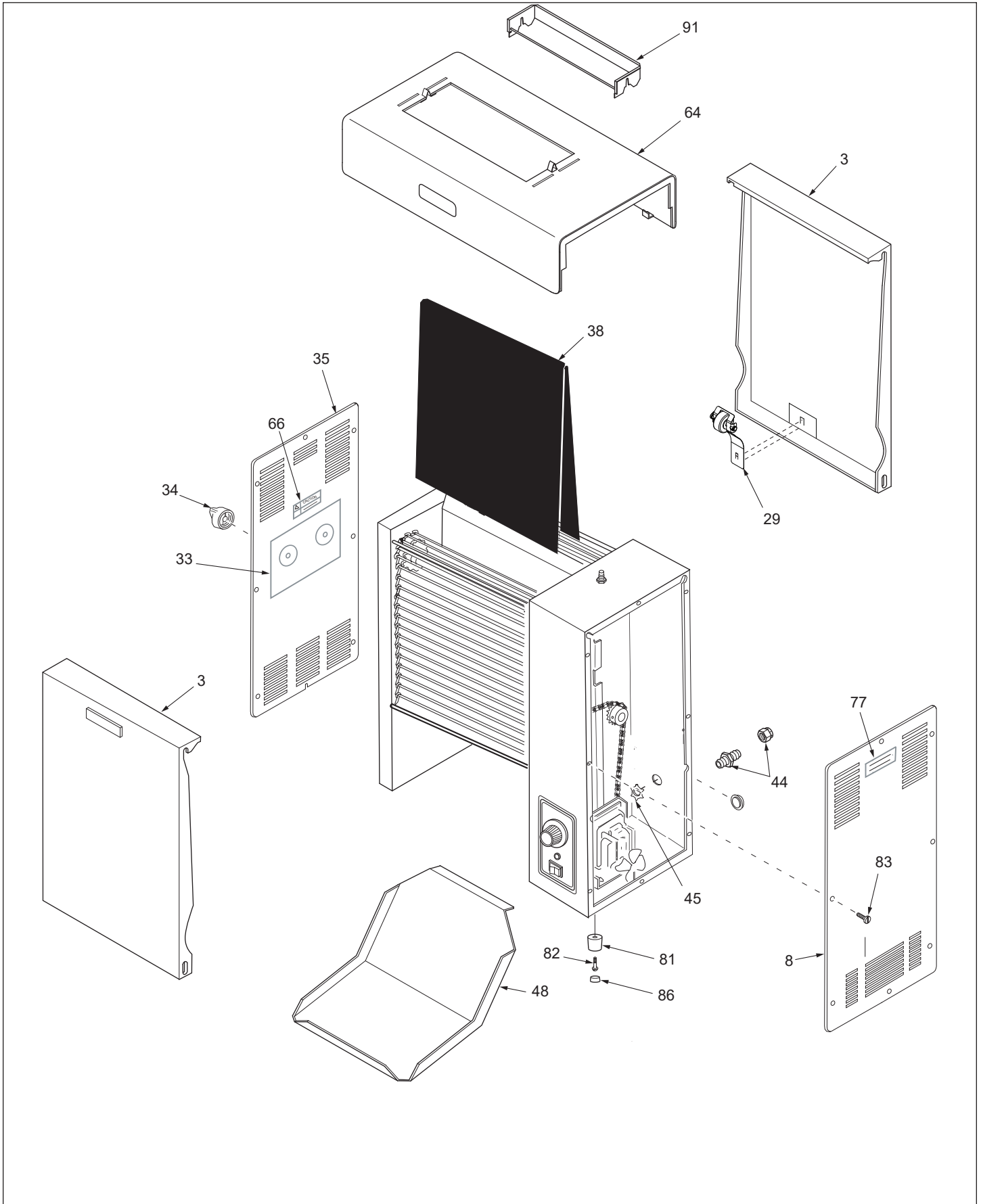



# Replacement Parts

## Exploded Diagram 2

**NOTE:** As of March 2017, the Interlock Switch is discontinued from use. If your toaster has the Interlock Switch and it fails, order kit 7001436 to remove and bypass the Interlock Switch.

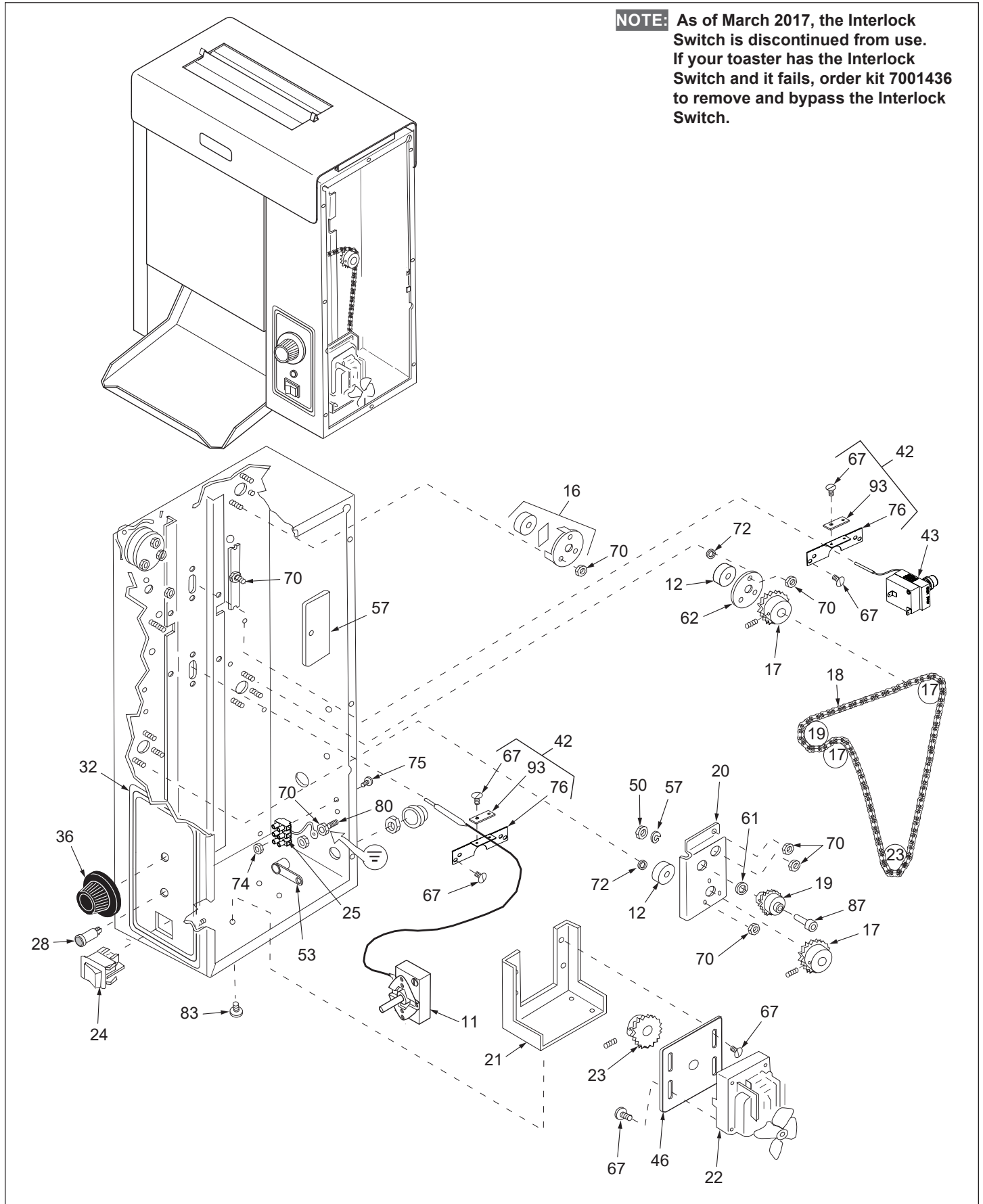



# Replacement Parts

## Optional Kits

### Mechanical Butter Wheel Kit (model 7000703)

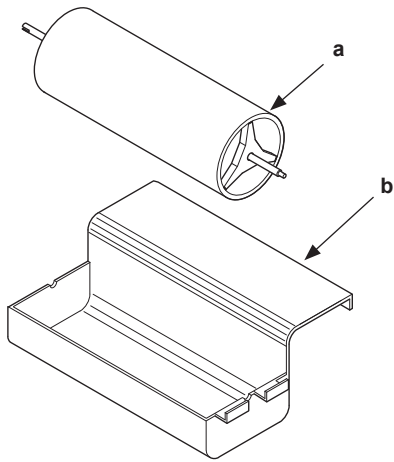

Item	Part #	Description	Qty.
1	7000703	Butter Wheel Kit (Includes Items Below)	-
a	0020205	Butter Roller Weldment	1
b	0021589	Butter Tray Weldment	1





## Limited Warranty

Equipment manufactured by Antunes has been constructed of the finest materials available and manufactured to high quality standards. These units are warranted to be free from electrical and mechanical defects for a period of one (1) year from date of purchase under normal use and service, and when installed in accordance with manufacturer's recommendations. To insure continued operation of the units, follow the maintenance procedures outlined in the Owner's Manual. During the first 12 months, electromechanical parts, non-overtime labor, and travel expenses up to 2 hours (100 miles/160 km), round trip from the nearest Authorized Service Center are covered.

This warranty does not cover cost of installation, defects caused by improper storage or handling prior to placing of the Equipment. This warranty does not cover overtime charges or work done by unauthorized service agencies or personnel. This warranty does not cover normal maintenance, calibration, or regular adjustments as specified in operating and maintenance instructions of this manual, and/or labor involved in moving adjacent objects to gain access to the equipment. This warranty does not cover consumable/wear items. This warranty does not cover damage to the Load Cell or Load Cell Assembly due to abuse, misuse, dropping of unit/shock loads or exceeding maximum weight capacity (4 lbs). This warranty does not cover water contamination problems such as foreign material in water lines or inside solenoid valves. It does not cover water pressure problems or failures resulting from improper/incorrect voltage supply. This warranty does not cover Travel Time & Mileage in excess of 2 hours (100 miles/160 km) round trip from the nearest authorized service agency.

Antunes reserves the right to make changes in design or add any improvements on any product. The right is always reserved to modify equipment because of factors beyond our control and government regulations. Changes to update equipment do not constitute a warranty charge.

If shipment is damaged in transit, the purchaser should make a claim directly upon the carrier. Careful inspection should be made of the shipment as soon as it arrives and visible damage should be noted upon the carrier's receipt. Damage should be reported to the carrier. This damage is not covered under this warranty.

Warranty charges do not include freight or foreign, excise, municipal or other sales or use taxes. All such freight and taxes are the responsibility of the purchaser.

This warranty is exclusive and is in lieu of all other warranties, expressed or implied, including any implied warranty or merchantability or fitness for a particular purpose, each of which is hereby expressly disclaimed. The remedies described above are exclusive and in no event shall Antunes be liable for special consequential or incidental damages for the breach or delay in performance of this warranty.

The warranty does not extend to:

- Damages caused in shipment or damage as result of improper use.
- Installation of electrical service.
- Installation, calibration, or adjustment.
- Normal maintenance outlined in this manual.
- Malfunction resulting from improper service or maintenance.
- Damage caused by improper installation, abuse, or careless handling.
- Damage from moisture getting into electrical components.
- Damage from tampering with, removal of, or changing any preset control or safety device.
- Damage caused by parts or components not provided by Antunes



**Corporate Headquarters**  
Carol Stream, IL, USA  
Phone: +1.630.784.1000  
Toll Free: +1.800.253.2991  
Fax: + 1.(630).784-1650

**China Facility**  
Suzhou, China  
Phone: +84.512.6841.3637  
Fax: +86.512.6841.3907

**India Facility**  
Chennai, India  
Phone: +91.44.25532212  
Fax: +91.44.25532415