

Place this manual in the Toaster section of your Equipment Manual.

Manufactured exclusively for
McDONALD'S®

BY

ANTUNES

180 KEHOE BLVD.
CAROL STREAM, ILLINOIS 60188, U.S.A.

PHONE: 1-630-784-1000

TOLL FREE: 1-877-392-7854

FAX: 1-630-784-1650

www.antunes.com



Antunes



SS-200 & SS-400

Scan with mobile device or enter URL
for product and service information.

<http://tiny.cc/ajaprodSS>



TABLE OF CONTENTS

Owner Information	2	Installing the Surface Steamer	6
General	2	Connecting a Water Pressure Regulator	6
Warranty Information	2	Operating Instructions	7
Service/Technical Assistance	2	Programming	8
Specifications	3	Programming the Surface Steamer	8
Dimensions	3	Maintenance	9
Electrical Ratings and Plug Configuration	3	Daily Cleaning	9
Important Safety Information	4	Quarterly Cleaning (or as needed)	10
Installation	5	Troubleshooting	11
Unpacking	5	Wiring Diagrams	14
Equipment Setup	6	Replacement Parts	15
		Notes	17

LIMITED WARRANTY

The Antunes Food Service Equipment Division of Antunes provides the following limited warranty to the original purchaser of all McDonald's Equipment. All components are warranted against defects in the material and workmanship for a period of two (2) years from date of original installation.

If any part becomes defective during period of this Warranty, Antunes will pay negotiated straight time labor costs to an Authorized Service Agent to replace the part, plus travel expenses up to 50 miles/80 km, 1 hour each way (100 miles/160 km, 2 hours round trip).

WARRANTY EXCLUSIONS

- The cost of Installation.
- Equipment that has been damaged due to shipment. Purchaser should make damage claim directly upon carrier.
- Alteration, misuse, abuse.
- Improper storage or handling.
- Improper maintenance.
- Failure to follow proper Installation instructions, including electrical connection.
- Improper or unauthorized repairs.
- Scheduled Maintenance procedures as outlined in your MRC Card.
- This Warranty does not cover Consumable items.
- Water pressure problems or contamination problems such as foreign material in water lines or inside solenoid valves due to an incoming water source.
- Overtime or Holiday charges.
- Mileage over 50 miles/80 km (100 miles/160 km round-trip), or travel time over two (2) hours.
- Freight, foreign, excise, municipal or other sales or use taxes.
- Consequential damages such as loss of profit, loss of time, the cost of repairing or replacing other property which is damaged, or any other incidental damage of any kind.

Antunes reserves the right to make changes in design or add improvements on any products. The right is always reserved to modify Equipment because of factors beyond our control and government regulation. Changes to Equipment do not constitute a warranty charge.

This warranty is exclusive and is in lieu of all other warranties, expressed or implied, including any implied warranty of merchantability or fitness for a particular purpose, each of which is expressly disclaimed. The remedies described above are exclusive, and in no event shall Antunes or any of its Divisions be liable for special consequential or incidental damages for the breach or delay in the performance of this warranty.

This manual is for the exclusive use of licensees and employees of McDonald's Systems, Inc.
© McDonald's Corporation All Rights Reserved

SURFACE STEAMER SS-200TT

OWNER INFORMATION

General

This manual is produced for the Surface Steamer.

The Surface Steamer is designed for the quick steaming and heating of buns. This design allows the operator to place buns on both sides of Surface Steamer at the same time. Water is superheated into steam, which penetrates the bun to heat it quickly and efficiently.

This manual provides the safety, installation, and operating procedures for the Surface Steamer. We recommend that this manual be read prior to installing and operating the unit.

The Surface Steamer is manufactured from the finest materials available and is assembled to Antunes's strict quality standards. This unit has been tested at the factory to ensure dependable trouble-free operation.

Warranty Information

Please read the full text of the Limited Warranty in this manual. If the unit arrives damaged, contact the carrier immediately and file a damage claim with them. Save all packing materials when filing a claim. Freight damage claims are the responsibility of the purchaser and are not covered under warranty.

SERVICE/TECHNICAL ASSISTANCE

If you experience any problems with the installation or operation of your unit, contact A.J. Antunes & Co. Technical Support at 1-877-392-7854.

Fill in the information below and have it handy when calling your Authorized Service Agency for assistance. The serial number is on the specification plate located on the side of the unit.

Purchased From: _____

Date of Purchase: _____

Model No.: _____

Serial No.: _____

Mfg. No.: _____

Refer to the service agency directory packaged with your manual and fill in the information below:

Authorized Service Agency

Name: _____

Phone No.: _____

Address: _____

Use only genuine Antunes replacement parts in this unit. Use of replacement parts other than those supplied by the manufacturer will void the warranty. Your Authorized Service Agency has been factory trained and has a complete supply of parts for this toaster.

You may also contact the factory at 1-877-392-7854 (North America only), or 630-784-1000 if you have trouble locating your local Authorized Service Agency.

To locate your nearest International Authorized Service Agency: log onto the McDonald's web site: www.mcdonalds.com and follow the on-screen directions.

WARNING

ELECTRICAL SHOCK HAZARD. FAILURE TO FOLLOW THE INSTRUCTIONS IN THIS MANUAL COULD RESULT IN SERIOUS INJURY OR DEATH.

- Electrical ground is required on this appliance.
- Do NOT modify the power supply cord plug. If it does not fit the outlet, have a proper outlet installed by a qualified electrician.
- Do NOT use an extension cord with this unit.
- Check with a qualified electrician if you are unsure if the appliance is properly grounded.

CAUTION

All electrical connections must be in accordance with local electrical codes and any other applicable codes.

IMPORTANT! Keep these instructions for future reference. If the unit changes ownership, be sure this manual accompanies the equipment.

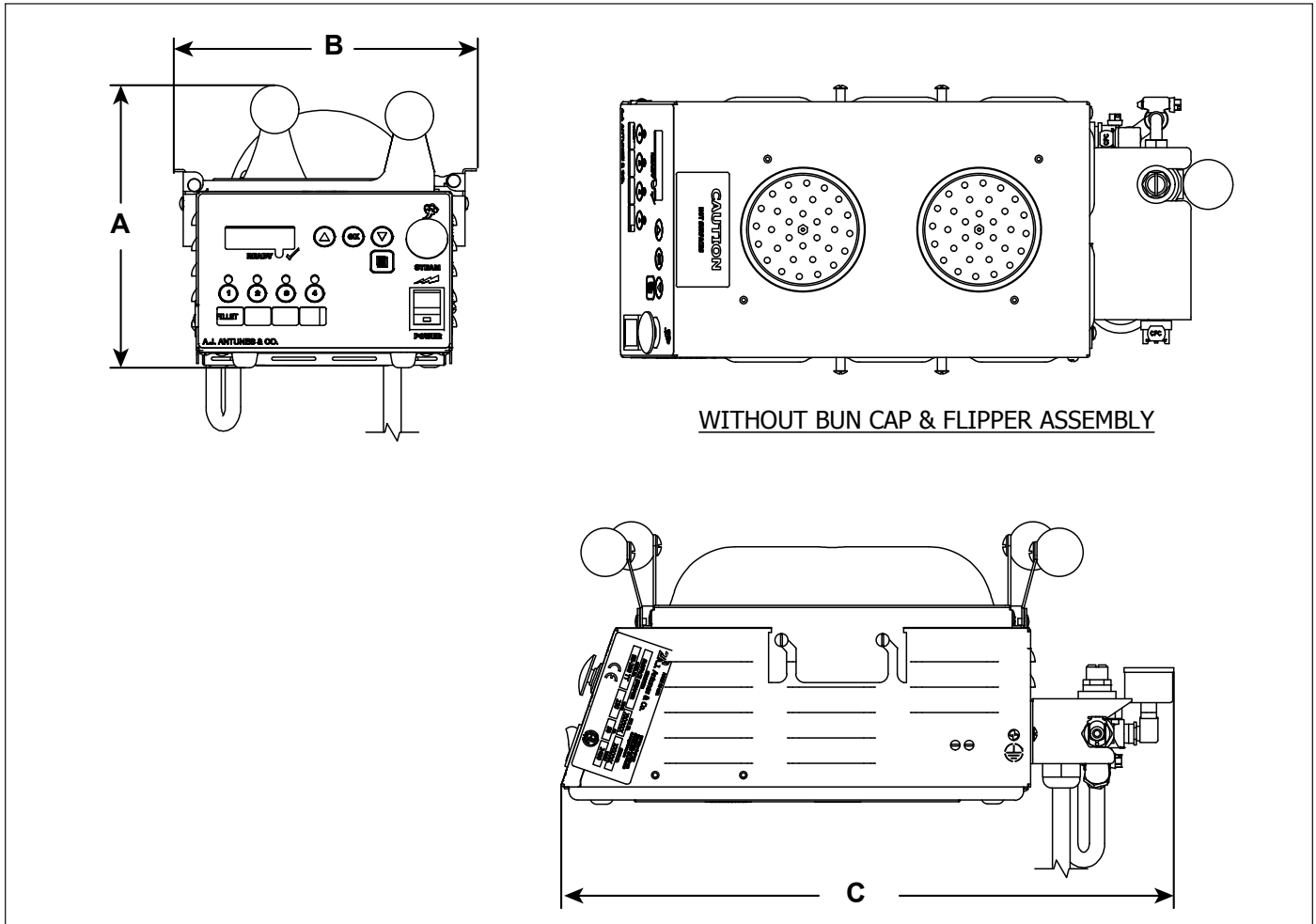

SPECIFICATIONS

Dimensions

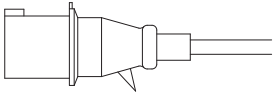

Model & Mfg. No.	Width (A)	Depth (B)	Height (C)
SS-200TT 9100907 & 9100908	8" (203 mm)	7 1/4" (184 mm)	17 3/8" (441 mm)

Electrical Ratings and Plug Configuration

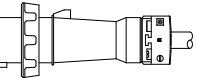
Model & Mfg. No.	Volt	Watts	Amps	Hz	Plug Description	Plug Configuration
SS-200TT 9100907	230	2400	10.4	50/60	IEC-309, 16 Amp., 250 Volt Pin & Sleeve (Assembly only) P/N 0700437	 
SS-200TT 9100908	208	2400	10.4	50/60	20 Amp. Pin & Sleeve	 

IMPORTANT SAFETY INFORMATION

Throughout this manual, you will find the following safety words and symbols that signify important safety issues with regards to operating or maintaining the equipment.

WARNING

GENERAL WARNING. Indicates information important to the proper operation of the equipment. Failure to observe may result in damage to the equipment and/or severe bodily injury or death.

WARNING

ELECTRICAL WARNING. Indicates information relating to possible shock hazard. Failure to observe may result in damage to the equipment and/or severe bodily injury or death.

CAUTION

GENERAL CAUTION. Indicates information important to the proper operation of the equipment. Failure to observe may result in damage to the equipment.

WARNING

HOT SURFACE WARNING. Indicates information important to the handling of equipment and parts. Failure to observe may result in personal injury.

In addition to the warnings and cautions in this manual, use the following guidelines for safe operation of the unit:

- Read all instructions before using equipment.
- For your safety, the equipment is furnished with a properly grounded cord connector. Do NOT attempt to defeat the grounded connector.
- Install or locate the equipment only for its intended use as described in this manual. Do NOT use corrosive chemicals in this equipment.
- Do NOT operate this equipment if it has a damaged cord or plug, if it is not working properly, or if it has been damaged or dropped.
- This equipment should be serviced by qualified personnel only. Contact the nearest Authorized Service Agency for adjustment or repair.
- Do NOT block or cover any openings on the unit.
- Do NOT immerse cord or plug in water.
- Keep cord away from heated surfaces.
- Do NOT allow cord to hang over edge of table or counter.
- Do NOT clean the unit with a water jet.
- Do NOT submerge the unit in SolidSense Sanitizer or water.

The following warnings and cautions appear throughout this manual and should be carefully observed.

- Turn the power off, disconnect the power source, and allow unit to cool down before performing any service or maintenance.
- The procedures in this chapter may include the use of chemical products. These chemical products will be highlighted with bold face letters followed by the abbreviated **HCS** (Hazard Communication Standard). See Hazard Communication Standard manual for the appropriate Material Safety Data Sheets (MSDS).
- The equipment should be grounded according to local electrical codes to prevent the possibility of electrical shock. It requires a grounded receptacle with separate electrical lines, protected by fuses or circuit breaker of the proper rating.

CAUTION

All electrical connections must be in accordance with local electrical codes and any other applicable codes.

This appliance is not intended for use by persons (including children) with reduced physical, sensory or mental capabilities, or lack of experience and knowledge, unless they have been given supervision or instruction concerning use of the appliance by a person responsible for their safety.

Children should be supervised to ensure that they do not play with the appliance.

INSTALLATION

Unpacking

1. Remove unit and all packing materials from shipping carton. The main carton should contain:
 - Surface Steamer unit (Figure 1)
 - Water Regulator
2. Remove all packing materials and protective coverings from the unit and parts.

NOTE: If any parts are missing or damaged, contact Antunes Technical Service IMMEDIATELY at 1-877-392-7854 (North America only), or 630-784-1000.

3. Remove and wash the Steamer Mesh Covering at the three compartment sink, and allow the unit to air dry.
4. Wipe down the unit with a clean damp cloth and allow to air dry.
5. Re-install the Steamer Mesh Covering.

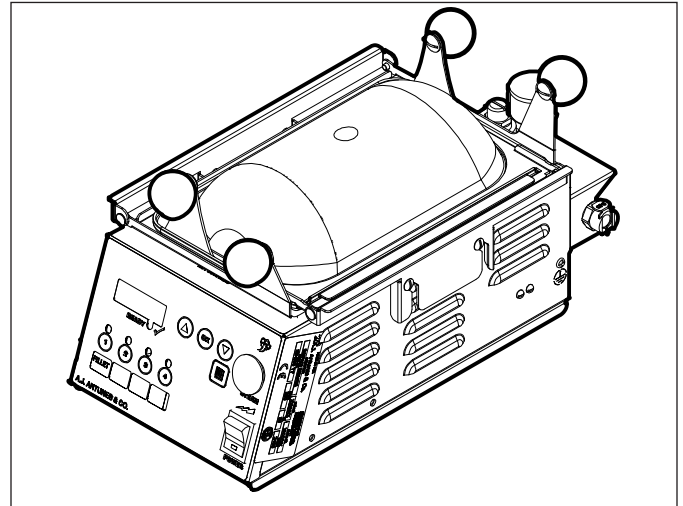

Figure 1. SS-200TT Surface Steamer

⚠ CAUTION ⚠

This equipment is to be installed to comply with the basic plumbing code of the Building Officials and Code Administrators, Inc. (BOCA) and the Food Service Sanitation Manual of the Food and Drug Administration (FDA).

⚠ WARNING ⚠

For a replacement power cord, use manufacturer-supplied Type Y attachment with specially prepared cord. It must be replaced by the manufacturer, its service agent, or a similarly qualified person in order to avoid a hazard.

⚠ CAUTION ⚠

All electrical connections must be in accordance with local electrical codes and any other applicable codes.

SURFACE STEAMER SS-200TT

INSTALLATION (continued)

Equipment Setup

When placing the steamer into service, pay attention to the following guidelines.

- Make sure power is off and the unit is at room temperature.
- Do NOT block or cover any openings on the unit.
- Do NOT immerse the cord or plug in water.
- Keep the cord away from heated surfaces.
- Do NOT allow the cord to hang over edge of table or counter.

Installing the Surface Steamer

1. Be sure to place the Surface Steamer onto the Prep Surface so that the Bun Cap and Flipper open in the direction of food prep flow.
2. Ensure that the line voltage corresponds to the stated voltage on the unit's specification label and power cord warning tag.
3. Plug the power cord into the appropriate outlet.

NOTE: Route the power cord in a safe manner so that it is out of the way. Ensure the power cord is away from the housing to prevent damage.

Connecting a Water Pressure Regulator

The Surface Steamer requires the use of a Water Pressure Regulator (included) set to 10 PSI. Follow these steps to install the Water Pressure Regulator.

NOTE: Incoming water is controlled by a normally closed (NC) solenoid valve located inside the Steamer's electrical housing.

1. Turn off the water valve (not supplied) that supplies water to the unit.
2. Connect the water source to the Quick Disconnect closest to the regulator.
3. Turn the water valve on.
4. Hold the other Quick Disconnect over a bucket, then press and hold the white plastic tip until there's a good, steady water flow. This purges all air out of the line.
5. Release the plastic tip and check the pressure on the Water Pressure Regulator. It should read 10 PSI.
 - a.) If it reads less, increase the water pressure by loosening the locknut and turning the knob clockwise.
 - b.) If it reads more, decrease the water pressure by loosening the locknut and turning the knob counter clockwise.

NOTE: When adjusting the knob, you must relieve the existing pressure by pressing the white plastic tip on the Quick Disconnect Insert for 3 seconds. The Water Pressure Regulator will then show the new pressure.

6. Once the regulator reads 10 PSI, secure the locknut to lock it in place.
7. Push the Quick Disconnect Insert into the fitting on the unit it clicks.

⚠ CAUTION ⚠

Inlet water line pressure should be between 20 PSI (137 kPa) and 35 PSI (241 kPa). The water pressure regulator must be set to 10 PSI (69 kPa). Higher water pressure may cause poor performance or flooding. It is recommended to use Reverse Osmosis water for better performance of unit and reduced PM.

⚠ CAUTION ⚠

Do NOT re-use old hose sets with the SS-200. Only use new hose sets with the unit.

OPERATION

Operating Instructions

1. Turn the power on and allow the unit to heat up.

NOTE: The display indicates “LO” until the preset operating temperature is reached. Once the unit is heated up, the unit displays the cycle time.

2. When the unit is ready, select the desired steam channel by pressing the appropriate button for that channel.
3. Open the Bun Cap and place the heel and crown cut side down onto Flipper. Close the Bun Cap.
4. Press the **Activation** button to begin a steam cycle. The display counts down to zero and an audio sound signals the end of the cycle.

NOTE: A new cycle cannot be started until the audio signal is finished. To adjust the number of repetitions of the audio signal, see the Programming section of this manual.

4. Open the Bun Cap and then lift the Flipper to remove the buns from the steam area.
5. Complete the assembly of the sandwich.

⚠ CAUTION ⚠
Buns will be hot after steaming! Lift the Flipper to remove buns. Use caution to avoid burns.

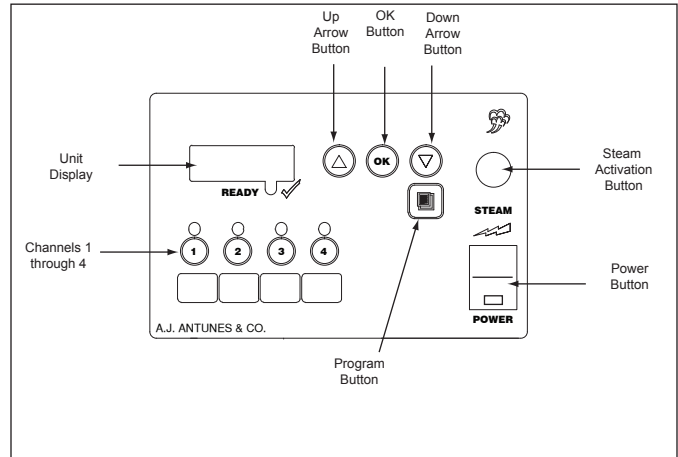

Figure 2. Primary Control Panel View

NOTE: The steamer returns to the default program channel of #1 (See Figure 3) after completing a steam cycle. For example, If you run a steam cycle on channel 4, the steamer returns to channel 1 once the steam cycle completes.

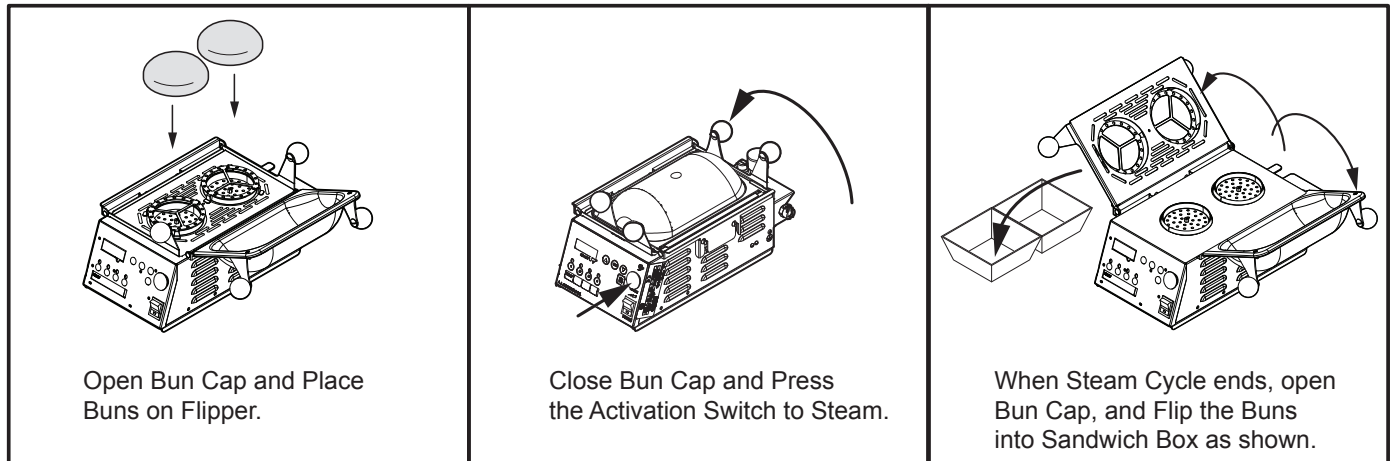

Figure 3. Steaming Buns

PROGRAMMING

Programming the Surface Steamer

1. Press and hold the **PROGRAM** button until “**CYC**” appears on the display (Figure 5) then release the **Program** button.
2. Press the **OK** button. The unit displays the currently programmed cycle time.
3. Press the **UP** or **DOWN** arrow buttons to increase or decrease the cycle time in one second increments (from 1 to 60). Release all buttons at the desired setting. Then press the **PROGRAM** button to save changes.

NOTE: To save Programming changes, be sure to press the **PROGRAM** button (Figure 5) as soon as changes are made.

NOTE: During programming mode, the display returns to operation mode after 5 seconds of inactivity.

4. To program values listed in Table 1, repeat Step 1 but press **UP** until the desired value is displayed. Then press **OK** and use the **UP** or **DOWN** arrows to adjust. Press the **PROGRAM** button to save changes, press the **UP** or **DOWN** arrow buttons to move to the next value (Table 1).

Table 1 describes programmable features and parameters of the Surface Steamer: All four steam channels are programmed to these default values at the factory.

Default Values

Value	Description	Defaults
CYC	Length of the steam cycle in seconds. Available ranges are from 1 to .60 seconds adjustable in 1 second increments.	12 seconds
SHOT	Regulates the amount of water volume injected at each solenoid valve opening. A higher value equals more water; a lower value equals less water. Available ranges are .05 to 1.00 seconds adjustable in .05 second increments.	0.20
Intr	Interval - Time between injections of water. Available ranges are 0 to 10 seconds in increments of 1 second.	4
SETP	Setpoint temperature of the unit. Available ranges are 350 F (176°C) to 400°F (204°C). Increments: 1	400
RPT	Repeat - Number of times the audio signal repeats at the conclusion of a steam cycle (1 to 255). Increments: 1	2
DEGF/DEGC	Allows the user to select whether the unit displays temperatures in degrees Fahrenheit or Celsius.	DEG F

Table 1. Programmable Features

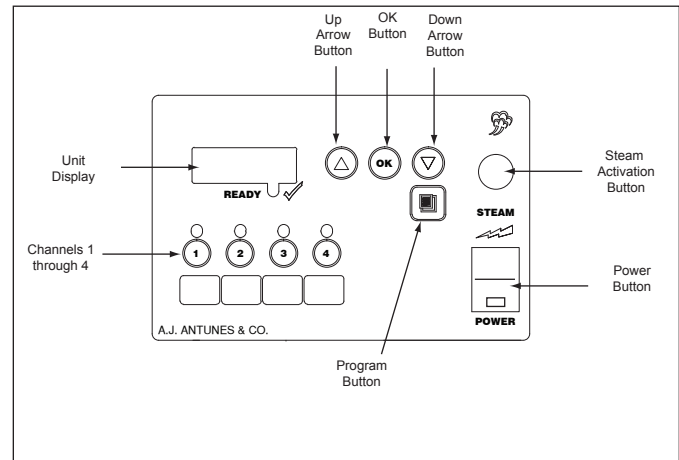

Figure 4. Primary Control Panel View

Factory Resets

Follow these steps to restore the system to the factory preset setting

1. Turn the power switch **OFF**.
2. Press and hold the **UP** and **DOWN** arrow buttons simultaneously and turn the power switch **ON**.
3. Do not release the buttons until after 3 seconds.

Generator Temperature

To view the actual temperature for the front generators, press and hold the **UP** arrow button.

To view the actual temperature for the rear generators, press and hold the **DOWN** arrow button.

MAINTENANCE
⚠ WARNING ⚠

Turn the power off, unplug the power cord, and allow the unit to cool down before performing any service or maintenance.

Daily Cleaning

1. **Turn off unit.** Turn the steamer's power switch to the off position. Unplug the power cord from the outlet. Allow the unit to cool down for 30 minutes.

NOTE: Daily Cleaning should be performed after close or during the breakfast menu (for 24-hour stores).

2. **Clean the Bun Caps.** Open the Bun Caps. Clean both sides of the Bun Caps with a clean, sanitized towel sprayed with EXCEED. Wipe the Bun Caps with a clean, sanitized towel sprayed with SolidSense Sanitizer Solution.

NOTE: Do NOT use no-scratch pads or steamer brushes on plastic parts.

3. **Clean the Flipper.** Open the Flipper. Clean both sides of the Flipper with a clean, sanitized towel sprayed with EXCEED. Wipe the Flipper with a clean, sanitized towel sprayed with SolidSense Sanitizer solution. If required, use a no-scratch pad to clean the flipper.
4. **Remove and clean the steamer Heat Shield Pad.** Remove the steamer Heat Shield Pad. Clean one side of the pad with a clean, sanitized towel sprayed with EXCEED. Next, wipe the steamer Heat Shield Pad with a clean sanitized towel sprayed with SolidSense Sanitizer. Repeat this step on the other side of the steamer Heat Shield Pad.

⚠ CAUTION ⚠

Clean the Steam Generators with a damp paper towel only. Do NOT use oily or dirty towels,

5. **Clean the Steam Generators and Diffusers.** Put on neoprene gloves. Remove the diffusers. Clean the Steam Generators with a paper towel dampened with water. Make sure all crumbs and seeds are removed from the generators. Clean the diffusers with a clean, sanitized towel sprayed with EXCEED. Wipe the diffusers with a clean, sanitized towel sprayed with SolidSense Sanitizer.

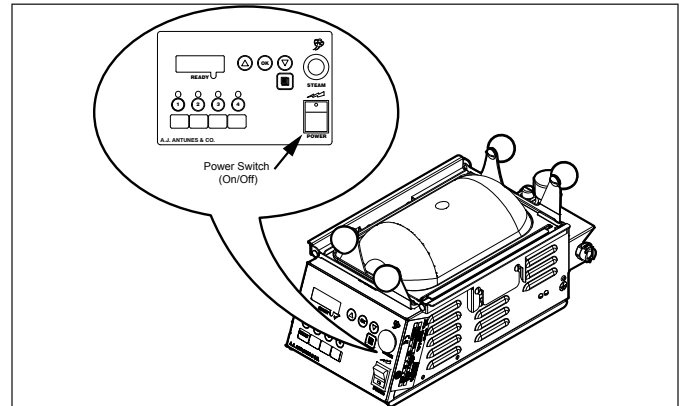

Figure 5. Control Panel and Power Switch

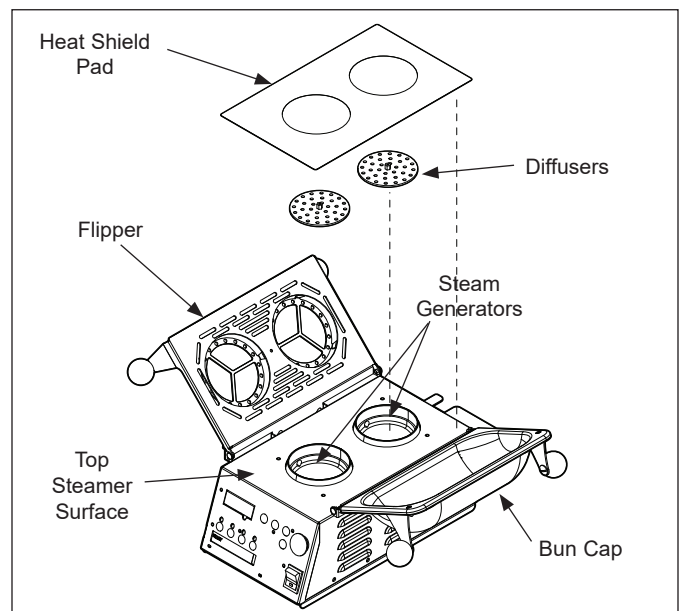

Figure 6. Cleaning the Steamer

6. **Clean the top steamer surface.** Wipe the top steamer surface with a clean, sanitized towel sprayed with EXCEED. Wipe the top steamer surface with a clean, sanitized towel sprayed with SolidSense Sanitizer.
7. **Clean outside of steamer.** Wipe the entire outside of the steamer with a clean, sanitized towel sprayed with EXCEED. Wipe the entire outside of the steamer with a clean, sanitized towel sprayed with SolidSense Sanitizer.
8. **Install the steamer Heat Shield Pad and Diffusers.** Place the steamer Heat Shield Pad on top of the steamer, reversing sides. Place the Diffusers into the Steam Generators.
9. **Close the Flipper and Bun Caps.** Close the Flipper and Bun Caps.

MAINTENANCE (continued)

QUICK RECOVERY FOR POOR STEAM OUTPUT

The SS-200 uses an open Heat/Steam Generator. Water sprayed onto the Generator surface flashes into steam immediately, but the minerals in the water stay on the Generator surface. A small amount of mineral deposits are needed for proper operation, but excessive deposits cause poor steaming efficiency and excessive moisture, which eventually hinders the steam action.

If the unit is not steaming correctly, follow this procedure to improve steaming quality.

1. Pour 59 ml (2 ounces) of tap water into a clean beverage cup.
2. Pour the water into both Steam Generators and let it boil off.

NOTE: If needed, repeat steps 1 and 2 a few times.

This should result in a fine covering of minerals on the steam generator.

Quarterly Cleaning (or as needed)

Check the steamer each quarter to ensure the generators are properly seasoned and the unit is operating correctly. Over time, product spills may hinder steaming. Follow these steps to ensure the steamer is working properly.

1. **Check for proper operation.** Turn the unit on and let it warm up. Steam 2 or 4 buns. If the unit steams the buns correctly, you do not need to continue. If the buns are not steamed correctly, continue with this procedure.
2. **Turn off unit.** Turn the steamer's power switch to the off position. Unplug the power cord from the outlet. Allow the steamer to cool for at least 30 minutes.
3. **Open the Bun Caps, Flipper, and remove the steamer Heat Shield Pad.** Open the Bun Caps and Flipper. Remove the Steamer Heat Shield Pad. Replace the Heat Shield Pad if torn.
4. **Wipe down the steam generators.** Put on neoprene gloves. Remove the diffusers. Wipe the Steam Generators with a paper towel dampened with water. Be sure to remove all crumbs and seeds from the steam Generator.
5. **Turn the unit on.** Plug the power cord into the outlet. Turn the unit on and let it warm up.
6. **Season the Steam Generators if too Silver.** Fill a clean beverage cup or any clean container with tap water. Put on neoprene gloves carefully pour a small amount of the water into the steam generators. Allow the water to boil off. Do not press any buttons. Repeat this step as needed.

NOTE: The water heats up quickly as it boils off. Use caution.

7. **Test the unit.** Press the activation button to run a steam cycle. If the unit does not steam correctly, repeat steps 6 and 7. If the unit still does not steam correctly, contact your Authorized Service Agency. Turn the unit off when there is no more water in the Steam Generators.
8. **Turn off unit.** Turn the unit off when there is no more water in the steam generators.

NOTE: Once seasoned, the steam generators will have a thin covering of minerals. This is required for proper steaming.

9. **Wipe down the unit.** Put on neoprene gloves. Wipe down the top steam surface and entire exterior of the unit with a clean towel sanitized with an egg,
10. **Install the steamer Heat Shield Pad and Diffusers.** Place the steamer Heat Shield Pad on the top of the steamer, reversing sides. Place the diffusers in the generators.
11. **Close the Flipper and Bun Caps.** Close the Flipper and Bun Caps.

CLEANING THE WATER INLET TUBE(S)

Follow this procedure as needed if the Water Inlet Tubes become clogged.

1. With the unit cool, insert a straightened paper clip into the Water Inlet Tube opening no more than 1 1/2 inches deep (Figure 7).
2. Turn the unit on and allow it to warm up.
3. Run two or three steam cycles to force out any obstructions from the tube.
4. Repeat steps 1 through 3 as needed.

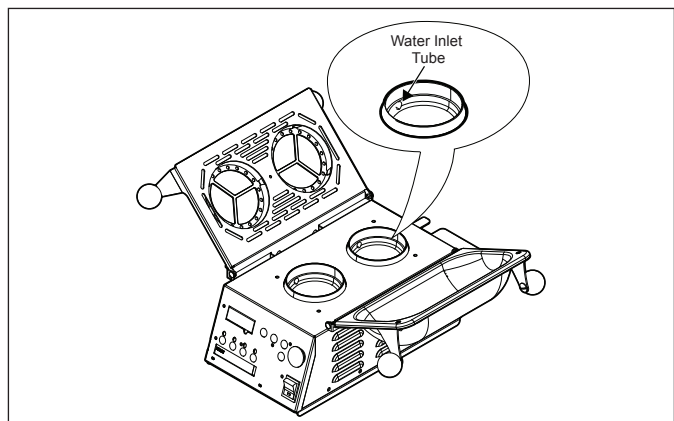

Figure 7. Water Inlet Tube

TROUBLESHOOTING

⚠WARNING⚠

To avoid possible personal injury and/or damage to the unit, inspection, test and repair of electrical equipment should be performed by qualified service personnel. The unit should be unplugged when servicing, except when electrical tests are required.

If the troubleshooting steps listed do not solve your machine problem, contact a Antunes Authorized Service Agency for further assistance or service.

Problem	Possible Cause	Corrective Action
Control Display is blank (Power Switch is in the On position but indicator light is off).	The power cord is not correctly plugged in.	Plug the power cord into the appropriate outlet.
	The power cord and/or electrical plug is damaged.	Inspect electrical wire, plug, and receptacle.
	The main electrical panel circuit breaker is off or is tripped.	Reset circuit breaker. Contact your maintenance person or Authorized Service Agency if it trips again.
	Power Switch is inoperable.	Contact your maintenance person or Authorized Service Agency for service.
Unit does not heat up (Power Switch is in the On position and the indicator light is on).	Hi-Limit Thermostat is tripped or inoperable.	Contact your maintenance person or Authorized Service Agency for service.
	Solid State Relay is inoperable.	
	Thermocouple is inoperable.	
	Main Control Board is inoperable.	
	Steam Generator is inoperable.	
Main electrical panel circuit breakers trips.	Damaged receptacle, plug, or cord or a loose connection or an internal component failure.	Contact your maintenance person or Authorized Service Agency if the condition repeats.
	Circuit breaker is overloaded.	
Water leaking inside electrical housing.	Pinhole leak in rubber hoses.	Replace hoses.
	Loose or damaged water line tubes and/or fittings inside electrical housing.	Tighten or replace tubes and/or fittings.
Water leaking at Water Pressure Regulator.	The O-rings are damaged.	Replace O-ring.
"Hi" appears on the display.	If this occurs during heavy use, the unit is not getting enough water pressure.	Check and adjust the water pressure regulator to 10 psi and adjust and reprogram values back to factory settings. See "Factory Resets."
	Pinched/kinked internal water lines or clogged injection tube.	Check for kinked water lines and clogs.
	Inoperable Solid State Relay.	Contact your maintenance person or Authorized Service Agency for service.
	Inoperable Main Control Board.	

TROUBLESHOOTING (continued)

Problem	Possible Cause	Corrective Action
Unit heats but there is little or no steam produced and/or The product requires more steaming than usual.	Water Line Valve is closed.	Check that the Water Line Valve is open.
	Water injection tube is restricted.	Check and clean the Injection Tube as described in the Maintenance section of this manual.
	Quick Disconnect Fittings are not fully engaged at the Water Pressure Regulator.	Remove and re-engage the Quick Disconnect Fittings firmly until it clicks into place. Replace if damaged.
	Low or no water pressure in the water line.	If pressure is low, contact your maintenance person or plumber. Check incoming water line for water pressure.
	Improper water pressure to unit.	Verify that a Water Pressure Regulator is installed and set to 10 psi.
	Unit is not being cleaned properly (daily/monthly).	Clean the unit daily and monthly as described in the Maintenance section of this manual.
	Programming and/or SHOT , Intr values were adjusted/changed improperly.	Reprogram the SHOT and Intr values as described in the Programming section of this manual. See "Factory Resets."
	Insufficient or excessive calcium/mineral deposits on the Generator surface.	Verify that a thin layer of calcium/mineral deposits is present on the Generator surface. Refer to the Maintenance section of this manual.
	Generator surface is bare (little or no traces of mineral deposits).	The Generator surface must have a thin coating of calcium/mineral deposits for proper steaming. Refer to the Maintenance section of this manual.
	The internal rubber hoses are pinched or kinked.	Straighten and reposition the rubber hoses.
	Generator Diffusers are missing.	Install Generator Diffuser or replace if missing.
Generator surface temperature is too low.	Verify that the Generator set point temperature is 400°F (204°C). See "Factory resets."	
"Lo" appears on the display during operation.	Water Pressure is too high and/or out of range.	Adjust the water pressure to 10 psi and reprogram values back to factory settings.
	Normal for several minutes during heat up period.	Wait 10 minutes. If Lo is still displayed, adjust the water pressure to 10 psi and reprogram values back to factory settings. See "Factory Resets." If Lo is still displayed, contact your maintenance person or Authorized Service Agency for service.
"HOT" appears on the display during operation.	The temperature inside the electrical compartment is above 160°F (71°C).	Make sure there is enough air flow around the unit. Relocate the unit if necessary.
		Verify that the Insulation and Heat Shield are installed correctly around the heat/steam generators (items 22 and 15 in the "Replacement Parts" section).
"OPEN" appears on the display during operation.	The front and/or rear thermocouple is disconnected or open.	Contact your maintenance person or Authorized Service Agency if the condition repeats.
	Faulty main Control Board.	

TROUBLESHOOTING (continued)

Problem	Possible Cause	Corrective Action
Excessive condensation in Food Compartment.	Water pressure is too high.	Verify that the Water Pressure Regulator is set to 10 psi. Adjust accordingly.
	Programming and or SHOT and Intr values were adjusted improperly (Timer Models only).	Reprogram the SHO and H2O values as described in the Programming section of this manual to factory settings. See "Factory Resets."
Excessive Steam escapes from front or sides of steamer.	Worn or damaged Bun Caps.	Replace Bun Caps.
Steam Generator's surface becomes flooded (fills with excess water).	Water Pressure Regulator is faulty or not properly installed.	Verify that a Water Pressure Regulator is installed and set to 10 psi. Adjust accordingly or replace.
	Programming and/or the SHO value was adjusted or changed improperly.	Reprogram the Control Board to the recommended settings. Refer to the Programming section of this manual. See "Factory Resets."
	Solenoid Valve is leaking due to debris trapped inside the plunger.	Attempt to flush the debris out of the valve by operating the unit on a number of cycles and then letting it rest. If the unit still leaks, disassemble the Solenoid Valve and clean out the plunger. Reassemble the unit and test again. If a leak is still present, replace the Solenoid Valves. Contact your maintenance person or Authorized Service Agency.
	Improper Daily/Monthly cleaning.	Follow the Daily/Monthly cleaning procedures carefully.
	The Generator surface temperature is too low.	Verify that the Generator set point temperature is between 400°F (204° C). See "Factory Resets."
	Insufficient or excessive calcium/mineral deposits on the Generator surface.	Verify that a thin layer of calcium/mineral deposits is present on the Generator surface. Refer to the Maintenance section of this manual.
	Solenoid Valve is installed incorrectly.	If the Solenoid Valve was replaced, verify that the "IN" and "OUT" labels on the valve correspond to the water flow.

SURFACE STEAMER SS-200TT

WIRING DIAGRAMS

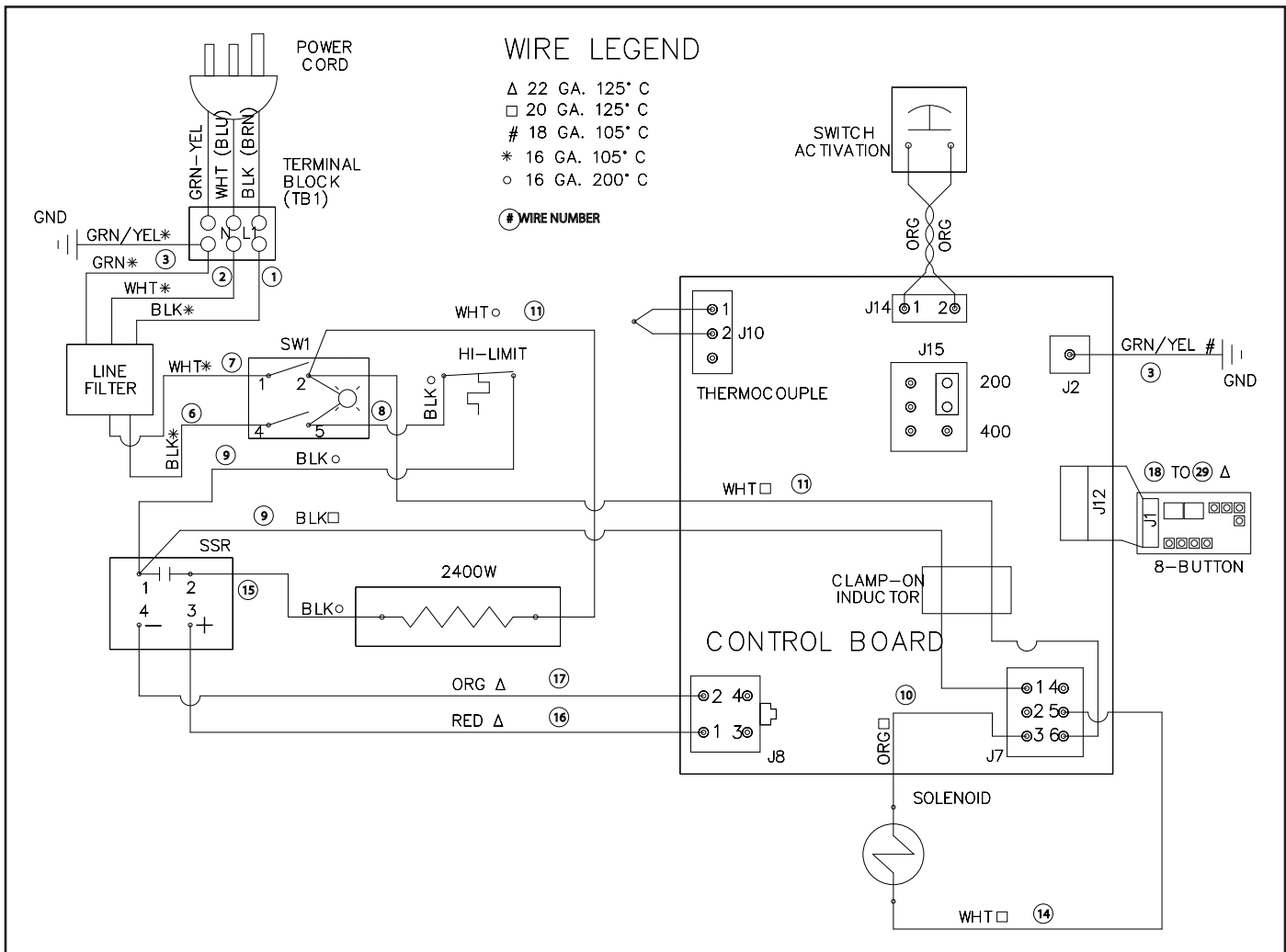

REPLACEMENT PARTS

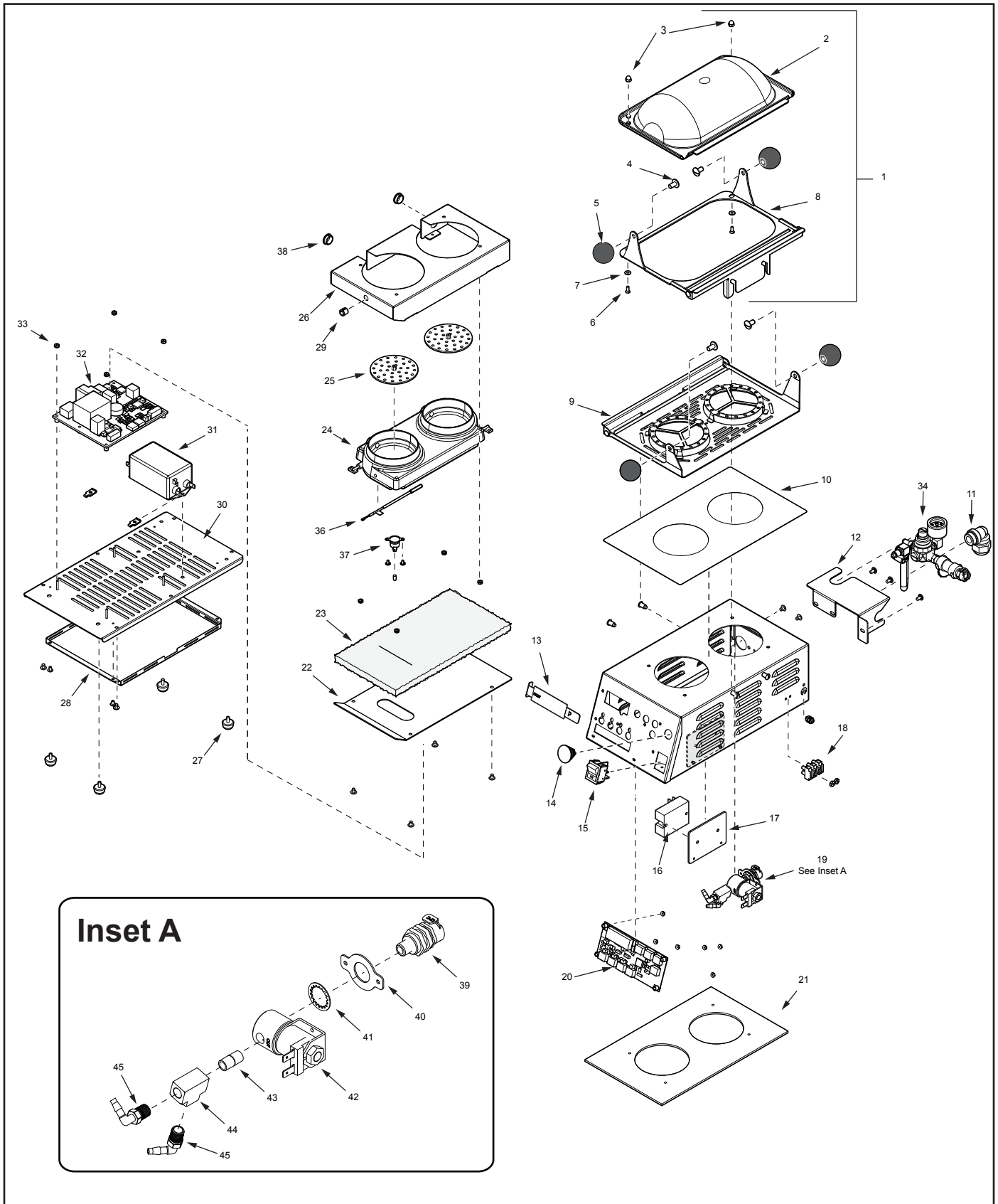

REPLACEMENT PARTS (continued)

Item	Part No.	Description	Qty.
1	0012498	Bun Cap Kit incl. 2 - 8	1
2	2180286	Bun Cap	1
3	306P152	Nut, Acorn #6-32 Low Crown w/ Centerlock	2
4	325P132	Screw, Mach 1/4-20 x 1/2"	4
5	2100138	Knob Ball	4
6	306P125	Screw Mach 6-32 x 3/8"	4
7	306P162	Washer Flat # 6, 3/8" OD X 5/32" ID X .030" THK"	4
8	0021663	Bun Cap Rivetment	1
9	0021661	Flipper Weldment	1
10	0400408	Heat Shield Pad SS-200TT	1
11	0400354	Strain Relief Elbow 90 degree	1
12	0506040	Bracket, Regulator	1
13	0012508	Display Bracket Assy. SS-200TT	1
14	4010215	Momentary Switch with Wiring	1
15	7000542	Rocker Switch Kit (Power On/Off)	1
16	7000370	Relay, Solid State	1
17	0021664	Heat Shield Plate Relay	1
18	4060304	Terminal Block 3-Pole	1
19	0012500	Solenoid Valve Assembly 230V, SS-200TT	1
20	4070147	Front Control Board	1
21	0400409	Insulation, Fiberglass SS-200TT	
22	0012504	Heat shield cover Assembly	1
23	0400410	Insulation Bottom SS-200TT	1
24	7000927	Generator Kit (Mfg. No. 9100907 only)	1
	7000926	Generator Kit (Mfg. No. 9100908 only)	1

Item	Part No.	Description	Qty.
25	0012503	Diffuser	2
26	0506027	Heat Shield SS-200TT	1
27	7000436	Rubber Head Screw Bumper (4-Pack)	4
28	0506037	False Bottom Plate SS-200TT	1
29	0400265	Bushing, Open/Close-3/8	1
30	0021665	Bottom Cover	1
31	4051001	Line Filter, Power (Mfg. No. 9100907 only)	1
32	7000979	Control Board Replacement Kit SS-200TT/SS-400TT	1
33	304P105	Nut, Hex 'KEPS' #4-40	
34	7000761	Water Regulator Kit SS-200TT	1
35	0700437	Power Cord Assy (not shown) (Mfg. No. 9100907 only)	1
	0700724	Power Cord Assy. (not shown) (Mfg. No. 9100908 only)	1
36	4050214	Thermocouple Type K 3/16" Diameter Open End	1
37	4030404	Thermostat, 1/2" Disc, Auto Reset	1
38	040P119	Bushing, Shorty 5/8"	2
39	2080117	Quick Disconnect 1/8" NPT	1
40	0506041	Quick Disconnect Plate	1
41	362P102	Lockwasher (10-Pack)	1
42	4040192	Solenoid Valve - 230 VAC (Mfg. No. 9100907 only)	1
	0012848	Solenoid Assembly, 208 Volt (Mfg. No. 9100908 only)	1
43	2190178	Nipple Pipe 1/8"	1
44	2190180	Female Tee 1/8" NPT	1
45	2190179	Elbow 1/8" NPT x 3/16" Barb	2



Corporate Headquarters

Carol Stream, Illinois

Phone: +1 (630) 784-1000

Toll Free: +1 (800) 253-2991

Fax: +1 (630) 784-1650

China Facility

Suzhou, China

Phone: +86-512-6841-3637

Fax: +86-512-6841-3907