

Manufacturing Numbers 9210825 & 9210826

Place this manual in the Toaster section
of your Equipment Manual.
Manufactured exclusively for
McDONALD'S®

BY
A.J. ANTUNES & CO.
180 KEHOE BLVD.
CAROL STREAM, ILLINOIS 60188, U.S.A.
PHONE: 1-630-784-1000
TOLL FREE: 1-877-392-7854
FAX: 1-630-784-1650
www.ajantunes.com



A.J. Antunes & Co.



UTX-200 & CTX-200

Scan with mobile device or enter URL
for product and service information.

<http://tiny.cc/ajaUTX-CTX>

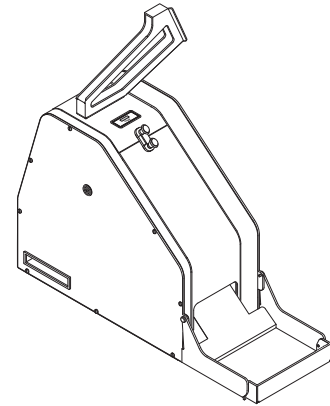

TABLE OF CONTENTS

Owner Information	2	Adjusting Toasting Quality	7
General	2	Toasting Clubs	7
Service/Technical Assistance	2	Viewing the Program Mode Settings	8
Warranty Information	2	CT Unit Status Mode	8
Specifications	3	Purging Products from the Toaster	9
Electrical Specifications & Plug Configuration	3	Shutting down the CTX-200L	9
Dimensions	3	Reset to Factory Defaults	9
Pass Through Time	3	Changing the Display Language	9
Important Safety Information	4	Maintenance	10
Installation	5	Daily Cleaning	10
Unpacking.....	5	Replacing Belt Wraps	12
Location	5	Troubleshooting	14
Assembling the Unit	6	Replacement Parts	16
Operation	7	Wiring Diagram	19
Operating Instructions	7		

LIMITED WARRANTY

The Antunes Food Service Equipment Division of A.J. Antunes & Co. provides the following limited warranty to the original purchaser of all McDonald's Equipment. All components are warranted against defects in the material and workmanship for a period of two (2) years from date of original installation.

If any part becomes defective during the period of this Warranty, Antunes Food Service will pay labor costs to an Authorized Service Agent to replace the part plus travel expenses.

WARRANTY EXCLUSIONS

- The cost of Installation.
- Equipment that has been damaged due to shipment. Purchaser should make damage claim directly upon carrier.
- Alteration, misuse, abuse.
- Improper storage or handling.
- Improper maintenance.
- Failure to follow proper Installation instructions, including electrical connection.
- Improper or unauthorized repairs.
- Scheduled Maintenance procedures as outlined in your MRC Card.
- This Warranty does not cover Consumable items. **NOTE: The Conveyor Belt wraps are consumable items that can be easily adjusted or replaced according to the Maintenance Section of this product's Owner's Manual.**
- Water pressure problems or contamination problems such as foreign material in water lines or inside solenoid valves due to an incoming water source.
- Freight, foreign, excise, municipal or other sales or use taxes.
- Consequential damages such as loss of profit, loss of time, the cost of repairing or replacing other property which is damaged, or any other incidental damage of any kind.

Antunes Food Service reserves the right to make changes in design or add improvements on any products. The right is always reserved to modify Equipment because of factors beyond our control and government regulation. Changes to Equipment do not constitute a warranty charge. This warranty is exclusive and is in lieu of all other warranties, expressed or implied, including any implied warranty of merchantability or fitness for a particular purpose, each of which is expressly disclaimed. The remedies described above are exclusive, and in no event shall A.J. Antunes & Co. or any of its Divisions be liable for special consequential or incidental damages for the breach or delay in the performance of this warranty.

This manual is for the exclusive use of licensees and employees of McDonald's Systems, Inc..
© McDonald's Corporation All Rights Reserved

OWNER INFORMATION

General

This manual is produced for the Club Toaster.

The Club Toaster is designed to toast the club portion of buns using an inclined platen conveyor. The Club Toaster uses contact toasting on both sides to provide an evenly toasted product.

This manual provides the safety, installation, and operating procedures for the Club Toaster. We recommend that this manual be read prior to installing and operating the unit.

The Club Toaster is manufactured from the finest materials available and assembled to Roundup's strict quality standards. This unit has been tested at the factory to ensure dependable trouble-free operation.

Warranty Information

Please read the full text of the Limited Warranty in this manual.

If the unit arrives damaged, contact the carrier immediately and file a damage claim with them. Save all packing materials when filing a claim. Freight damage claims are the responsibility of the purchaser and are not covered under warranty.

The warranty does NOT extend to:

- Damages caused in shipment or damage as result of improper use.
- Installation of electrical service.
- Normal maintenance as outlined in this manual.
- Malfunction resulting from improper maintenance.
- Damage caused by abuse or careless handling.
- Damage from moisture into electrical components.
- Damage from tampering with, removal of, or changing any preset control or safety device.

Service/Technical Assistance

If you experience any problems with the installation or operation of your unit, contact your Authorized Service Agency.

Fill in the information below and have it handy when calling your Authorized Service Agency for assistance. The serial number is on the specification plate located on the rear of the unit.

Purchased From: _____

Date of Purchase: _____

Model No.: _____

Serial No.: _____

Mfg. No.: _____

Network ID Number: _____

Refer to the service agency directory packaged with your manual and fill in the information below:

Authorized Service Agency

Name: _____

Phone No.: _____

Address: _____

Use only genuine Roundup replacement parts in this unit. Use of replacement parts other than those supplied by the manufacturer will void the warranty. Your Authorized Service Agency has been factory trained and has a complete supply of parts for this toaster.

You may also contact the factory at 1-877-392-7854 (North America only), or 630-784-1000 if you have trouble locating your local Authorized Service Agency.

IMPORTANT! Keep these instructions for future reference. If the unit changes ownership, be sure this manual accompanies the equipment.

SPECIFICATIONS

Electrical Specifications & Plug Configuration

Model & Mfg. No	Line Voltage	Phase	Power	Max Amps/ Line	Freq.	Plug Description and Configuration
CTX-200L 9210825	208 V	1	3.3 kW	16	60	 Pin & Sleeve 1 Phase
	240 V	1	4.3 kW	18	60	
CTX-200L 9210826	208 V	1	3.3 kW	16	60	 NEMA L6-30P
	240 V	1	4.3 kW	18	60	

Dimensions

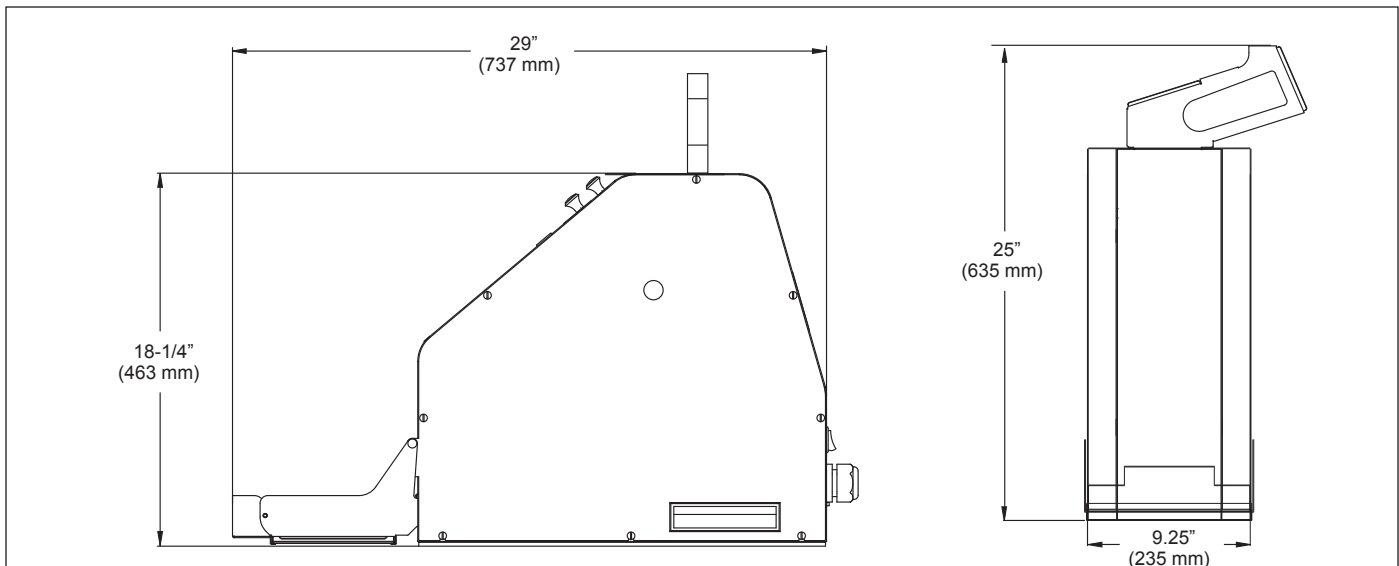

Pass Through Time

For all CTX-200 units the pass through time is 22 seconds (+/- 2 seconds).

⚠ WARNING ⚠

ELECTRICAL SHOCK HAZARD. FAILURE TO FOLLOW THE INSTRUCTIONS IN THIS MANUAL COULD RESULT IN SERIOUS INJURY OR DEATH.



- Electrical ground is required on this appliance.
- Do NOT modify the power supply cord plug. If it does not fit the outlet, have a proper outlet installed by a qualified electrician.
- Do NOT use an extension cord with this appliance.
- Check with a qualified electrician if you are unsure if the appliance is properly grounded.

⚠ CAUTION ⚠



All electrical connections must be in accordance with local electrical codes and any other applicable codes.

IMPORTANT SAFETY INFORMATION



Throughout this manual, you will find the following safety words and symbols that signify important safety issues with regards to operating or maintaining the equipment.

 **WARNING** 



GENERAL WARNING. Indicates information important to the proper operation of the equipment. Failure to observe may result in damage to the equipment, severe bodily injury or even death.

 **WARNING** 

ELECTRICAL WARNING. Indicates information relating to possible shock hazard. Failure to observe may result in damage to the equipment and/or severe bodily injury or death.

 **CAUTION** 

GENERAL CAUTION. Indicates information important to the proper operation of the equipment. Failure to observe may result in damage to the equipment.

 **WARNING** 

HOT SURFACE WARNING. Indicates information important to the handling of equipment and parts. Failure to observe caution could result in personal injury.

In addition to the warnings and cautions in this manual, use the following guidelines for safe operation of the unit.

- Read all instructions before using equipment.
- For your safety, the equipment is furnished with a properly grounded cord connector. Do NOT attempt to defeat the grounded connector.
- Install or locate the equipment only for its intended use as described in this manual. Do NOT use corrosive chemicals in this equipment.
- Do NOT operate this equipment if it has a damaged cord or plug, if it is not working properly, or if it has been damaged or dropped.
- This equipment should be serviced by qualified personnel only. Contact the nearest Authorized Service Agency for adjustment or repair.
- Do NOT block or cover any openings on the unit.
- Do NOT immerse cord or plug in water.
- Keep cord away from heated surfaces.
- Do NOT allow cord to hang over edge of table or counter.
- Do NOT clean this appliance with a water jet.

The following warnings and cautions appear throughout this manual and should be carefully observed.



- Turn the unit off, wait for the cool-down procedure to complete its cycle (45 minutes), and disconnect the power cord before performing any service or maintenance on the unit.

NOTE: Turning off the power switch does NOT turn off all power to the unit. When the unit is plugged in and turned off, an LED light will flash to indicate that the power cord is plugged in.

- The procedures in this chapter may include the use of chemical products. These chemical products will be highlighted with bold face letters followed by the abbreviated **HCS** (Hazard Communication Standard). See Hazard Communication Standard manual for the appropriate Material Safety Data Sheets (MSDS).
- The equipment should be grounded according to local electrical codes to prevent the possibility of electrical shock. It requires a grounded receptacle with separate electrical lines, protected by fuses or circuit breaker of the proper rating.
- Bread may burn. Therefore toasters must not be used near or below curtains or other combustible walls and materials. Failure to maintain safe operating distances may cause discoloration or combustion.



This equipotentiality symbol shows external functional grounding connection.

 **WARNING** 

To avoid possible personal injury and/or damage to the unit, all inspections, tests, and repair of electrical equipment should be performed by QUALIFIED SERVICE PERSONNEL. The unit MUST be completely shut down and unplugged before any internal servicing, except when electrical tests are required. Use extreme care during electrical circuit tests. Live circuits will be exposed.

INSTALLATION

Unpacking

1. Remove the CTX-200L (Figure 1) and all packing materials from the shipping carton. Then open the accessories box and remove all its contents. It should contain the following:
 - 1 Bun Feeder (Figures 1 and 2)
 - 1 Bun Buffer (Figures 1 and 2)
2. Remove all packing materials and protective coverings from the unit and parts.
5. Wash the accessories in hot, soapy water, rinse in clean water, and allow to air dry. Then wipe these parts with a clean cloth dampened with sanitizer and allow to air dry.

NOTE: Handle the accessories with care. If an accessory becomes bent or damaged, it may not attach to the unit correctly, which may affect normal operation.

NOTE: If any parts are missing or damaged, contact A.J. Antunes Technical Service IMMEDIATELY at 1-877-392-7854 (North America only), or 630-784-1000.

Location

When placing the toaster into service, pay attention to the following guidelines:

- Make sure power is off and the toaster is at room temperature.
- Do NOT block or cover any openings on the unit.
- Do NOT immerse cord or plug in water.
- Keep cord away from heated surfaces.
- Do NOT allow cord to hang over edge of table or counter.

Connect the unit to the power supply. Refer to the specification plate for the proper voltage.

NOTE: The CTX-200L and the UTX-200L are designed to sit side by side. The UTX-200L can be placed on the right or left side of the CTX-200L by putting the Bun Compression Knob of the UTX-200L on the side that is NOT flush against the CTX-200L.

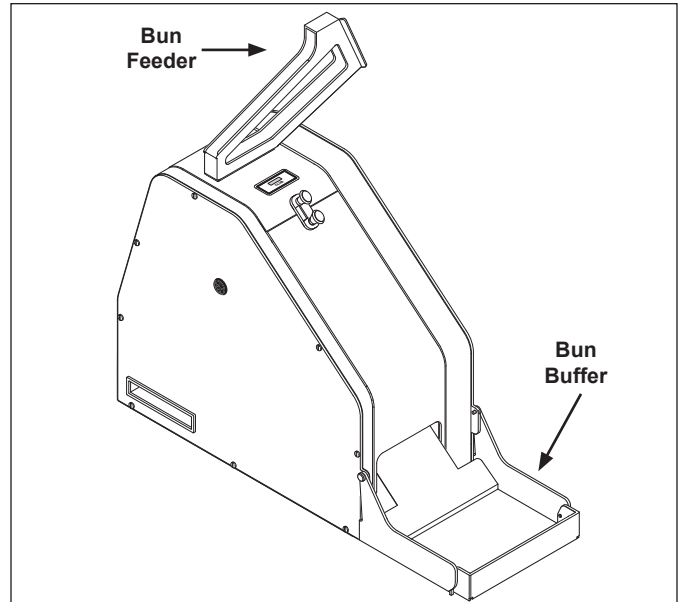

Figure 1. CTX-200L Club Toaster

⚠ WARNING ⚠

ELECTRICAL SHOCK HAZARD. FAILURE TO FOLLOW THE INSTRUCTIONS IN THIS MANUAL COULD RESULT IN SERIOUS INJURY OR DEATH.

- Electrical ground is required on this appliance.
- Do NOT modify the power supply cord plug. If it does not fit the outlet, have a proper outlet installed by a qualified electrician.
- Do NOT use an extension cord with this appliance.
- The toaster should be grounded according to local electrical codes to prevent the possibility of electrical shock. It requires a grounded receptacle with separate electrical lines, protected by fuses or circuit breaker of the proper rating.
- Check with a qualified electrician if you are unsure if the appliance is properly grounded.

⚠ CAUTION ⚠

All electrical connections must be in accordance with local electrical codes and any other applicable codes.

⚠ CAUTION ⚠

Bread may burn. Therefore toasters must not be used near or below curtains or other combustible walls and materials. Failure to maintain safe operating distances may cause discoloration or combustion.

⚠ CAUTION ⚠

NEVER unplug the power cord while the unit is running! Use the proper shutdown procedure before unplugging the power cord.

INSTALLATION (continued)

Assembling the Unit

Assemble the unit as shown in Figures 1 and 2.

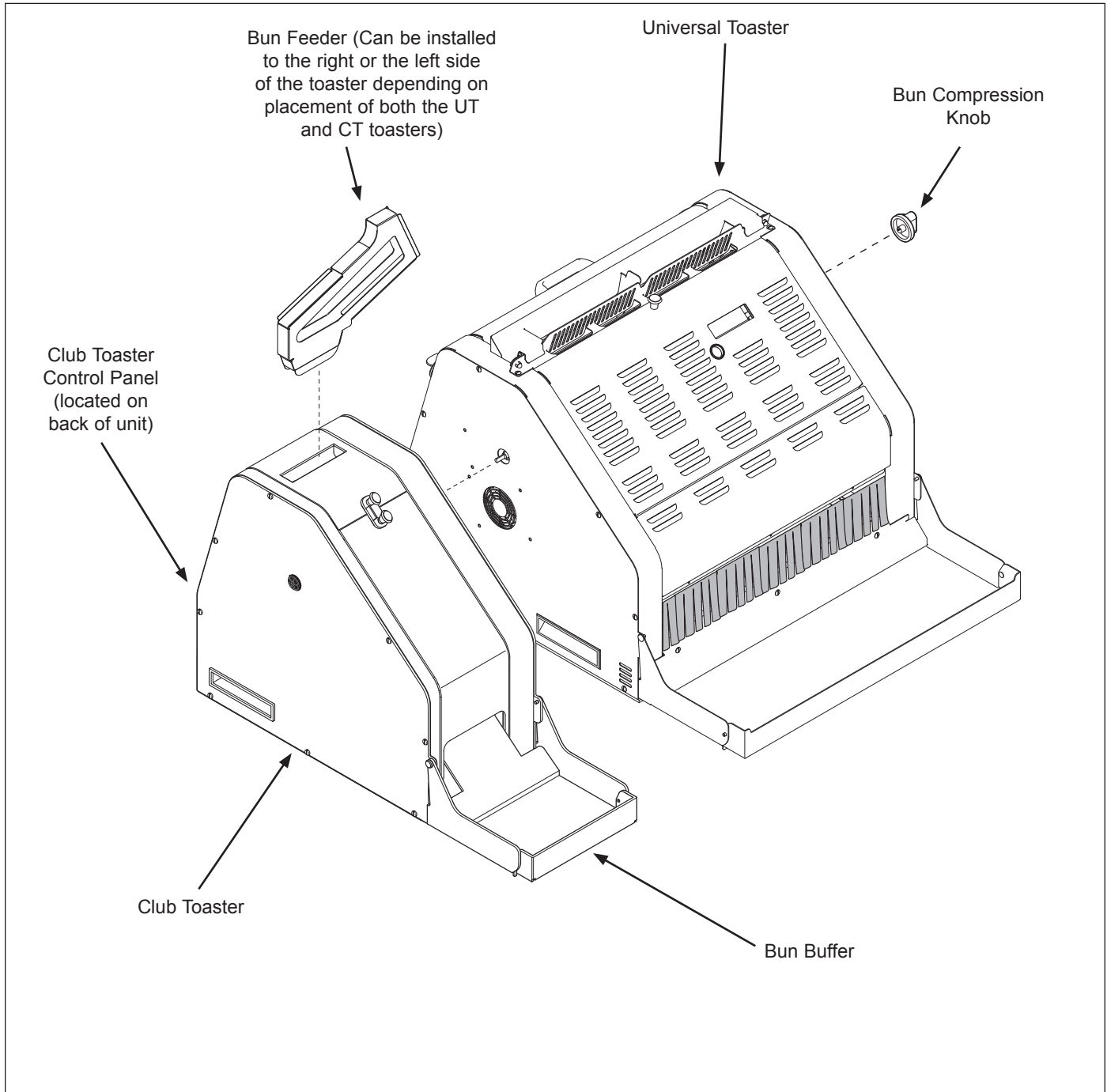

Figure 2. Club Toaster Accessories and Placement

OPERATION

Operating Instructions

Follow these steps to start the Club Toaster:

1. Turn on the Power Switch located at the back of the unit. There will be a 20-second countdown as the unit sets defaults.
2. The unit will start to warm up and will show the **Wait** message in the display (Figure 3).

NOTE: The Control Panel and display are located on the back of the unit.

3. When the unit reaches operating temperature, the display will read **Ready** (Figure 4).
4. The unit is ready for operation.

NOTE: If the toasting quality needs to be adjusted, refer to the section titled “Adjusting Toasting Quality” in the Operation section of this manual.

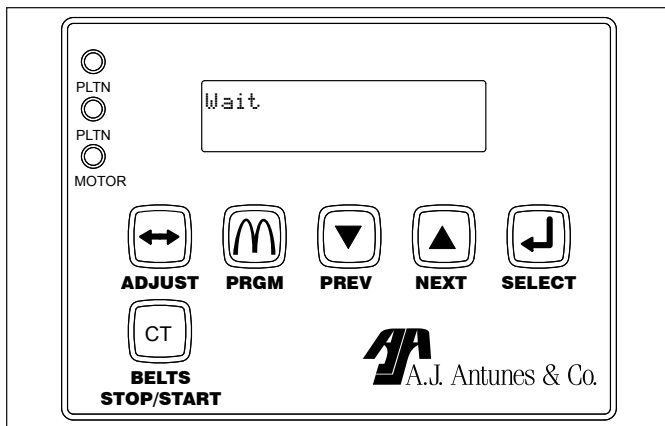

Figure 3. Club Toaster Wait Display

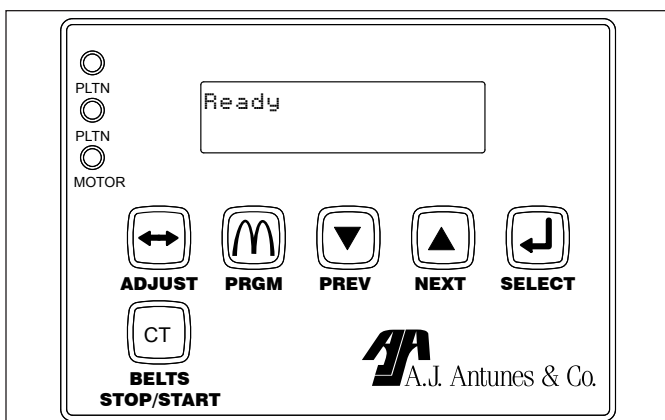

Figure 4. Club Toaster Ready Display

Toasting Clubs

Follow these steps to toast clubs with the Club Toaster:

1. Make sure the unit is turned on and that the display reads **Ready**.
2. Insert the club into Bun Feeder (Figure 5).
3. The club will emerge from the toaster into the Bun Buffer.

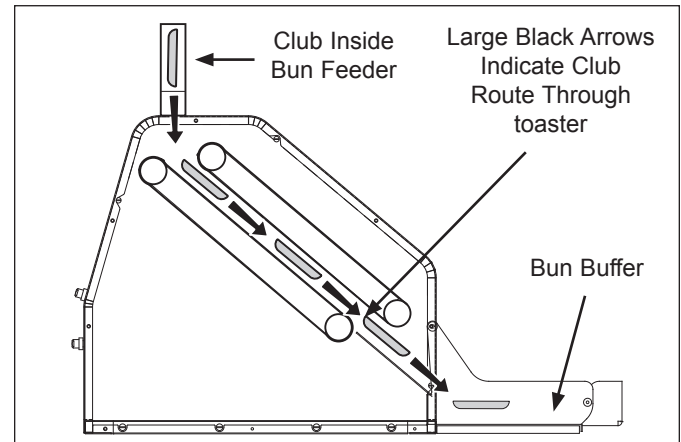

Figure 5. CTX-200L Toasting Route

NOTE: For all CTX-200 units, the product pass-through time is 22 seconds (+/- 2 seconds).

Adjusting Toasting Quality

Follow these steps to adjust toasting quality.

1. At the back Control Panel, press and release the **ADJUST** button (Figure 6).
2. Use the **PREV** and **NEXT** buttons to adjust the toasting quality to lighter or darker respectively (Figure 6).

NOTE: Pressing the PREV button decreases toasting darkness. Pressing the NEXT button increases toasting darkness.

3. Test several clubs to verify that the product is toasting at the desired quality.
4. If the toasting quality needs further adjustment, repeat Steps 1 through 3 as necessary.

NOTE: This setting is maintained when the unit is powered off. The adjustment range is +/- 10% of cycle time. Therefore, each adjustment represents a 1% change toward the desired result. Two bars on the display indicate the adjustment is in the center position.

OPERATION (continued)

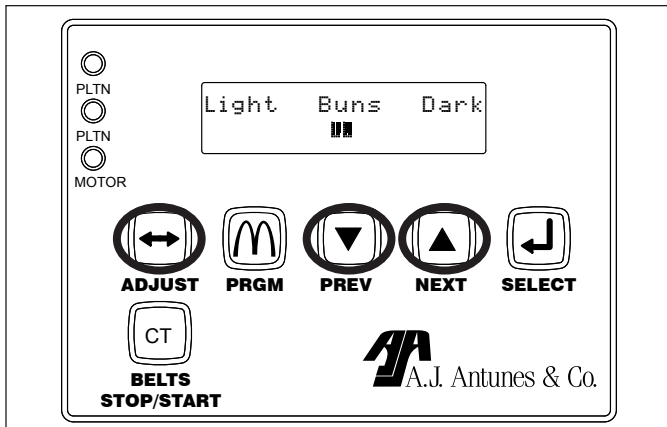

Figure 6. Adjusting Toasting Quality

Viewing the Program Mode Settings

Follow these steps to view these settings:

1. From the Ready or Wait modes, press and hold the **PRGM** button for 3 seconds.
2. The following appears on the display:

```
Program Club
Press Select
```
3. If desired, use the **NEXT** or **PREV** button to scroll through the following categories:
 - Speed
 - Units (F/C) (default setting is F)
 - Top Temp
 - Bottom Temp
4. When the desired category is reached, press the **SELECT** button ONCE. This will cause the selected category value to blink indicating it is in edit mode.

NOTE: The current setting will be the FIRST setting shown in the display.

5. Press the **PREV** or **NEXT** buttons while the value is blinking to change adjust the setting.

Note: Do NOT change any of these settings for ANY reason! For assistance in changing these options, please call the factory.

6. When you are finished viewing settings, press the **PRGM** button to return to the Ready screen or wait 10 seconds until the Ready screen appears.

NOTE: The unit will exit the Program Mode after 10 seconds of inactivity.

Club Toaster Settings

The following table describes the recommended Club Toaster operating settings.

Setting	Value
Bottom Temp. (Lower Platen)	570°F (299°C)
Top Temp (Upper Platen)	570°F (299°C)
Speed (22 seconds)	1700

NOTE: If you wish to change any of the above settings, contact the factory for instructions.

CT Unit Status Mode

This mode provides feedback on unit performance. No adjustments can be made in this mode. Also, the display remains on the selected screen in this mode until you switch screens or exit the Unit Status mode.

Follow these steps to view the Unit Status mode:

1. From any operation mode (Ready or Wait) press and hold the **ADJUST** button for 3 seconds.
2. The following appears on the display in sequence:
 - **Speed-Motor-Set Pt**
 - **Total Hours**
 - **Controls Temp** (Air temperature inside the electrical enclosure)
 - **Top Temp** (Actual temperature and set point temperature)
 - **Bottom Temp** (Actual temperature and set point temperature)
 - **Smart Kitchen Network Not Detected**

OPERATION (continued)

Purging Products from the Toaster

During normal operation, if it ever becomes necessary to purge a product from the toaster, follow these steps:

1. While in Ready or Wait mode, press and hold the **NEXT** button until the product have been purged from the unit. This will speeds the unit up, forcing the product out of the toaster.
2. Once the product is purged, release the **NEXT** button and the unit will return to normal operating speed.

NOTE: Product is always purged out of the front of the Toaster using the NEXT button. It is NOT possible to purge product backwards through the unit. Only the NEXT button will purge product.

Shutting down the CTX-200L

Follow these steps to shut down the toaster:

1. Turn the power off.
2. The fans continue to run and the display reads:
OK to Clean
45 minutes Remaining
3. The Cool Down mode will continue for 45 minutes, counted down on the display, and the unit will shut down automatically when complete.

NOTE: If the unit requires any internal maintenance, be sure to completely shut down the unit.

⚠ IMPORTANT ⚠

Do NOT unplug the power cord when the unit is in cool down mode. Wait for the 45-minute cool down period to complete before unplugging the power cord.

⚠ WARNING ⚠

To avoid possible personal injury and/or damage to the unit, all inspections, tests, and repair of electrical equipment should be performed by QUALIFIED SERVICE PERSONNEL. The unit MUST be completely shut down and unplugged before performing any internal service, except when electrical tests are required. Use extreme care during electrical circuit tests. Live circuits will be exposed.

Reset to Factory Defaults

Inadvertent changes to the settings of the CTX-200L could affect how the unit operates. If a fault message appears, it is recommended that you first attempt to restore the settings to the factory defaults. This will restore all settings and parameters to McDonald's corporate specifications.

NOTE: The CTX-200L should NOT be unplugged during normal operation or during the 45-minute cool down period.

Follow these steps to reset the Factory Defaults:

1. Turn the power off.
2. Turn the power on.
3. Listen for the unit to click three times, then immediately press and hold the **PREV** and **NEXT** buttons until the display reads `Factory Defaults Set.`

NOTE: The display will then go blank.

4. Turn the power off and then back on.
5. Wait for the 20-second countdown to complete.

NOTE: The unit will then display `Muffin Wait.`

6. Preheat the unit and test for proper operation.

NOTE: If after resetting the Factory Defaults the unit continues to display a fault/error message, turn the power off and unplug the power cord. Wait a few seconds and then plug the power cord back in. Then repeat steps 2 through 6. If the unit still displays a fault/error message, immediately call your Authorized Service Agency for assistance.

Changing the Display Language

Follow these steps to change the display language between English and Spanish:

1. At any time during power off (but connected to power), cool down, warm-up, or normal operation, press the **SELECT** button.
2. Press the **NEXT** button to select the desired language and then release the button.
3. After 3 seconds, the change is stored into memory.

MAINTENANCE

⚠ WARNING ⚠

The unit will remain hot to the touch while it is cooling down. Personal injury and burns may result from touching the unit before it is finished cooling down.

NOTE: If at any time the unit displays an error message or if it fails to operate properly, contact the factory immediately for service.

Daily Cleaning

1. Turn the power off.
2. The toaster enters a cool down mode and displays **OK to Clean**. The fans continue to run. This cool down mode continues for 45 minutes and shuts the unit down automatically when complete.

NOTE: You do **NOT** need to wait for the count down to complete. Continue with the cleaning steps as soon as you see **OK to Clean**.

3. Wearing heat-resistant gloves, remove the Bun Feeder and Bun Buffer from the toaster (refer to Figure 1).
4. Wipe the outside of the toaster with a clean towel dampened with **KAYQUAT II™ Sanitizer (HCS)** and allow to air dry.

NOTE: The Belt Wraps will continue to turn during the cool down period. This is normal. It will be necessary to stop the belts to clean them. To do so, press the **BELTS START/STOP** button. Press the **BELTS START/STOP** button again to resume belt rotation (Figure 7).

5. Wash the Bun Feeder and Bun Buffer at a three-compartment sink. Rinse with clear water and allow to air dry.
6. Wipe the Bun Feeder and Bun Buffer with a clean cloth dampened with **KAYQUAT II™ Sanitizer (HCS)** and allow to air dry.

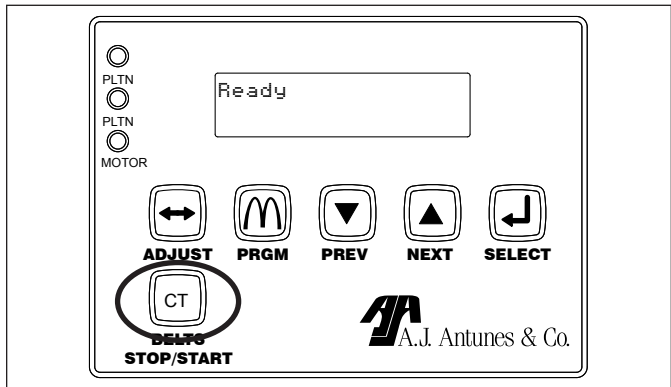

Figure 7. Belts Start/Stop Button (CT Button)

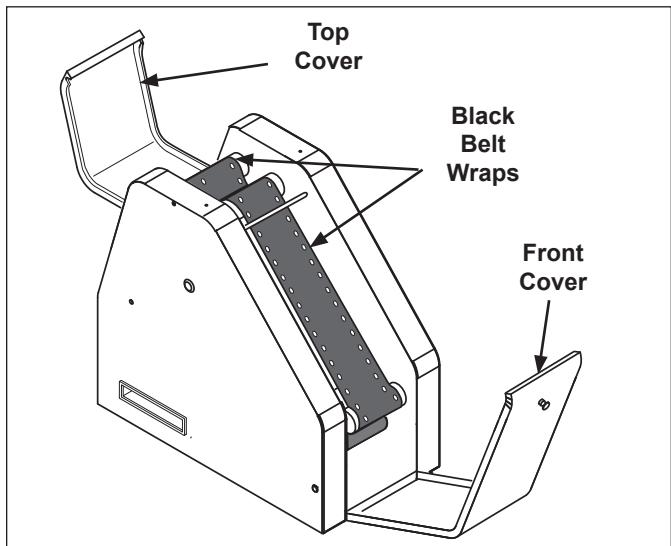







Figure 8. Accessing Belt Wraps

MAINTENANCE (continued)

Cleaning and Sanitizing the Belt Wraps

1. Open the Front Cover and Top Cover (Figure 8).
Press  (Figure 7) to temporarily stop the Belt Wraps from turning.
2. Wearing heat-resistant gloves, wipe the outer side of the upper Belt Wrap with a clean towel dampened with **McD® All-Purpose Super Concentrate (APSC) (HCS)** (Figure 9).
3. Press  to rotate the Belt Wrap to expose the uncleaned portion of the Belt Wrap. Then, press  again to stop the Belt Wraps from turning.
4. Wipe the newly exposed portion of the Belt Wrap with a clean towel dampened with **McD® All-Purpose Super Concentrate (APSC) (HCS)**.
5. Next, sanitize the Belt Wrap by wiping it with a clean towel dampened with **KAYQUAT II™ Sanitizer (HCS)**.
6. Press  to rotate the Belt Wrap to expose the uncleaned portion of the Belt Wrap. Then, press  again to STOP the Belt Wraps from turning.
7. Wipe the newly exposed portion of the Belt Wrap with a clean towel dampened with **KAYQUAT II™ Sanitizer (HCS)**.
8. Repeat steps 2 through 7 on the Lower Belt Wrap.

NOTE: Be sure to clean and sanitize both Belt Wraps completely. Failure to properly clean the Belt Wraps will shorten the life of the Belt Wraps and result in poor toaster performance.

NOTE: Replace the Belt Wraps if they show excessive wear and tear. To obtain new Belt Wraps, contact the factory at 1-877-392-7854 (North America only) or 630-784-1000.

NOTE: Belt Wraps should be removed ONLY during Belt Wrap replacement or when required in a service situation.

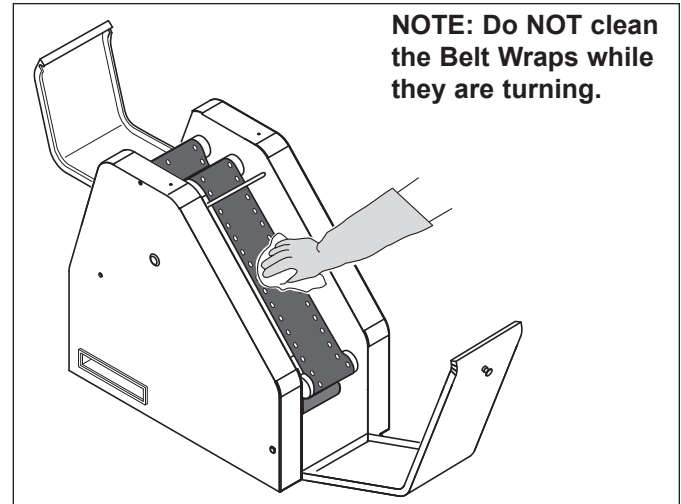

Figure 9. Cleaning the Belt Wraps

MAINTENANCE (continued)

Replacing Belt Wraps

Over time, the Belt Wraps will begin to show signs of wear. This wear appears in the form of tears or discoloration of the belt. The Belt Wraps should be replaced at least once a year.

NOTE: Belt Wraps should be removed ONLY during Belt Wrap replacement or when required in a service situation.

REMOVING BELT WRAPS

1. Turn the power off.
2. The toaster enters a cool down mode and displays **OK to Clean**. The fans continue to run. This cool down period continues for 45 minutes and shuts the unit down automatically when complete.

NOTE: You do NOT need to wait for the count down to complete. Continue with the steps as soon as you see **OK to Clean.**

3. Remove the Bun Feeder and Bun Buffer from the toaster (refer to Figure 1):
4. Press  to stop the Belt Wraps from rotating.
5. Open the Front Cover and Top Cover (Figure 8).
6. Refer to Figure 10. Push up and then drop down both of the Front and Rear Bottom Rollers until they lock into place. This will remove the tension on both Belt Wraps.
7. Locate the Connecting Pin on both Belt Wraps (rotate belts by hand if necessary). Disconnect the ends of the Belt Wraps by sliding one end of the Belt off the pin (Figure 11).
8. Remove both Belt Wraps and discard.

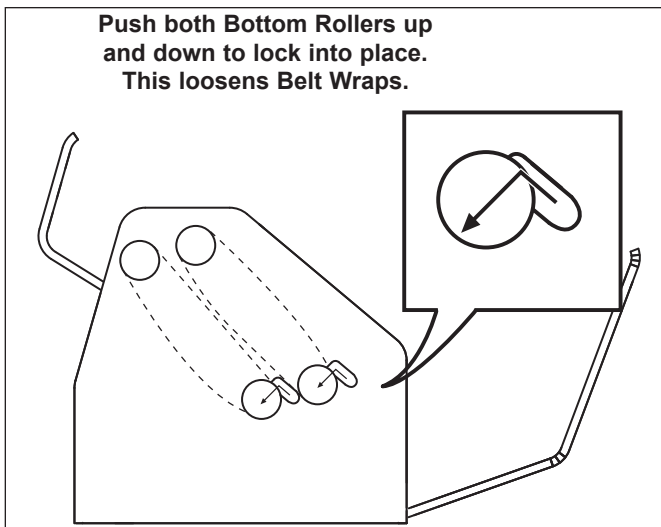

Figure 10. Loosening Belt Wraps

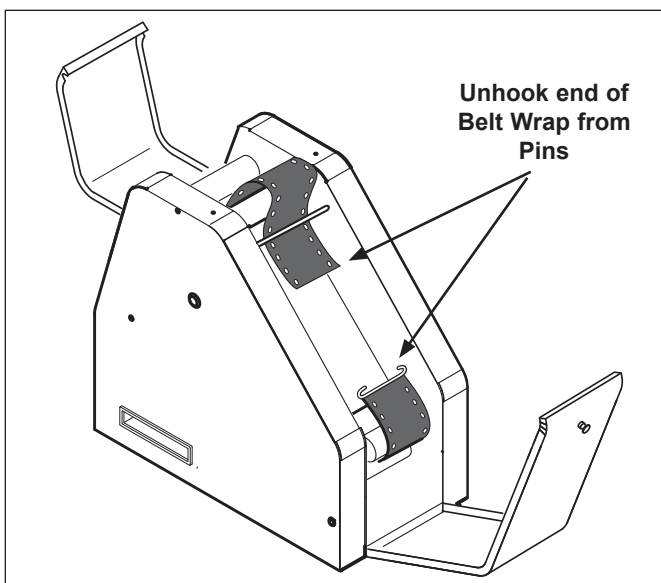

Figure 11. Disconnecting Belt Wraps

MAINTENANCE (continued)

INSTALLING BELT WRAPS

Follow this procedure to install new Belt Wraps.

NOTE: Install Belt Wraps with the studs facing the **INSIDE** of the unit. Belt Wraps **must** be installed so that the gap of one Belt Wrap is located in the opposite position of the gap on the other Belt Wrap (Figure 13).

1. Wipe both sides of the new Belt Wraps with **KAYQUAT II™ Sanitizer (HCS)** and allow to air dry.

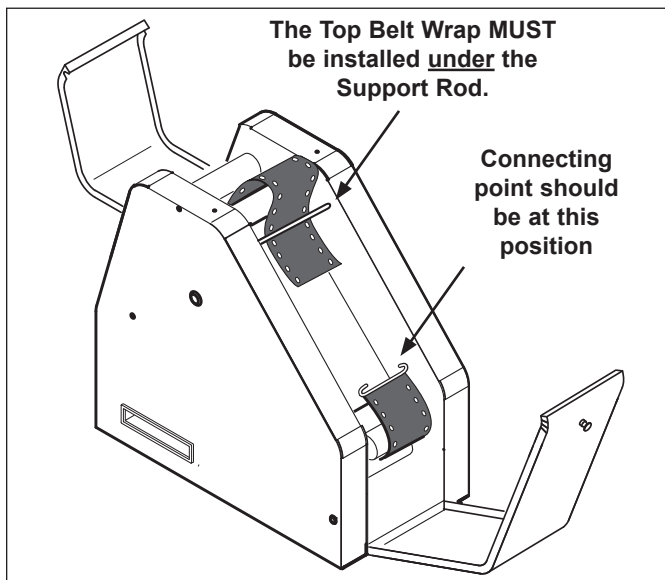

Figure 12 Installing Belt Wraps

NOTE: To obtain new Belt Wraps, contact the factory at 1-877-392-7854 (North America only) or 630-784-1000.

2. Ensure that both lower rollers are locked in the upper position (Figure 10).
3. Install the front Belt Wrap around the top front roller with the Connecting Pin towards the bottom of the unit (Figure 12).
4. Thread the Belt Wrap through the toaster and pull it around the lower front roller (Figure 12).

NOTE: Make sure the front Belt Wrap is threaded **UNDER** the Support Rod. Also, make sure that the Belt Wrap studs are facing the **INSIDE** (Figure 12).

5. Connect the ends of the Belt Wrap by sliding the top end over both sides of the Connecting Pin (Figures 12 and 13).

NOTE: Refer to Figure 13 for the proper connection point locations when installing Belt Wraps.

NOTE: The bottom Belt Wrap should be installed by threading the Belt Wrap around the bottom rear roller, up through the unit, and around the back top roller. The connecting pin must face the bottom of the unit. The connection point must match Figure 14.

6. Return the lower rollers to full tension by lifting up and then pulling down on each roller to lock it in place (Figure 14).
7. Close the Top Cover and Front Cover and reattach the Bun Feeder and Bun Buffer.
8. Press **CT** to resume belt rotation. Place the unit back into operation.

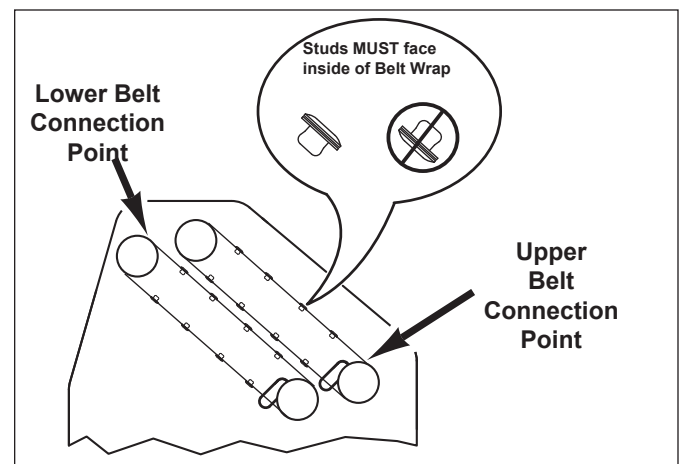

Figure 13. Proper Belt Wrap Installation

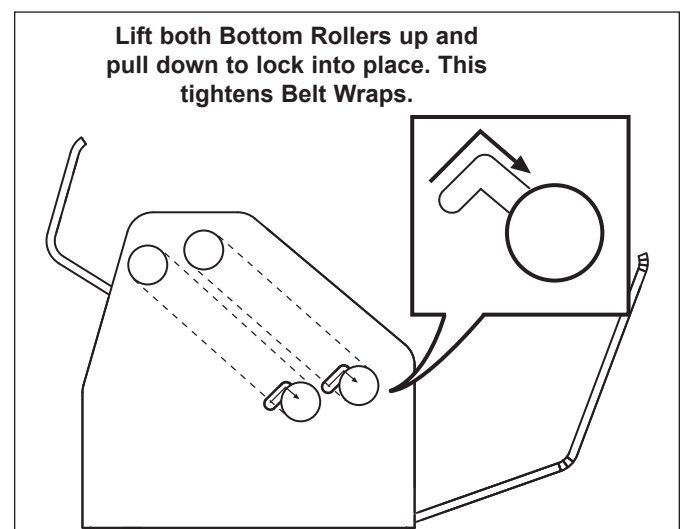

Figure 14. Restoring Belt Wrap Tension

TROUBLESHOOTING

⚠ CAUTION ⚠

To avoid possible personal injury and/or damage to the unit, all inspections, tests, and repair of electrical equipment should be performed by **QUALIFIED SERVICE PERSONNEL**. The unit **MUST** be completely shut down and unplugged before servicing, except when electrical tests are required. Use extreme care during electrical circuit tests. Live circuits will be exposed.

Problem	Possible Cause	Corrective Action
No display. No light on Power Switch.	Unit not plugged in.	Plug the power cord into the appropriate outlet.
	Hi-Limit thermostats are tripped.	Reset Hi-Limit thermostats.
	Circuit Breaker tripped.	Reset Circuit Breaker.
	Power Cord and/or plug are damaged.	Contact your maintenance person or Authorized Service Agency.
	Inoperable Power Switch.	
Belt wraps stop turning, but conveyor chain continues to turn.	Underside of Belt and Conveyor Chain have excessive buildup.	Clean Belt Wrap as described in the Maintenance section of this manual.
Product is getting stuck inside the toaster.	Belt Wraps are dirty, worn, or need replacement.	Inspect the Belt Wraps. Replace or clean according to the Maintenance section of this manual.
Unit displays the following message: Conveyor Motor Fault	Product is getting stuck in the conveyor system or the conveyor system is jammed.	Refer to the Operation and Maintenance sections of this manual for proper compression settings and cleaning procedures.
	The motor controller circuit has failed or is inoperable.	Call your Authorized Service Agency for service.
Unit displays the following message: SSR Failure - System Stopped	A relay has failed, preventing proper heater control.	The toaster cannot be operated with this kind of failure. Contact your Authorized Service Agency for service.
Unit displays the following message: Platen Fault	A heater or relay in the Platen circuit has failed.	Contact your Authorized Service Agency for service.

TROUBLESHOOTING (continued)

Problem	Possible Cause	Corrective Action
The unit displays the following message: Upper Sensor Fail Lower Sensor Fail NOTE: A thermocouple which has become grounded will cause erratic controller behavior	The Thermocouple in the Platen circuit has failed.	The toaster cannot be operated with this type of failure. Contact your Authorized Service Agency for service.
	A control relay has a short or the Thermocouple is not pushed into the Platen correctly.	The toaster will open the C1 contactor, disabling the toaster. Contact your Authorized Service Agency for service.
The overtemp thermocouple temperature is greater than 250°F (121°C) but less than 350°F (176°C).	There is a problem with the main convection blower.	The toaster will shut down. Allow the toaster to cool down and restart. If this condition persists, contact your Authorized Service Agency for service.
The overtemp thermocouple temperature is greater than 350°F or an open thermocouple condition exists.	There is a problem with the main convection blower.	The toaster will shut down. Allow the toaster to cool and then restart. If this condition persists, contact your Authorized Service Agency for service.
The unit is running too hot.	Cooling Fan failure.	The toaster will operate normally until the compartment ambient temperature exceeds 160°F (71°C). At this point, the toaster will shut down. Contact your Authorized Service Agency for service.
Unit displays the following message: WARNING! Power Fault Unplug now!!!	Contactors and control relay failures. Unit has detected IR current or rising Platen temperature with the power off.	Immediately unplug the power cord and call your Authorized Service Agency for service. The unit must not be operated with this kind of failure.

REPLACEMENT PARTS

⚠ CAUTION ⚠

To avoid possible personal injury and/or damage to the unit, all inspections, tests, and repair of electrical equipment should be performed by **QUALIFIED SERVICE PERSONNEL**. The unit should be completely shut down and unplugged before servicing, except when electrical tests are required. Use extreme care during electrical circuit tests. Live circuits will be exposed.

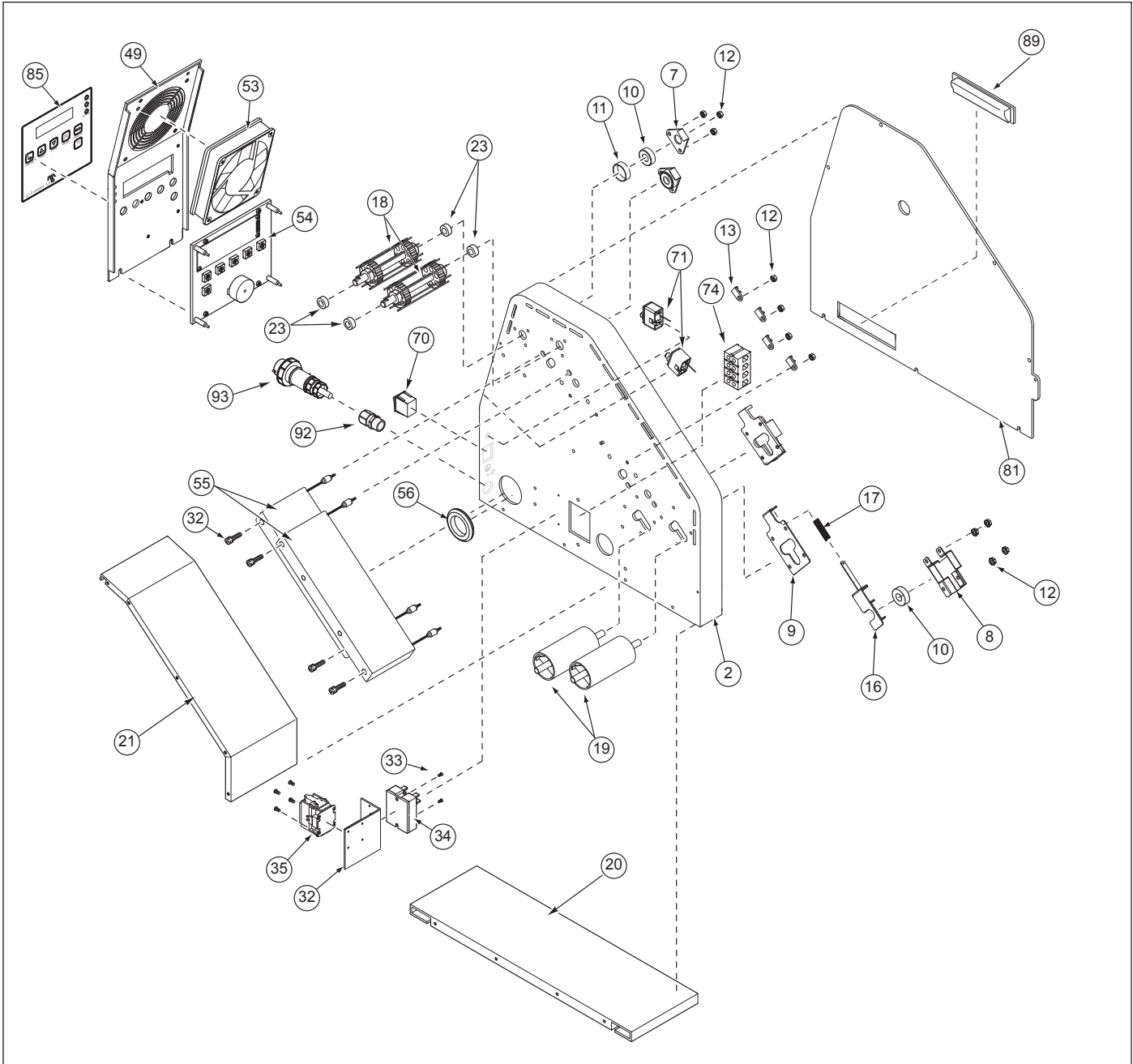

REPLACEMENT PARTS (continued)

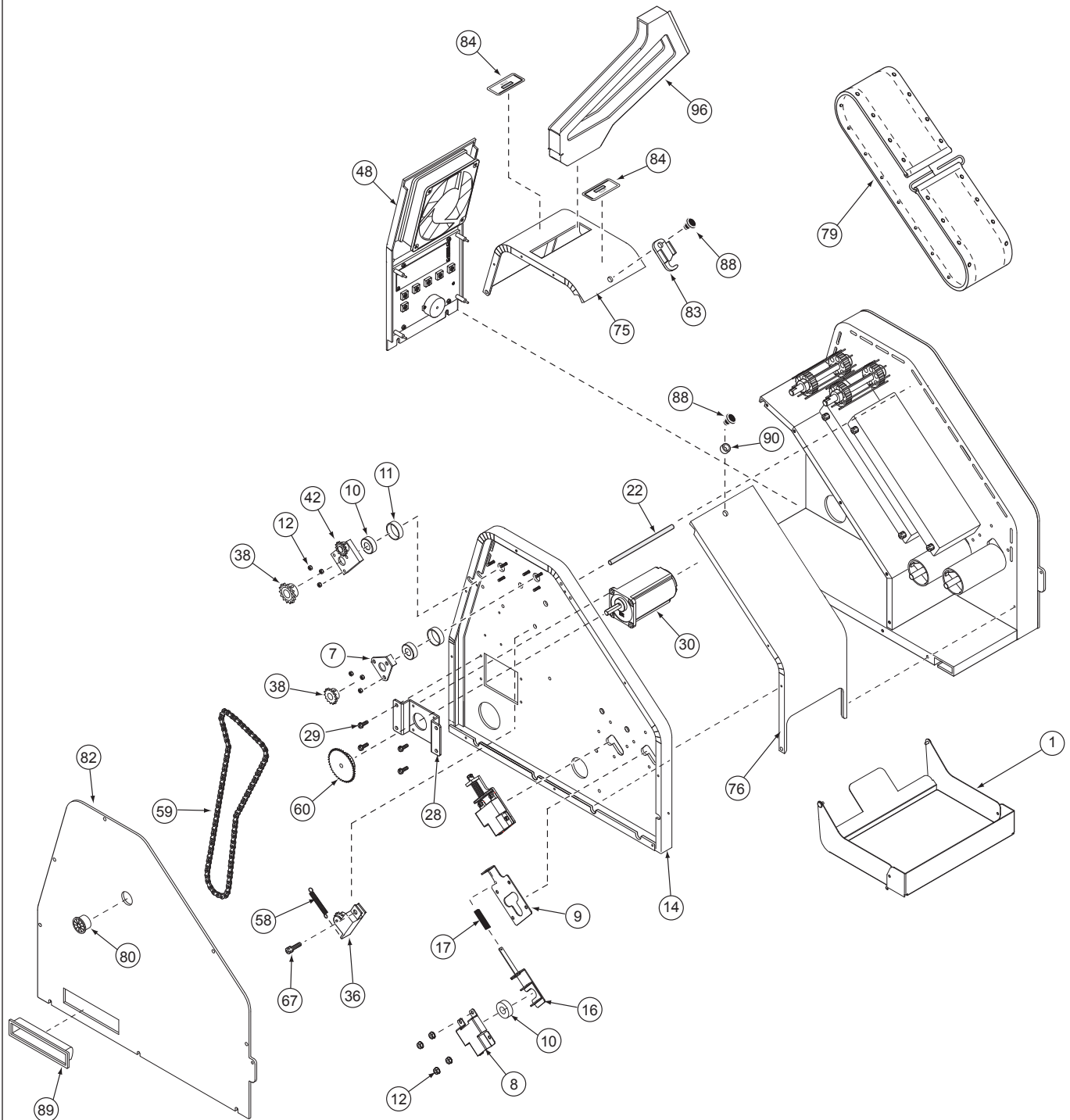

REPLACEMENT PARTS (continued)

Item	Part No.	Description	Qty.
1	0011957	Bun Collection Chute Assembly	1
2	0011958	RH Frame Assembly	1
3	0021386	Bearing Bracket Wldmnt-RH	2
7	0504484	Retainer, Bearing	2
8	0504493	Bracket, Tensioner	4
9	0504494	Plate, Tensioner	4
10	2150186	Bearing	8
11	2150260	Spacer, Bearing	4
12	3100146	Nut Hex Keps #10-32	18
13	4060130	Tie Anchor Mount #10	4
14	0011959	LH Frame Assembly	1
16	0021385	Bearing Bracket Wldmnt-LH	4
17	0600141	Spring, Compression	4
18	0011961	Drive Pulley Assembly	2
19	0021377	Idler Roller Weldment	2
20	0504158	Plate, CT Main Base	1
21	0504164	Panel, Top Elect Enclosure	1
22	0800385	Rod, Cover Support	1
23	2120175	Spacer, Pulley	4
28	0504490	Bracket, Motor Mounting	1
29	3100188	Socket Head Cap Screw	4
30	4000186	Motor	1
32	0504489	Heat Sink	1
33	3080104	Screw mach. #08-32 X 3/8 Sltrshd	6
34	4050237	Relay, Solid State, Dual Pole	1
35	4050236	Contact, 2 Pole Normally Open	1
36	0011968	Drive Tensioner Assembly	1
	0504486	Tensioner, Drive Chain	1
	2150179	Sprocket, 25B14 1/2" Bore	1
	2150250	Bearing, Flanged	1
	3000122	Ring, Retaining 1/4"	2
	3030135	Pin, Tensioner	1
42	0011969	Idler Sprocket Assembly	1
43	0021384	Idler & Brg Retainer Weldment	1
	0504491	Retainer, Idler & Brg	1
	2150259	Pin, Bearing/Idler	1
	2150258	Bearing, Idler	1
	3000124	Ring, Retaining 3/8"	1
48	0011970	Electrical Panel Assembly	1
49	0021374	Rear Cover Panel Weldment	1

Item	Part No.	Description	Qty.
53	4000132	Fan, Blower	1
54	4070114	Display Board	1
55	0100255	Platen, Club Toaster	2
56	0400329	Grommet, Rubber 2" Dia.	1
57	0504505	Shim, Shoulder Bolt	8
58	0600143	Spring, Extension	1
59	2150255	Chain, Drive 118 Links	1
60	2150264	Sprocket, 25B24 3/8 Bore	1
67	3250181	Bolt, Shoulder 5/16-18 X 3/4"	1
70	4010220	Switch, Rocker 25a, 250v	1
71	4030352	Thermostat, Hi-Limit 700	2
72*	4050234	Thermocouple Type "K"	2
73*	4060374	Ground Lug, Copper	1
74	4060392	Terminal Block S-series	1
75	0021378	Top Cover Weldment	1
76	0021379	Front Cover Panel Weldment	1
77*	0200253	Gasket, Base 16 3/4" Lg	2
78*	0200254	Gasket, Base 9" Lg	2
79	0400348	Belt Assembly, CT Drive	2
80	0400365	Bushing, 1" Universal	2
81	0504162	Panel, Rh Outside Cover	1
82	0504163	Panel, LH Outside Cover	1
83	0504495	Cover, Latch	1
84	1001184	Label, Club	2
85	1001185	Label, CT Control	1
86	1001186	Label, Belt Replacement	1
87*	1001189	Wiring Diagram	1
88	2100247	Knob, Black Plastic	2
89	2100212	Handle, Pull, Snap-in	2
90	2120148	Spacer, Brass (Zinc Plated)	2
91*	0400138	Nut, Lock Conduit 1/2"	1
92	0400347	Strain Relief 1/2" Npt	1
93	0700482	Power Cord Assembly (Mfg. No. 9210825)	1
	0700577	Power Cord Assembly (Mfg. No. 9210826)	1
95*	1010905	Owner's Manual	1
96	7001188	Bun Chute Weldment	1
		<i>*Not Shown</i>	

WIRING DIAGRAM

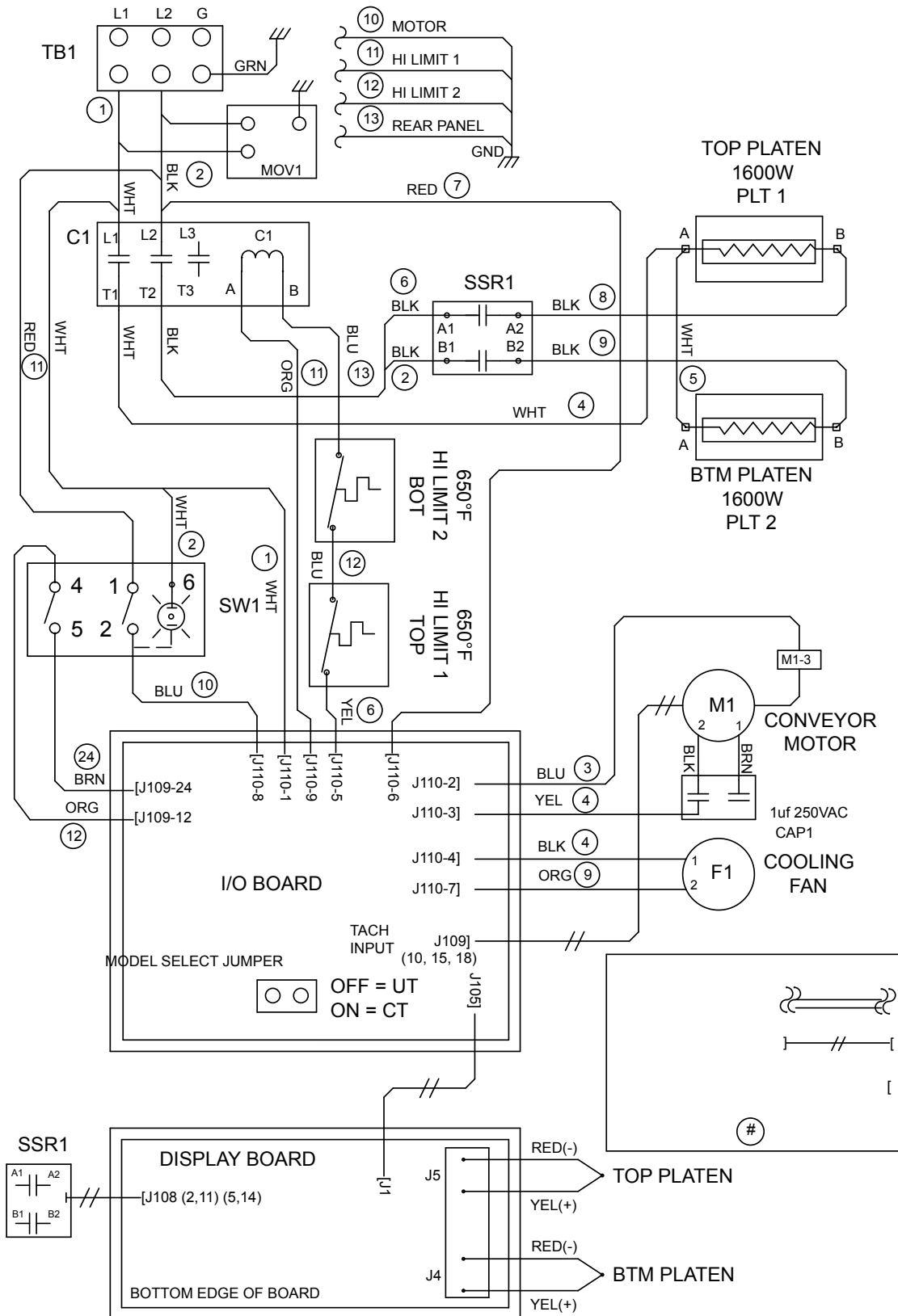



A.J. Antunes & Co.

We exist to make our customers successful.

A.J. Antunes & Co.
Headquarters/Manufacturing
Carol Stream, Illinois 60188 USA
Phone: (630) 784-1000
Toll Free: (800) 253-2991
Fax: (630) 784-1650

Antunes Equipment
Manufacturing (Suzhou) Ltd.,
Suzhou, Jiangsu, China 215011
Phone: 86-512-6841-3637
Toll Free: 400-0-7878-22
Fax: 86-512-6841-3907

www.ajantunes.com