

Place this manual in the Toaster section
of your Equipment Manual.

Manufactured exclusively for
McDONALD'S[®]

BY

ANTUNES

180 KEHOE BLVD.

CAROL STREAM, ILLINOIS 60188, U.S.A.

PHONE: +1-630-784-1000

TOLL FREE: +1-877-392-7854

FAX: +1-630-784-1650

www.antunes.com



Intertek



Intertek



HEBT-5V

Scan with mobile device or enter URL
for product and service information.

<http://tiny.cc/ajaHEBT5V>

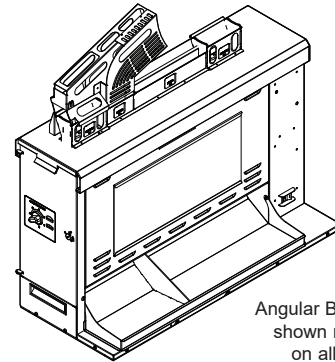

Angular Bun Feeder
shown not used
on all units.

Table of Contents

Owner Information.....	2	Language Selection	6
General	2	Operating Instructions	6
Service/Technical Assistance	2	Club Platen OFF units (Mfg. # 9210844 & 9200847)	7
Warranty Information	2	Programming	8
Specifications	3	Control Panel LEDs.....	8
Electrical Specifications & Plug Configuration	3	Settings	8
Pass Through Time	3	Adjusting Toast Quality.....	8
Dimensions	3	Factory Reset.....	8
Important Safety Information	4	Maintenance.....	9
Installation.....	5	Belt Inspection Information.....	9
Unpacking	5	Troubleshooting	11
Location.....	5	Replacement Parts	15
Operation.....	6	Wiring diagram	22

LIMITED WARRANTY

Antunes provides the following limited warranty to the original purchaser of all McDonald's Equipment.

All components are warranted against defects in the material and workmanship for a period of two (2) years. If any part becomes inoperable during the period of this warranty, Antunes will pay labor costs to an Authorized Service Agent to replace the part plus travel expenses.

WARRANTY EXCLUSIONS

- The cost of installation.
- Equipment that has been damaged due to shipment. Purchaser should make damage claim directly upon carrier.
- Alteration, misuse, abuse.
- Improper storage or handling.
- Improper maintenance.
- Failure to follow proper installation instructions, including electrical connection.

- Improper or unauthorized repairs.
- Scheduled Maintenance procedures as outlined in your MRC Card.
- Consumables such as Grill Covers (Release Sheets), gaskets, Conveyor Belt Wraps, O-rings, removal of links, and light bulbs.
- Freight, foreign, excise, municipal, or other sales or use taxes.
- Consequential damages such as loss of profit, loss of time, the cost of repairing or replacing other property which is damaged, or any other incidental damage of any kind.

Antunes reserves the right to make changes in design or add improvements on any products. The right is always reserved to modify Equipment because of factors beyond our control and government regulation. Changes to Equipment do not constitute a warranty charge.

This warranty is exclusive and is in lieu of all other warranties, expressed or implied, including any implied warranty of merchantability or fitness for a particular purpose, each of which is expressly disclaimed. The remedies described above are exclusive, and in no event shall or any of its Divisions be liable for special consequential or incidental damages for the breach or delay in the performance of this warranty.

This manual is for the exclusive use of licensees and employees of McDonald's Systems, Inc..

© McDonald's Corporation All Rights Reserved

HEBT-5V BUN TOASTER

Owner Information

General

This manual provides the safety, installation, and operating procedures for this unit. Please read this manual prior to installing and operating the unit.

This unit is manufactured from the finest materials available and assembled to our strict quality standards. This unit has been tested at the factory to ensure dependable trouble-free operation.

Service/Technical Assistance

If you experience any problems with the installation or operation of your unit, contact Antunes Technical Service at +1-877-392-7854 (toll free).

Warranty Information

Please read the full text of the Limited Warranty in this manual.

If the unit arrives damaged, contact the carrier immediately and file a damage claim with them. Save all packing materials when filing a claim. Freight damage claims are the responsibility of the purchaser and are not covered under warranty.

The warranty does NOT extend to:

- Damages caused in shipment or damage as result of improper use.
- Installation of electrical service.
- Normal maintenance as outlined in this manual.
- Malfunction resulting from improper maintenance.
- Damage caused by abuse or careless handling.
- Damage from moisture into electrical components.
- Damage from tampering with, removal of, or changing any preset control or safety device.

Fill in the information below and have it handy when calling Antunes Technical Service for assistance. The serial number is on the specification plate located on the rear of the unit.

Purchased From: _____

Date of Purchase: _____

Model No.: _____

Serial No.: _____

Mfg. No.: _____

Network ID Number: _____



Use only genuine Antunes replacement parts in this unit. Use of replacement parts other than those supplied by the manufacturer will void the warranty.

IMPORTANT! Keep these instructions for future reference. If the unit changes ownership, be sure this manual accompanies the equipment.

HEBT-5V BUN TOASTER

Specifications

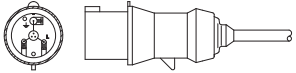
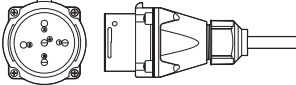
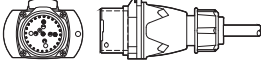
Electrical Specifications & Plug Configuration

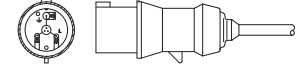
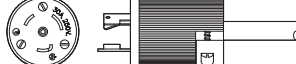
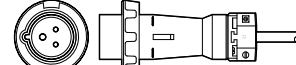
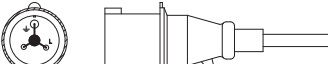
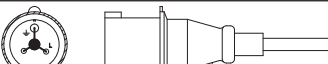
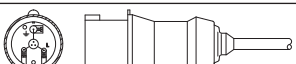
Model & Mfg. No	Volt	Watts	Hz.	Plug Description	Plug Configuration
9210840 (International)	230	4600	50/60	IEC-309 Pin & Sleeve, 32 Amp., 230 Volt	
9210841 (Australia)	220-240	4430-5250	50/60	Marechal 32 Amp., 220-250 Volt	
9210842 (New Zealand)	220-240	4430-5250	50/60	Marechal 32 Amp., 220-250 Volt	
9210843 (Taiwan)	230	4430-5250	50/60	L6-30P Twist-Lock 32 Amp., 220-250 Volt	
9210844 (Europe -Club Off)	220-240	4430-5250	50/60	IEC-309 Pin & Sleeve, 32 Amp., 230 Volt	
9210845 (Japan)	208	4600	50/60	L6-30P 30 Amp., 250 Volt, Straight Twist Lock	
9210846 (Domestic)	208	4800	50/60	Pin & Sleeve Plug 30 Amp., 250 VAC	
9210847 (Europe - Club Off)	230	3600	50/60	IEC-309 Pin & Sleeve 16 Amp., 220-250 Volt	
9210848 (Europe - Club On)	230	3600	50/60	IEC-309 Pin & Sleeve 16 Amp., 220-250 Volt	
9210849 (Korea)	230	4430-5250	50/60	IEC-309 Pin & Sleeve, 32 Amp., 230 Volt	

Pass Through Time

For all HEBT-5V units the pass through time is 22 seconds (+/- 2 seconds).

CAUTION

All electrical connections must be in accordance with local electrical codes and any other applicable codes.

Dimensions

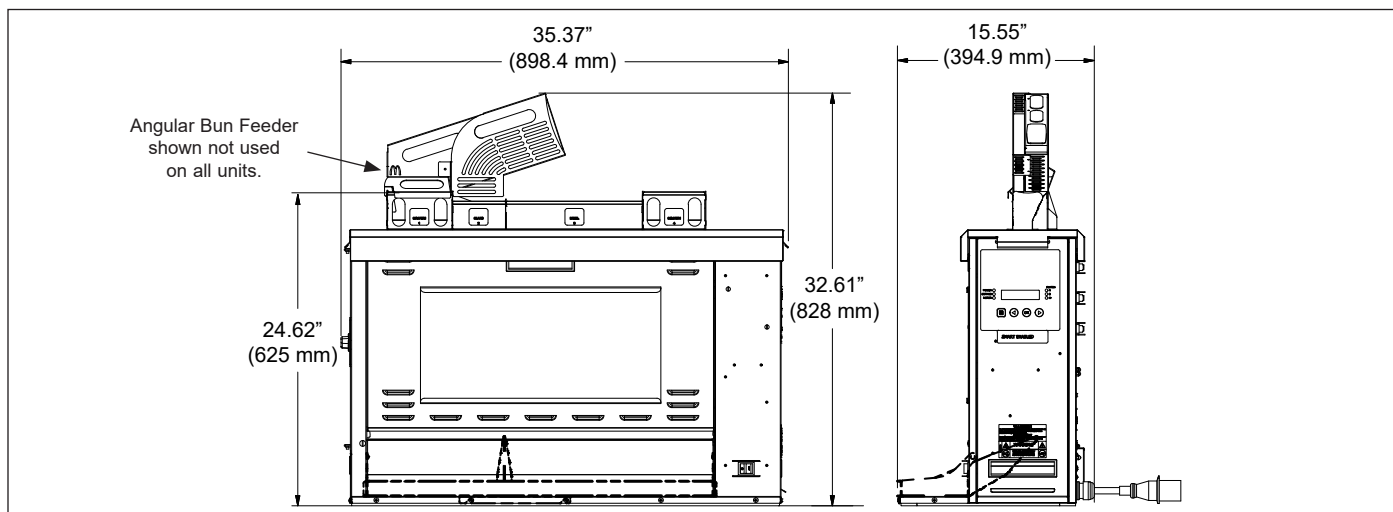

HEBT-5V BUN TOASTER

Important Safety Information

In addition to the warnings and cautions in this manual, use the following guidelines for safe operation of the unit.

- Read all instructions before using equipment.
- For your safety, the equipment is furnished with a properly grounded cord connector. Do NOT attempt to defeat the grounded connector.
- Install or locate the equipment only for its intended use as described in this manual. Do NOT use corrosive chemicals in and/or on this equipment.
- Do NOT operate this equipment if it has a damaged cord or plug, if it is not working properly, or if it has been damaged or dropped.
- This equipment should be serviced by qualified personnel only. Contact the nearest Authorized Service Agency for adjustment or repair.
- Do NOT block or cover any openings on the unit.
- Do NOT immerse cord or plug in water.
- Keep cord away from heated surfaces.
- Do NOT allow cord to hang over edge of table or counter.
- Do NOT clean this appliance with a water jet.

The following warnings and cautions appear throughout this manual and should be carefully observed.

- Turn the unit off, wait for the cool-down procedure to complete its cycle, and disconnect the power cord before performing any service or maintenance on the unit.

NOTE: Turning off the power switch does NOT turn off all power to the unit. When the unit is plugged in and turned off, an LED light flashes to indicate that the power cord is plugged in.

- The equipment should be grounded according to local electrical codes to prevent the possibility of electrical shock. It requires a grounded receptacle with separate electrical lines, protected by fuses or circuit breaker of the proper rating.
- Bread may burn. Therefore toasters must not be used near or below curtains or other combustible walls and materials. Failure to maintain safe operating distances may cause discoloration or combustion.

WARNING

To avoid possible personal injury and/or damage to the unit, all inspections, tests, and repair of electrical equipment should be performed by QUALIFIED SERVICE PERSONNEL. The unit MUST be completely shut down and unplugged before any internal servicing, except when electrical tests are required. Use extreme care during electrical circuit tests. Live circuits will be exposed.

CAUTION

All electrical connections must be in accordance with local electrical codes and any other applicable codes.

CAUTION

Bread may burn. Therefore toasters must not be used near or below curtains or other combustible walls and materials. Failure to maintain safe operating distances may cause discoloration or combustion.

CAUTION

NEVER unplug the power cord while the unit is running! Use the proper shutdown procedure before unplugging the power cord.

WARNING

**ELECTRICAL SHOCK HAZARD.
FAILURE TO FOLLOW THE INSTRUCTIONS IN
THIS MANUAL COULD RESULT IN
SERIOUS INJURY OR DEATH.**

- Electrical ground is required on this appliance.
- Do NOT modify the power supply cord plug. If it does not fit the outlet, have a proper outlet installed by a qualified electrician.
- Do NOT use an extension cord with this appliance.
- The toaster should be grounded according to local electrical codes to prevent the possibility of electrical shock. It requires a grounded receptacle with separate electrical lines, protected by fuses or circuit breaker of the proper rating.
- Check with a qualified electrician if you are unsure if the appliance is properly grounded.

HEBT-5V BUN TOASTER

Installation

Unpacking

1. Open the large box. It contains:
 - HEBT-5V toaster
 - Accessories box
2. Remove the accessories box from the large box.
3. With the help of another person, carefully remove the HEBT-5V from the large box.
4. Remove all protective coverings from the unit.
5. Open the Accessories Box. It contains:
 - Owner's Manual
 - Angular Bun Feeder (some models)
 - Bun Buffer Frame
 - Club/Heel Separator
6. Wipe the entire exterior of the toaster and the accessories mentioned above with a clean towel sprayed with a McDonald's approved sanitizer. Allow to air dry.

NOTE: Handle accessories with care. If an accessory becomes bent or damaged, it may not attach to the unit correctly, which may affect normal operation.

NOTE: If any parts are missing or damaged, contact Antunes Customer Service IMMEDIATELY at +1-877-392-7856 (toll free).

Location

When placing the toaster into service, pay attention to the following guidelines:

- Make sure power is off and the toaster is at room temperature.
 - Do NOT block or cover any openings on the unit.
 - Do NOT immerse cord or plug in water.
 - Keep cord away from heated surfaces.
 - Do NOT allow cord to hang over edge of table or counter.
1. Place the toaster in the required position designated by McDonald's.
 2. Attach the Bun Feeder, Angular Bun Feeder (if present), Bun Buffer Frame, and Crown\Heel Separator accessories (Figure 1).

NOTE: Be sure to attach the Bun Feeder so the tabs are seated properly. Failure to attach the Bun Feeder properly could cause serious damage to the toaster.

3. Plug the power cord into an appropriate power outlet. Refer to the specification plate for the proper voltage.

NOTE: See "Angular Bun Feeder (Some Models)" in the Operations section of this manual for information on using the supplementary Angular Bun Feeder (some models).

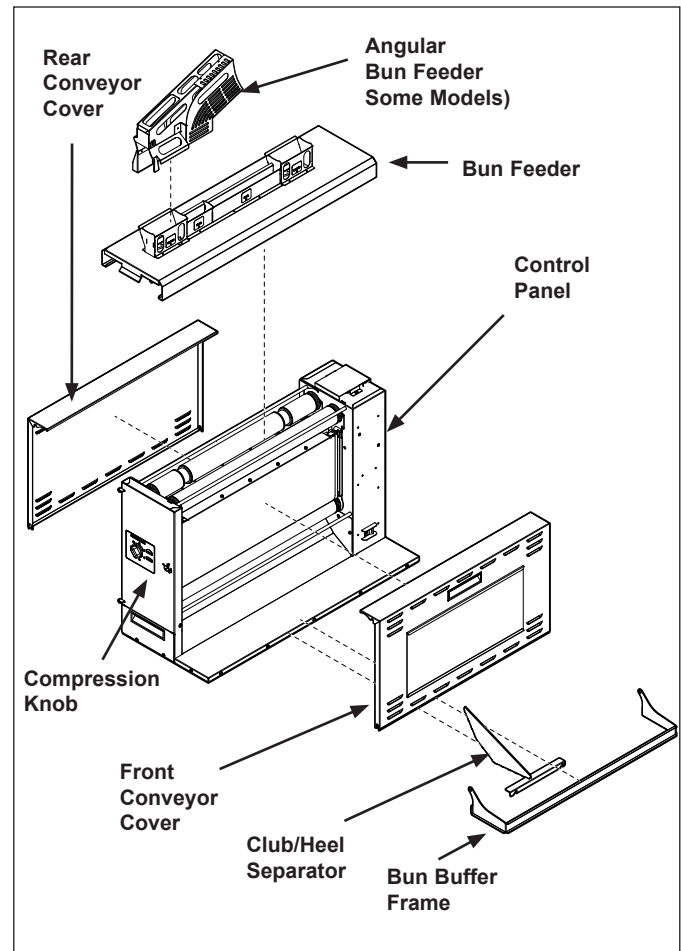

Figure 1. HEBT-5V Components
(Belts not Shown)

HEBT-5V BUN TOASTER

Operation

Language Selection

Follow these steps to set the language option for the HEBT-5V toaster.

1. Plug in the power cord and turn the toaster on.
2. See Figure 1. Press and hold the **MENU** button for five seconds.
3. Press the **LEFT ARROW** button five times so that the display shows "English".
4. Press the **OK** button.
5. Use the **LEFT** and **RIGHT ARROW** buttons to select your preferred language. The available languages appear in the following order:
 - English
 - Spanish
 - French Canadian
 - French
 - German
 - Portuguese
 - Italian
 - Swedish
 - Russian
 - Mandarin Chinese
 - Japanese
6. Press the **OK** button to save the changes.
7. Return the toaster to service.

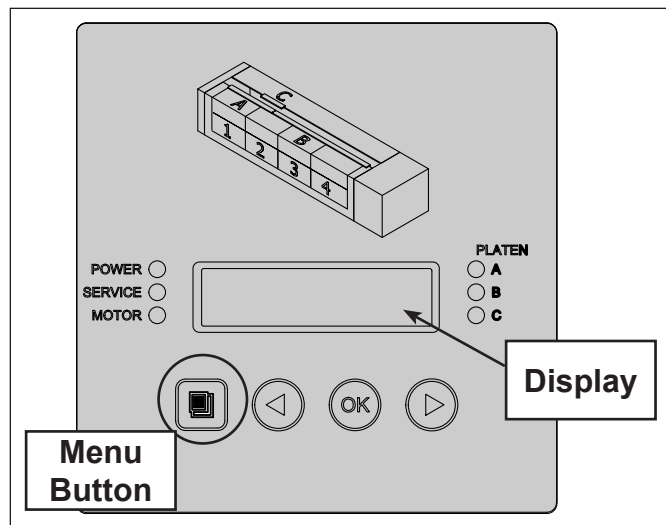

Figure 2. HEBT-5V Control Panel and Display

Operating Instructions

The HEBT-5V toasts Crowns, Heels, Clubs, and other products. Follow these steps to start the HEBT-5V:

1. Turn on the toaster and wait for warm-up to complete.
NOTE: The toaster fans turn on after the A, B, or C Platen temperature reaches 66° C (150° F).
2. Set the Compression Knob to 4 (recommended). If further adjustments are required see page 8 under Adjusting Toast Quality. Refer to the figure on page 8.
3. When the unit reaches operating temperature, the control panel displays "Ready".
4. Insert product into the designated area of the Bun Feeder Assembly or Angular Bun Feeder (if present) with the cut side of the bun facing towards the front. Toasted product drops into the Bun Buffer.

NOTE: For all HEBT-5V units, the product pass-through time is 22 seconds (+/- 2 seconds).

Angular Bun Feeder (some models)

The Angular Bun Feeder (not provided with some models) can be used to load buns during high volume times (Figure 3).

The Angular Bun Feeder can be used to load buns all from one side. Depending on the store setup, the Angular Bun Feeder may or may not be needed.

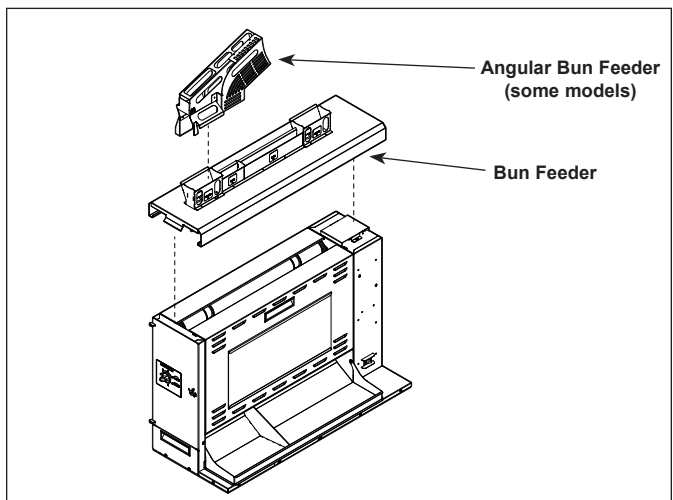

Figure 3. HEBT-5V Angular Bun Feeder (some models)

Operation (continued)

Club Platen OFF units (Mfg. # 9210844)

Units with Manufacturing Number 9210844 are shipped with the Club Platen off. Follow these steps to turn the Club Platen on:

NOTE: This applies **ONLY** to units with manufacturing numbers 9210844 & 9210847. All other units are shipped with the Club Platen turned on.

1. With the toaster on, press and hold both the **LEFT** and **RIGHT** arrow buttons for 5 seconds until **“Factory Settings Restored”** appears on the display (Figure 1).

NOTE: This sets the unit to display temperatures in degrees Celsius (°C).

2. The unit enters Cool Down mode.
3. Turn power switch off and then back on again.
4. The Club Platen is now operational. Allow the unit to warm up before using.
5. If you want the unit to display temperatures in degrees Fahrenheit:
 - a. Press and hold the **MENU** button for five seconds (Figure 5). The control panel displays “A Platen.”
 - b. Scroll to “Units” with the **LEFT** or **RIGHT** arrow buttons. Press the **OK** button
 - c. Scroll to “°F” (Fahrenheit) with the **LEFT** or **RIGHT** arrow buttons. Press the **OK** button.

NOTE: The “C Platen” remains active if the unit is reset to factory defaults at any time after performing these steps.

To turn the Club Platen Off:

NOTE: This applies only to units with manufacturing number 9210844.

1. Set the unit to display temperatures in degrees Fahrenheit (steps 1a and 1b). Press and hold the MENU button for five seconds (Figure 5). The control panel displays “A Platen.”
 - a. Scroll to “Units” with the **LEFT** or **RIGHT** arrow buttons. Press the **OK** button.
 - b. Scroll to “°F” (Fahrenheit) with the **LEFT** or **RIGHT** arrow buttons. Press the **OK** button.
2. Scroll to “C Platen” with the **LEFT** or **RIGHT** arrow buttons. Press the **OK** button.
3. Change the “C Platen” value to 0 °F (Fahrenheit) using the **LEFT** arrow button. Press the **OK** button.
4. To set the display back to degrees Celsius, scroll to “Units,” press the **OK** button, then scroll to “°C” (Celsius) and Press the **OK** button.

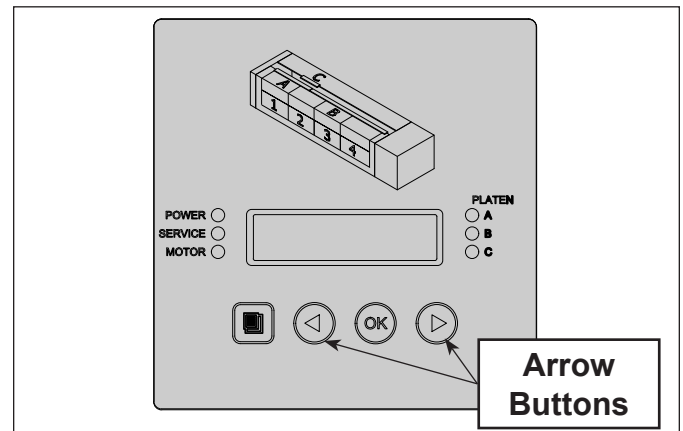

Figure 4. HEBT-5V Control Panel and Display

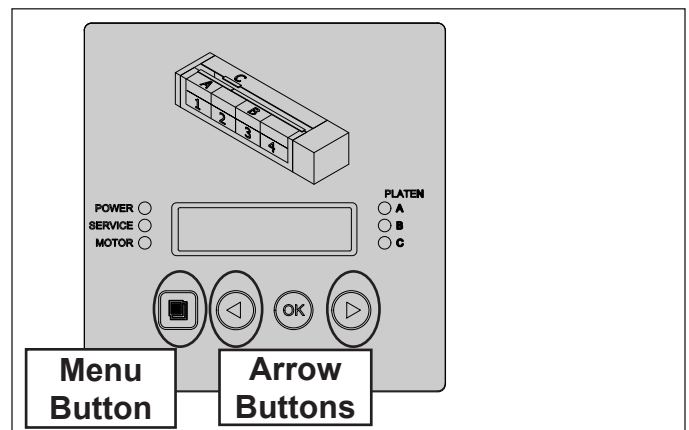

Figure 5. HEBT-5V Control Panel

HEBT-5V BUN TOASTER

Programming

Control Panel LEDs

The LEDs on the control panel light to signify when each item is operating. The Service LED lights and the corresponding LED (Motor, A Platen, B Platen, C Platen) blinks when the unit requires service. A message also appears on the display.

Settings

Follow these steps to view and adjust toaster settings:

1. When the unit is plugged in, press and hold the **MENU** button (Figure 5) for five seconds. The control panel displays "A Platen." The display scrolls to show the actual temperature, SSR Duty cycle, and the setpoint.
Example: **A Platen: 271°C 35% 271°C**

NOTE: The unit does not have to be turned on in order to access the settings menu.

2. Use the **LEFT** and **RIGHT** arrow buttons (Figure 4) to scroll through the settings, which appear in the following order:

- A Platen
- B Platen
- C Platen
- Units (°C/°F)
- Buzzer (Soft, Loud, Mute)
- Display Languages
- Serial Number
- Service Messages
- ET (Elapsed Time)
- Controls Temperature
- Motor

3. To change a setting, press the OK button and then use the **LEFT** and **RIGHT** arrow buttons to adjust as needed. Press the OK button again to save the changes. See Figure 4.

NOTE: The S/N (Serial Number), Elapsed Time, and Control Temperature can not be adjusted.

Adjusting Toast Quality

There are variations in bun products Worldwide that are used on the HEBT toaster such as moisture content, bun formulations, age, tolerances etc. The HEBT was designed to compensate for bun variations by allowing user to adjust the compression, light/dark (speed) & temperatures settings in order to achieve a Gold Standard toasted product.

1. **LIGHT DARK ADJUSTMENT:** Adjust the light dark setting with the **LEFT** or **RIGHT** arrow buttons. The default light/dark setting on the HEBT from the factory is 0 but can be adjusted from Lighter 0-10 to Darker 0-10. Light 10 is the lightest setting and dark 10 is the darkest. Each increase in "lighter" value will decrease the pass through time and each increase in "darker" value with increase the pass through time.
2. **TEMPERATURE ADJUSTMENT:** Adjust the set point temperature on the platens in the program menu. The default temperature settings on the HEBT are A Platen: 271°C (520°F) B Platen: 271°C (520°F) C Platen: 254°C (490°F). The temperatures can be increased to +/- 50°F (10°C) if needed to achieve an acceptable toast quality.

4. When the unit is turned on and ready, you can adjust the toast quality by pressing the **LEFT** and **RIGHT** arrow buttons on the control panel. After making an adjustment, test several products to verify they are toasting at the desired quality.

NOTE: This setting is maintained when the unit is powered off. If at any time the unit displays an error message or if it fails to operate properly, contact Antunes Technical Service immediately for service.

Factory Reset

To reset the unit to the factory default settings, press and hold the **LEFT** and **RIGHT** arrow buttons for 5 seconds until "Factory Settings Restored" appears on the display.

NOTE: For ALL Units, this sets the display temperature to °C (Celsius). Refer to the "Settings" section of this manual to change the display temperature to °F (Fahrenheit).

NOTE: For units with Mfg. No. 9210844, this turns the Club Platen on. To turn the Club Platen off, refer to the section titled "Club Platen OFF units with Mfg. No. 9210844" for information.

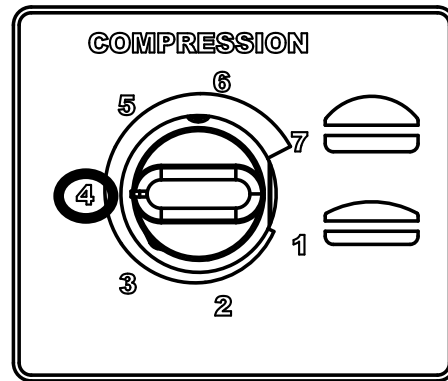

3. **COMPRESSION ADJUSTMENT:** Adjust the compression knob on the left side of the unit. The default compression setting on the HEBT is 4 but is adjustable from 1-7. It is acceptable to adjust the compression from 1-7 as needed to achieve the desired toast quality and bun compression.
4. **MOTOR SPEED ADJUSTMENT:** The recommended Motor setting value is 3300 which equals 22 seconds (+/- 2 seconds). With the unit plugged in, press and hold the 'Menu' button until the unit displays 'A Platen'. Press the **LEFT** arrow button. The display will show 'Motor' values. Press the **OK** button and the display will show the current motor setting. The default value is 4100. Use the **LEFT** arrow to change the motor setting to 3300. Once the motor is set to 3300, press OK to save the setting. Run a test bun through the toaster and use a stop watch to validate that the pass through time is 22 second ±2 seconds. If the bun takes longer than 24 seconds or less than 20 seconds to pass through the toaster then make the necessary adjustments to motor setting as described above to get within range.

Maintenance

Cleaning Instructions

All daily, quarterly, and annual Cleaning Instructions are included in Planned Maintenance document PR 32 included with this manual. Refer to that document for more information.

Belt Inspection Information

This section provides images and information related to inspecting Belt Wraps. The images are provided to help you determine when Belt Wraps are damaged and need to be replaced.

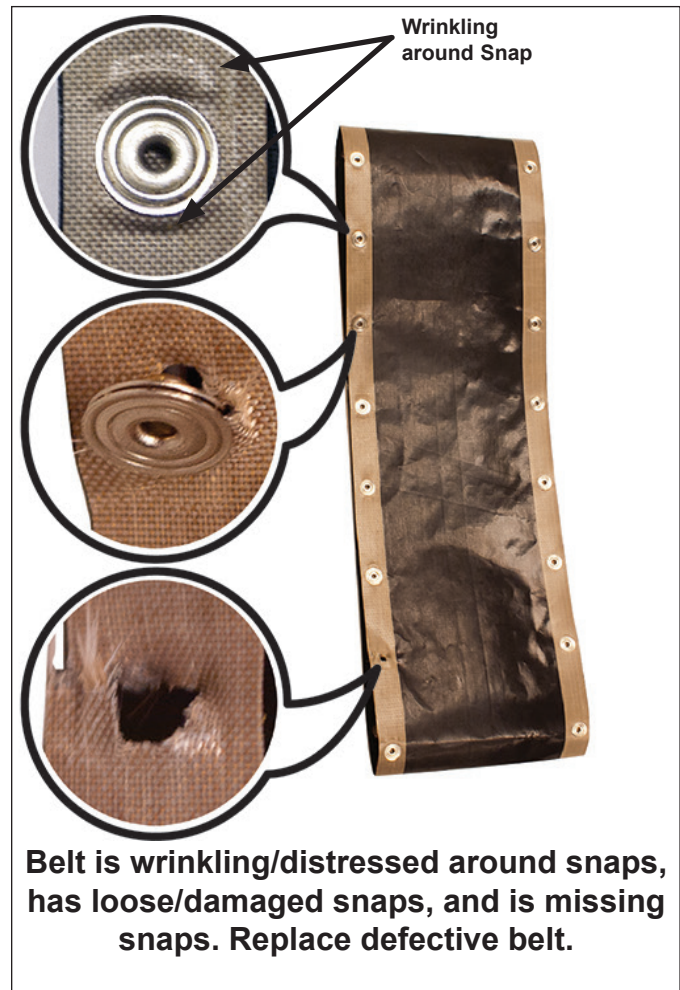
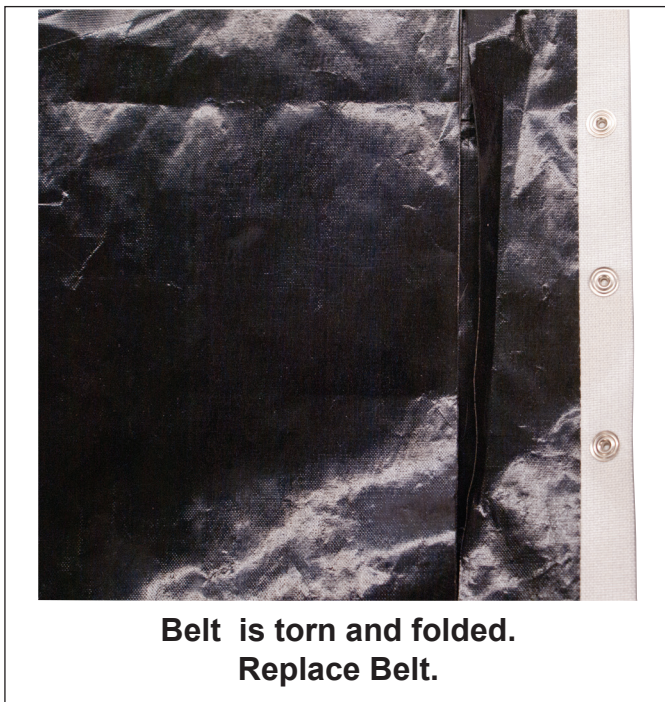

HEBT-5V BUN TOASTER

Maintenance (continued)

CORRECT BELT INSTALLATION

The belts are aligned vertically on the top and bottom rollers. The rollers are not visible when the belts are correctly positioned because the snaps are properly positioned.



INCORRECT BELT INSTALLATION.

The rollers are visible in the circled section. The belts are not aligned properly. Misaligned belts shift off the rollers to the left or right. In this image, the belts are shifted to the right and the snaps are not correctly positioned on the rollers. The belts are stretching which may result in torn belts or broken snaps.

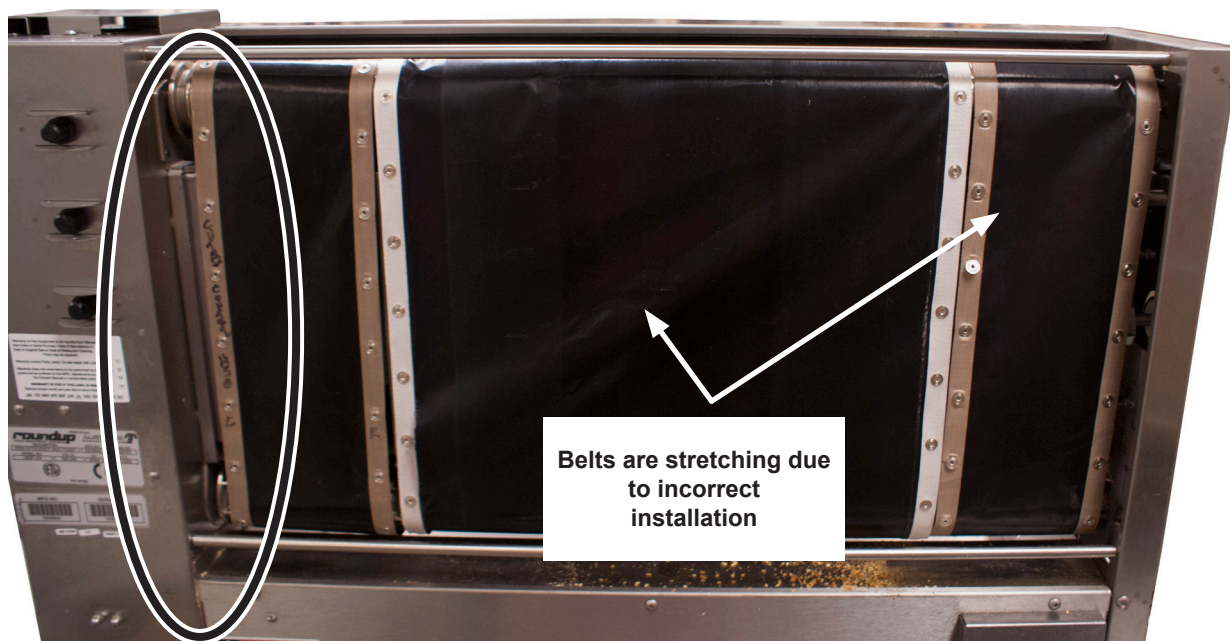

Troubleshooting

NOTE: This section covers Display Troubleshooting

WARNING

To avoid possible personal injury and/or damage to the unit, inspection, test and repair of electrical equipment should be performed by qualified service personnel. The unit should be unplugged when servicing, except when electrical tests are required.

If the troubleshooting steps listed do not solve your machine problem, contact an Authorized Service Agency for further assistance or service.

Problem	Possible Cause	Corrective Action
Unit displays error message: “SSR ‘A’ Fail. Toaster Shut Down” . Followed by a cool down cycle. Power, Motor, ‘B’, and ‘C’ lights are solid and Service and ‘A’ lights are flashing.	SSR is stuck closed causing platen ‘A’ temperature to exceed 343°C (650°F).	Cycle power off and on if fault message persist; contact your Maintenance person or Authorized Service Agency for service.
	Failed Display Board.	
	Failed I/O Board.	
Unit displays error message: “SSR ‘B’ Fail. Toaster Shut Down” . Followed by a cool down cycle. Power, Motor, ‘A’, and ‘C’ lights are solid and Service and ‘B’ lights are flashing.	SSR is stuck closed causing platen ‘B’ temperature to exceed 343°C (650°F).	Cycle power off and on if fault message persist; contact your Maintenance person or Authorized Service Agency for service.
	Failed Display Board.	
	Failed I/O Board.	
Unit displays error message: “SSR ‘C’ Fail. Toaster Shut Down” . Followed by a cool down cycle. Power, Motor, ‘A’, and ‘B’ lights are solid and Service and ‘C’ lights are flashing.	SSR is stuck closed causing platen ‘C’ temperature to exceed 343°C (650°F).	Cycle power off and on if fault message persist; contact your Maintenance person or Authorized Service Agency for service.
	Failed Display Board.	
	Failed I/O Board.	
Unit displays error message: “High Limit Tripped. Toaster Shut Down” . Followed by a cool down cycle.	Failed Platen Thermocouple causing the High Limit to trip.	Allow unit to cool and reset the High Limit. If the High Limit trips again, contact your Maintenance person or Authorized Service Agency for service.
	Defective High Limit	
Unit displays error message: “Conveyor Stopped. Toaster Shut Down” . Followed by a cool down cycle. Power, ‘A’, ‘B’, and ‘C’ lights are solid and Service and Motor lights are flashing.	Mechanical bind in one of the conveyors.	Cycle power off and on if fault message persist; contact your Maintenance person or Authorized Service Agency for service.
	Defective Motor	
	Damaged Ball Bearing(s).	
	Drive chain or sprockets are damaged.	
	Failed Display Board.	
	Failed I/O Board.	
Unit displays error message: “Internal Error. Power Plug: Out/In” .	Internal board error.	Turn unit off and unplug . Plug unit back in, Turn unit on and if error persists; contact your Maintenance person or Authorized Service Agency for service.
Unit displays error message: “Control Temperature Fail. Toaster Shut Down” . Followed by a cool down cycle. The control compartment’s ambient temperature is above 60°C (140°C).	Cooling Fan(s) are dirty and need to be cleaned.	Verify vents on toaster are unblocked and not near other heating appliances. Clean fans describe in the Maintenance section of this manual. If error persists contact your maintenance person or Authorized Service Agency for service.
	Failed Cooling Fan(s).	
	Failed Display Board.	
	Failed I/O Board.	

HEBT-5V BUN TOASTER

Troubleshooting (continued)

Problem	Possible Cause	Corrective Action
Unit displays fault message: “A’ System Fail” . Followed by a graphic display. Power, Motor, ‘B’, and ‘C’ lights are solid and Service and ‘A’ lights are flashing.	SSR is stuck open causing platen ‘A’ to not reach set point within 30 minutes.	Cycle power off and on if fault message persist; contact your Maintenance person or Authorized Service Agency for service.
	Failed Platen ‘A’ Heater.	
	Failed Display Board	
	Failed I/O Board.	
	Loose wire or connection.	
	Failed thermocouple.	
Unit displays fault message: “B’ System Fail” . Followed by a graphic display. Power, Motor, ‘A’, and ‘C’ lights are solid and Service and ‘B’ lights are flashing.	SSR is stuck open causing platen ‘B’ to not reach set point within 30 minutes.	Cycle power off and on if fault message persist; contact your Maintenance person or Authorized Service Agency for service.
	Failed Platen ‘B’ Heater.	
	Failed Display Board	
	Failed I/O Board.	
	Loose wire or connection.	
	Failed thermocouple.	
Unit displays fault message: “C’ System Fail” . Followed by a graphic display. Power, Motor, ‘A’, and ‘B’ lights are solid and Service and ‘C’ lights are flashing.	SSR is stuck open causing platen ‘C’ to not reach set point within 30 minutes.	Cycle power off and on if fault message persist; contact your Maintenance person or Authorized Service Agency for service.
	Failed Platen ‘C’ Heater.	
	Failed Display Board	
	Failed I/O Board.	
	Failed thermocouple.	
	Loose wire or connection.	
Unit displays fault message: “A’ Platen Low” . Followed by a graphic display. Power, Motor, ‘B’, and ‘C’ lights are solid and Service and ‘A’ lights are flashing.	SSR is stuck open causing platen ‘A’ temperature to decrease by 27° C (50° F) after achieving set point.	Cycle power off and on if fault message persist; contact your Maintenance person or Authorized Service Agency for service.
	Failed Platen ‘A’ Heater.	
	Failed Display Board	
	Failed I/O Board.	
	Loose wire or connection.	
	Failed thermocouple.	
Unit displays fault message: “B’ Platen Low” . Followed by a graphic display. Power, Motor, ‘A’, and ‘C’ lights are solid and Service and ‘B’ lights are flashing.	SSR is stuck open causing platen ‘B’ temperature to decrease by 27° C (50° F) after achieving set point.	Cycle power off and on if fault message persist; contact your Maintenance person or Authorized Service Agency for service.
	Failed Platen ‘B’ Heater.	
	Failed Display Board	
	Failed I/O Board.	
	Loose wire or connection.	
	Failed thermocouple.	

Troubleshooting (continued)

Problem	Possible Cause	Corrective Action
Unit displays fault message: “ C’ Platen Low ”. Followed by a graphic display. Power, Motor, ‘A’, and ‘B’ lights are solid and Service and ‘C’ lights are flashing.	SSR is stuck open causing platen ‘C’ temperature to decrease by 27° C (50° F) after achieving set point.	Cycle power off and on if fault message persist; contact your Maintenance person or Authorized Service Agency for service.
	Failed Platen ‘C’ Heater.	
	Failed Display Board	
	Failed I/O Board.	
	Failed thermocouple.	
	Loose wire or connection.	
Unit displays fault message: “ A’ Sensor Open ”. Followed by a graphic display. Power, Motor, ‘B’, and ‘C’ lights are solid and Service and ‘A’ lights are flashing.	Disconnected/Failed Platen ‘A’ Thermocouple.	Cycle power off and on if fault message persist; contact your Maintenance person or Authorized Service Agency for service.
	Failed Display Board.	
Unit displays fault message: “ B’ Sensor Open ”. Followed by a graphic display. Power, Motor, ‘A’, and ‘C’ lights are solid and Service and ‘B’ lights are flashing.	Disconnected/Failed Platen ‘B’ Thermocouple.	Cycle power off and on if fault message persist; contact your Maintenance person or Authorized Service Agency for service.
	Failed Display Board.	
Unit displays fault message: “ C’ Sensor Open ”. Followed by a graphic display. Power, Motor, ‘A’, and ‘B’ lights are solid and Service and ‘C’ lights are flashing.	Disconnected/Failed Platen ‘C’ Thermocouple.	Cycle power off and on if fault message persist; contact your Maintenance person or Authorized Service Agency for service.
	Failed Display Board.	
Unit displays fault message: “ Motor Running Slow. See Operators Manual ”. Power, ‘A’, ‘B’, and ‘C’ lights are solid and Service and ‘Motor’ lights are flashing.	Mechanical bind in one of the conveyors.	Cycle power off and on if fault message persist; contact your Maintenance person or Authorized Service Agency for service.
	Damaged Ball Bearing(s).	
	Drive chain or sprockets are damaged.	
	Defective Motor	
	Failed Display Board	
	Failed I/O Board.	
Unit displays: “ Display BD U2 ”, “ Display BD U4 ”, Display BD U6 ”, Display BD U7 ”, “ I/O BD U1 ”, “ I/O BD U2 ”, “ I/O BD U10 ”, “ Calibration Fault ”.	Internal board error.	Turn unit off and unplug. Plug unit back in. Turn unit back on. If error persists; contact your Maintenance person or Authorized Service Agency for service.

HEBT-5V BUN TOASTER

Troubleshooting (continued)

NOTE: This section covers Non-Error/Fault Display Troubleshooting

Problem	Possible Cause	Corrective Action
Buns not toasting adequately	Belts are worn or need cleaning (replace quarterly).	Inspect belts for cleanliness, worn spots, tears, or wrinkles. Clean or replace belts as described in Maintenance Card PR 32.
	One of the conveyor's top shafts is stuck in lower lock position.	Inspect position of the shafts as described in the Maintenance section of this manual.
	Either or both Upper/Lower Conveyor Locks are not properly locked in place.	Inspect the proper position of the Locks as described in Maintenance Card PR 32.
	Buns do not meet specifications.	Contact your bun supplier.
	Toaster Settings need to be adjusted.	Adjust toaster settings to match the toast quality specifications shown on page 8 of the Programming section of this manual.
Buns must be forced into the toaster. Buns Sticking and burning.	Belts are worn or need cleaning (replace quarterly).	Inspect belts for cleanliness, worn spots, tears, or wrinkles. Clean or replace belts as described in Maintenance Card PR 32.
	Chain and/or sprockets are worn and/or loose.	Contact your maintenance person or an Authorized Service Agency for service.
	Compression setting is incorrect.	Use recommended setting of 4. See the Programming section of this Manual if using a setting of 5.
	Buns are not inserted into the toaster properly.	Verify buns are being inserted into the designated area of the Bun Feeder Assembly with the cut side of the bun facing towards the front of the unit.
Toaster makes unusual sounds.	Compression setting is incorrect.	Use recommended setting of 4. See the Programming section of this Manual if using a setting of 5.
	Belts are installed incorrectly.	Belts must be installed as described in Maintenance Card PR 32.
	Belts are worn or need cleaning (replace quarterly).	Inspect belts for cleanliness, worn spots, tears, or wrinkles. Clean or replace belts as described in Maintenance Card PR 32.
	Motor Drive chain needs lubrication.	Lubricate the Drive Chain carefully with Lubit-8 (P/N 2140152) at least once a year.
	Bearing(s) are worn and/or binding.	Contact your maintenance person or an Authorized Service Agency for service.
Compression side door will not close.	Either or both Upper/Lower Conveyor Locks are not properly locked in place.	Inspect the proper position of the Locks as described in Maintenance Card PR 32.
Fan(s) are making an unusual sound.	Failed Cooling Fan(s).	Verify vents on toaster are unblocked and not near other heating appliances. Clean fans describe in Maintenance Card PR 32. If error persists contact your maintenance person or Authorized Service Agency for service.
	Cooling Fan(s) are dirty and need to be cleaned.	
Conveyor Belts not rotating.	One of the Conveyor's top shafts is stuck in lower lock position	Inspect position of the shafts as described in Maintenance Card PR 32.

Replacement Parts

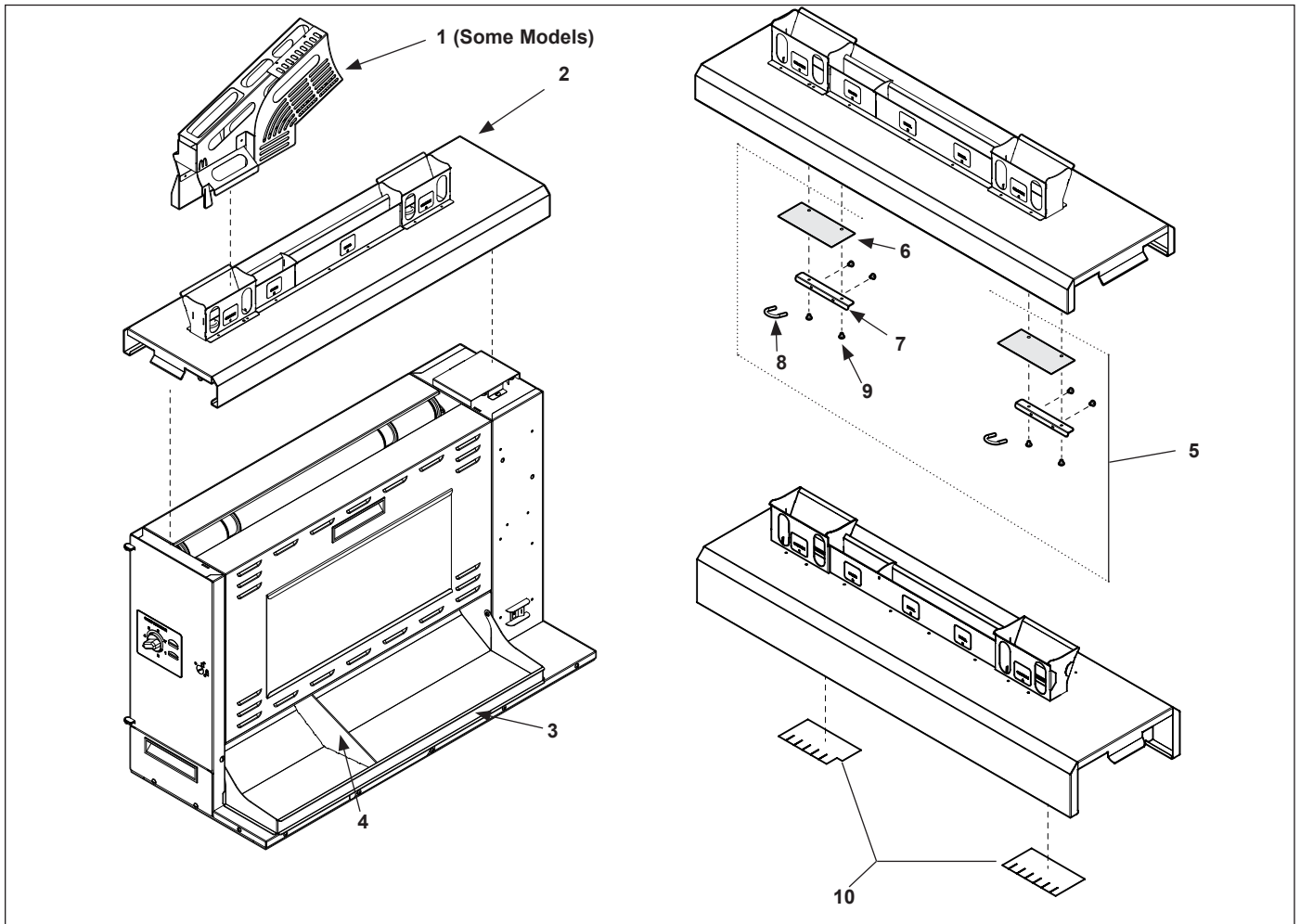

Item No.	Part #	Description	Qty
1	7001110	Angular Feeder Kit (Some Models)	1
2	7001189	Bun Feeder Assembly	1
3a	7001241	Bun Stop Bracket (w/out pins)	1
3b	7001082	Bun Stop Bracket (w/ pins)	
4	0021733	Club Base Divider Weldment	1
5	7000884	Damper Replacement Kit Incl. Items 6, 7, 8, & 9 (for Heat Shields with Damper Springs)	1
6	0400425	Damper	1
7	0506300	Damper Support	2
8	0600132	Spring, Damper Support	2
9	306P104	Screw, Mach. #06-32 x 1/4	8
10	7001400	Damper Replacement Kit (for Heat Shields without Damper Springs)	1

* Items available in packages of ten (10)

Optional Accessory

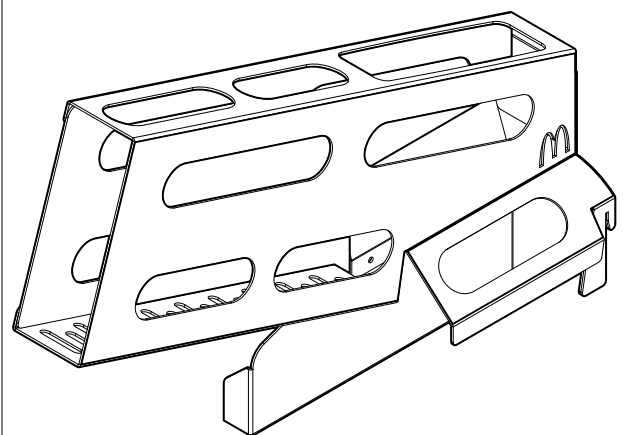

Angular Crown Feeder P/N 7000855

Available for stores with the primary prep on the left side of the unit.

HEBT-5V BUN TOASTER

Replacement Parts (continued)

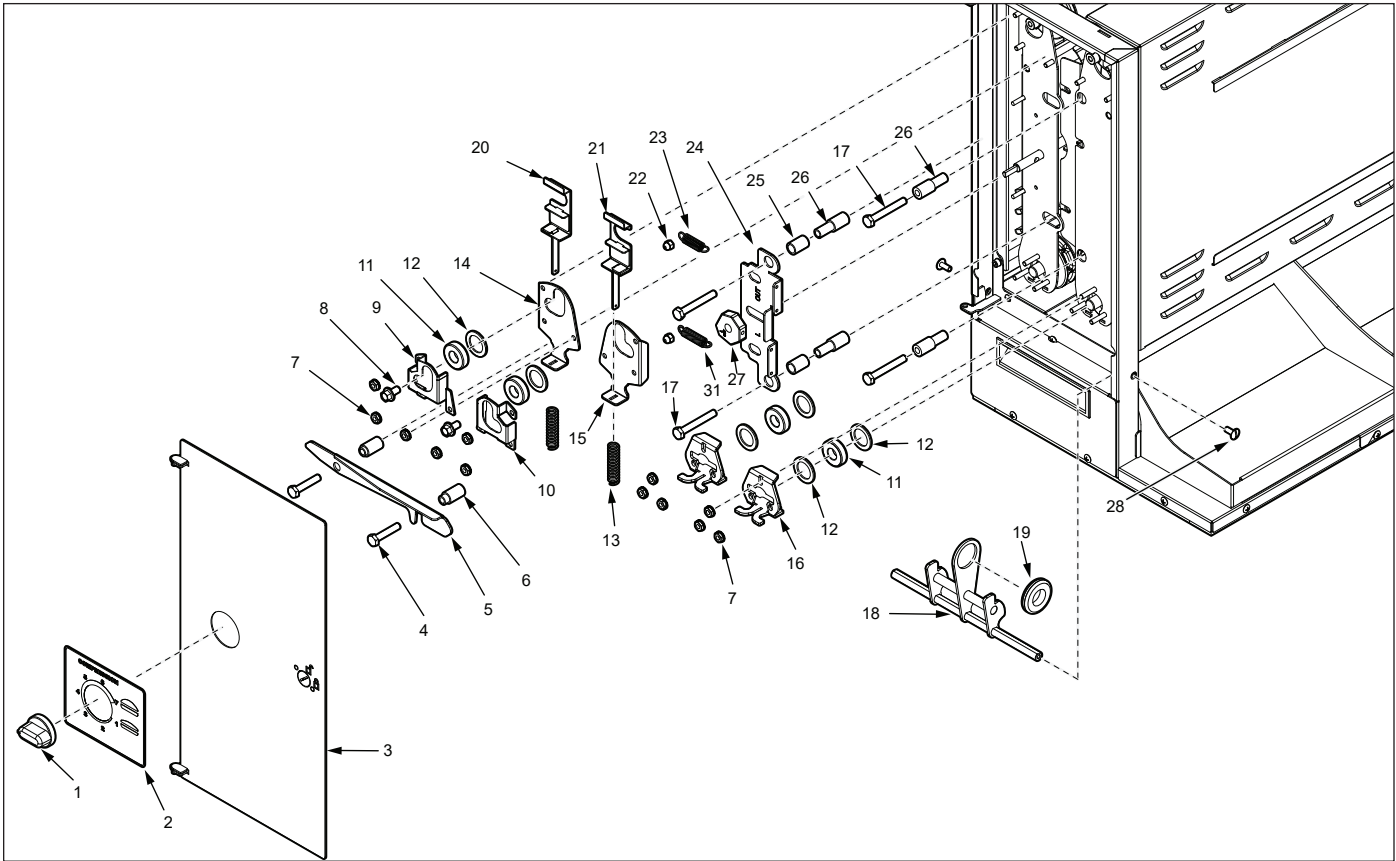

Item No.	Part #	Description	Qty
1	2100253	Knob, 1/4" Shaft, Push-On	1
2	1001417	Label, Compression	1
3	7001628	End Cover Assembly Kit	1
4	325P193*	Screw, Hex Head, #1/4-20 X 1.375"	1
5	0506188	Bracket, Housing Locking	1
6	2120216	Spacer, Upper Locking Plate, Front	1
7	310P146*	Nut, Hex 'KEPS' #10-32 (see Item 29, 30,, & 31)	1
8	325P176*	Screw, Flange Hex Head Cap (see item 30 & 31)	1
9	0506291	Bracket, Tensioner- End Housing, Rear (See item 31)	1
10	0506292	Bracket, Tensioner- End Housing, Front (see item 30)	1
11	2150285	Bearing, Single Groove S/S (See Item 29, 30 & 31)	8
12	0504320	Spacer 0.781 X 1.125 X 0.06" (see Item 29, 30 & 31)	10
13	0600158	Spring, Roller Tension (see item 30 & 31)	4
14	0506293	Plate, Tensioner - End Housing, Rear (see item 31)	1
15	0506294	Plate, Tensioner - End Housing, Front (See item 30)	1
16	0506167	Bracket, Bearing	2
17	325P194*	Screw, Hex Head, #1/4-20 X 2.00", S.S.	4

Item No.	Part #	Description	Qty
18	0021714	Weldment, End Housing Rod Support	1
19	0400418	Push In Grommet For 1-1/8" Dia. Hole	1
20	0021725	Weldment, Bearing Bracket & Spring Guide LH (see item 30)	1
21	0021724	Weldment, Bearing Bracket & Spring Guide RH (See item 30)	1
22	308P145*	Nut, Hex Acorn #08-32	9
23	0600156	Spring, Cam Adjustment	2
24	0012814	Cam Bracket & Thrust Strip Assembly, LH	1
25	2120223	Sleeve Bearing, .50" Od X .75" LG	2
26	2120213	Spacer, Frame & Platen LH	4
27	2150322	Cam, HEBT	2
28	310P110*	Screw, Mach. #10-32 X 1/2"	2
29	7000856	Bearing Kit (incl. items 7, 11, & 12)	1
30	7000859	Idler Shaft Tensioner Assy. Front End Hsg. Side Kit (Incl. items 7, 8, 10, 11, 12, 13, 15, & 21)	1
	7000860	Idler Shaft Tensioner Assy. Rear End Hsg. Side Kit (Incl. items 7, 8, 9, 11, 12, 13, 14, & 20)	1
31	0600143	Spring, Compression Setting	1

* Items available in packages of ten (10)

Replacement Parts (continued)

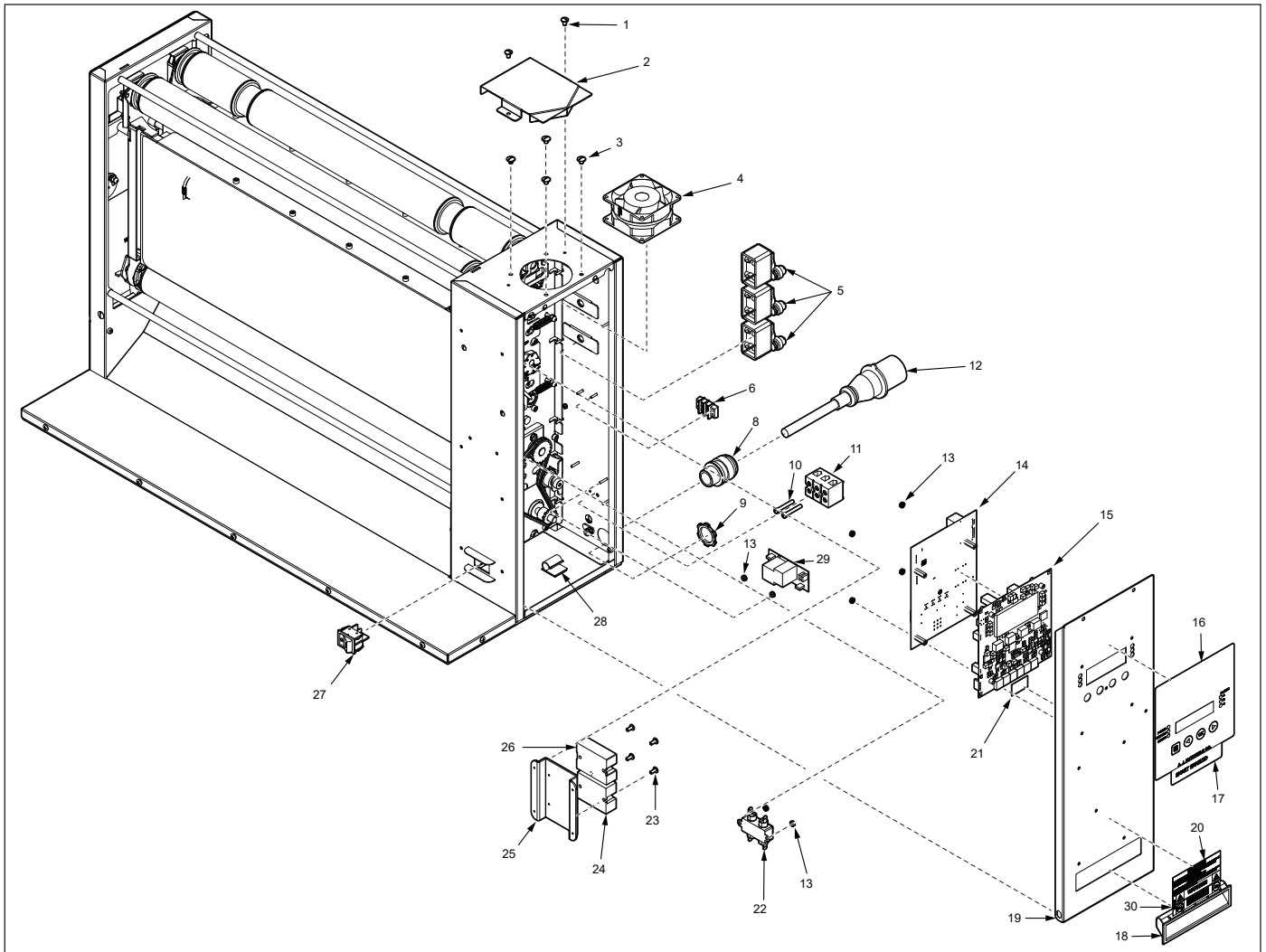

Item No.	Part #	Description	Qty
1	308P151*	Screw, SEMS #8-32 x 5/16"	1
2	0506155	Duct, Fan	1
	310P109	Screw, Mach #10-32 X 3/8 (Mfg. No. 9210840, 841, 842, 843, 844, 845, 846)	8
4	7000913	Fan Kit (Incl. Item 3)	1
5	4030352	Thermostat, Hi-Limit	3
6	4060387	Terminal Block, 2 Pole	1
7	306P105*	Screw, Mach #6-32 x 1/4	2
8	0400375	Strain Relief, Cord	1
9	0400376	Lock-nut, Conduit	1
10	308P193*	Screw, Mach #08-32 x 1 1/4	1
11	4060398	Terminal Block, S-Series	1
12	0700588	Power Cord (Mfg. No. 9210840, 844, & 849)	1
	7000465	Power Cord (Mfg. No. 9210845)	1
	0700687	Power Cord (Mfg. No. 9210841 & 842)	1
	7000463	Power Cord (Mfg. No. 9210846)	1
13	304P105*	Nut, Hex KEPS #4-40 Zinc	1
14	7000870	I/O Board Kit (Mfg. No. 9210840, 841, 842, 844, 845, 846, & 849)	1

Item No.	Part #	Description	Qty
15	7000869	Display Board Kit (Mfg. No 9210840, 841, 842, 844, 845, 846 & 849)	1
16	1001399	Label, Control	1
18	2100212	Handle, Pull, Snap-in	4
19	0506139	Control Panel	1
20	1001213	Label, Shock Hazard	1
21	1001434	Label, Thermocouple	1
22	2090163	Filter, RFI 250VAC	1
23	308P157*	Screw, Mach #06 x 3/80	15
24	4050240	Relay, Solid State Dual Pole With Conn-receptical	1
25	0506156	Heat Sink, Relay	1
26	7000370	Solid State Relay Kit	1
27	7000868	Switch Kit, Power	1
	4010285	Power Switch (Mfg. No. 9210849)	1
28	2110199	Clip "C" type	9
29	7000871	Varistor Board Kit	1
30	1000900	Label, Service	1

* Items available in packages of ten (10)

HEBT-5V BUN TOASTER

Replacement Parts (continued)

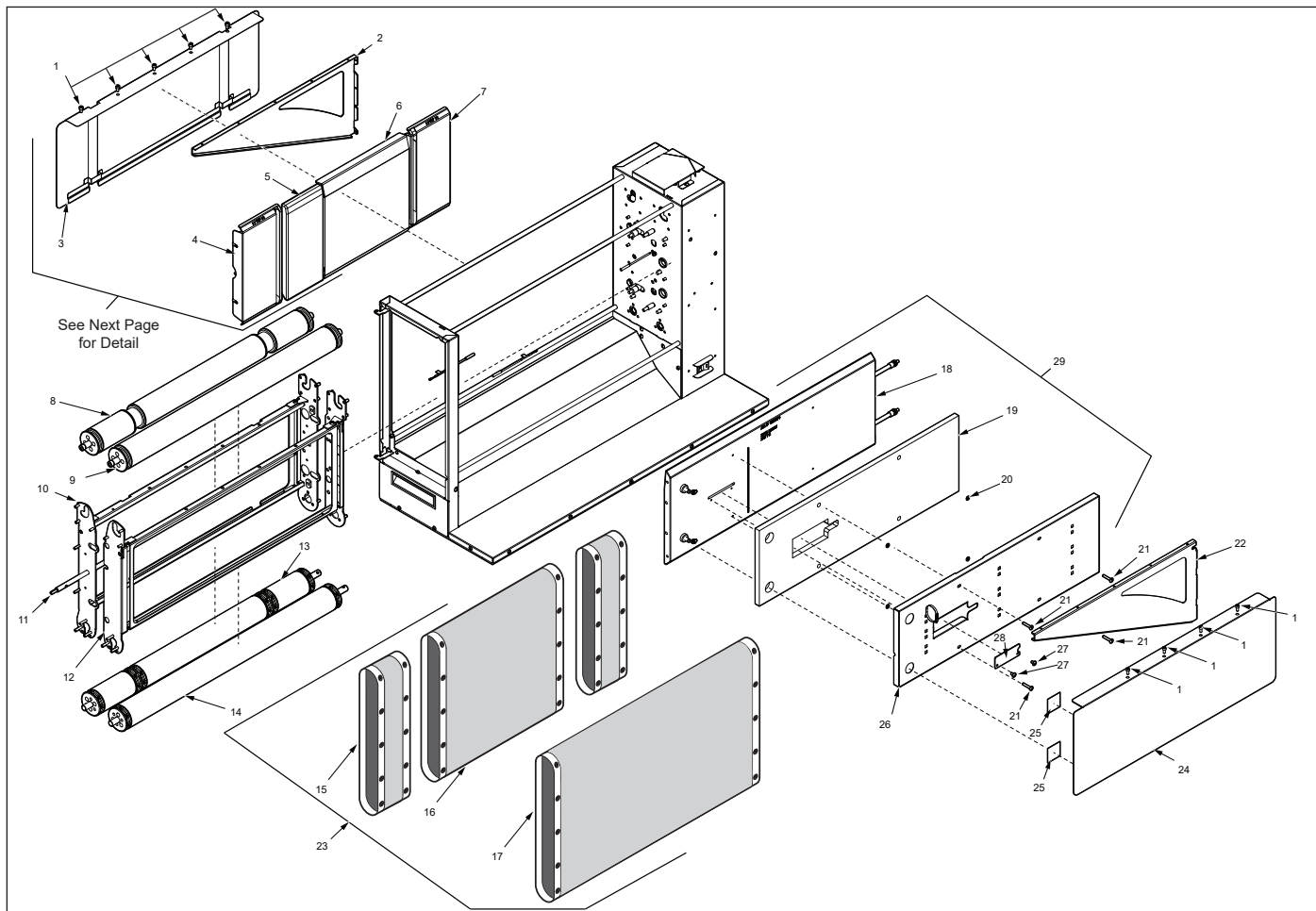

Item No.	Part #	Description	Qty
1	310P124*	Screw, #10-32 X 2-1/4" Truss Head S/S	1
2	0506093	Support Bracket, LH	1
3	0506149	Cover, Adj. Platen	1
4	0021780	Crown Plate Weldment End Housing Side	1
5	0100272	Platen, Club	1
6	0506178	Plate, Heel Platen	1
7	0506168	Plate, Crown	1
8	0021719	Weldment, Idler Roller Rear Top	1
9	0021718	Weldment, Idler Roller Front Top	1
10	0021707	Weldment, Adj. Platen Frame	1
11	2150303	Cam Shaft	1
12	0021711	Weldment, Fixed Platen Frame	1
13	0021721	Weldment, Drive Roller Rear Bottom	1
14	0021720	Weldment, Drive Roller Front Bottom	1
15	7000795	HEBT Crown Belt	1
16	7000797	HEBT Heel/Club Belt	1
17	7000796	HEBT Main Belt	1
18	0100266	Platen, Main (see Item 29)	1
19	0400416	Insulation, Main Platen (see Item 29)	1
20	308P102*	Washer, Int. Tooth #08 Steel Zinc Plated (see Item 29)	1

Item No.	Part #	Description	Qty
21	308P164*	Screw, Mach. #8-32 x 1" LG (see Item 29)	1
22	0506092	Support Bracket, RH	1
23	7000799	HEBT Belt Kit (incl. items 15, 16 & 17)	1
24	0506150	Cover, Fixed Platen	1
25	0400290	Insulator, Electrical	4
26	0506158	Insulation Plate	1
27	308P151*	Screw, SEMS #8-32 x 5/16" Flex Line (see Item 29)	1
28	0506183	Retainer Plate, Thermocouple (see Item 29)	1
29	7000857	Main Platen Kit (Mfg. No. 9210840, 841, 842, 844, & 849) Incl. Items 18, 19, 20, 21, 28, & 27)	1
	7000876	Main Platen Kit (Mfg. No. 9210845) Incl. Items 18, 19, 20, 21, 28, & 27)	1

* Items available in packages of ten (10)

Replacement Parts (continued)

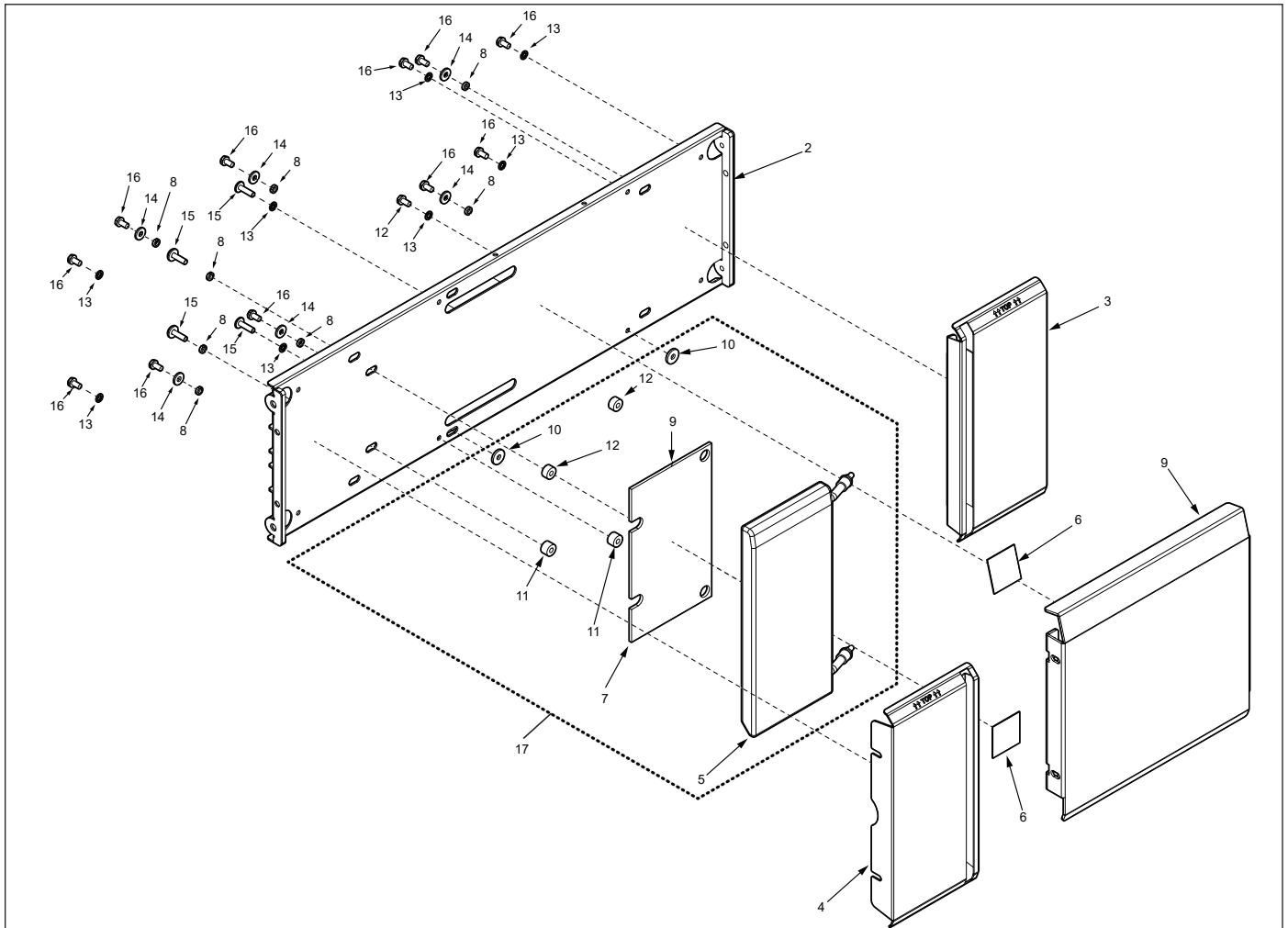

Item No.	Part #	Description	Qty
1	0012594	Adj. Platen Assembly	1
2	0021710	Weldment, Back Plate Adj. Platen	1
3	0021712	Weldment, Crown Plate	1
4	0021780	Crown Plate Weldment End Housing Side	1
5	0100271	Platen, Club 230 VAC, 900W (See Item 17)	1
6	0400290	Insulator, Electrical	1
7	0400417	Insulation, Fiberglass Club Platen (See Item 17)	1
8	0506083	Spacer	8
9	0506178	Plate, Heel Platen	1
10	0506198	Spacer, .625 OD x .218 x .075 Thick (See Item 17)	2
11	2120226	Spacer, .50 OD x .203 ID x .328 Thick (See Item 17)	2
12	2120227	Spacer, .50 OD x 203" ID x .265 Thick (See Item 17)	2
13	310P102*	Washer, Lock #10 S/S Internal Tooth (See Item 17)	1
14	310P140*	Washer, Flat #10 Stl/ZN .219 x .500 x .049 (See Item 17)	1

Item No.	Part #	Description	Qty
15	310P209*	Screw, Mach #10-24 x 3/4" Slotted TrussHD 18-8SS	1
16	310P214*	Screw, Hex #10-322 x 1/4 Thrd Cutting Type F, SS	1
17	7000858	Club Platen Assy. Kit (Mfg. No. 9210845) (Incl. Items 5, 7, 10, 11, 12, 13, & 14)	1
	7000875	Club Platen Assy. Kit (Mfg. No. 9210840, 841, 842, 844 & 849) (Incl. Items 5, 7, 10, 11, 12, 13, & 14)	1

* Items available in packages of ten (10)

HEBT-5V BUN TOASTER

Replacement Parts (continued)

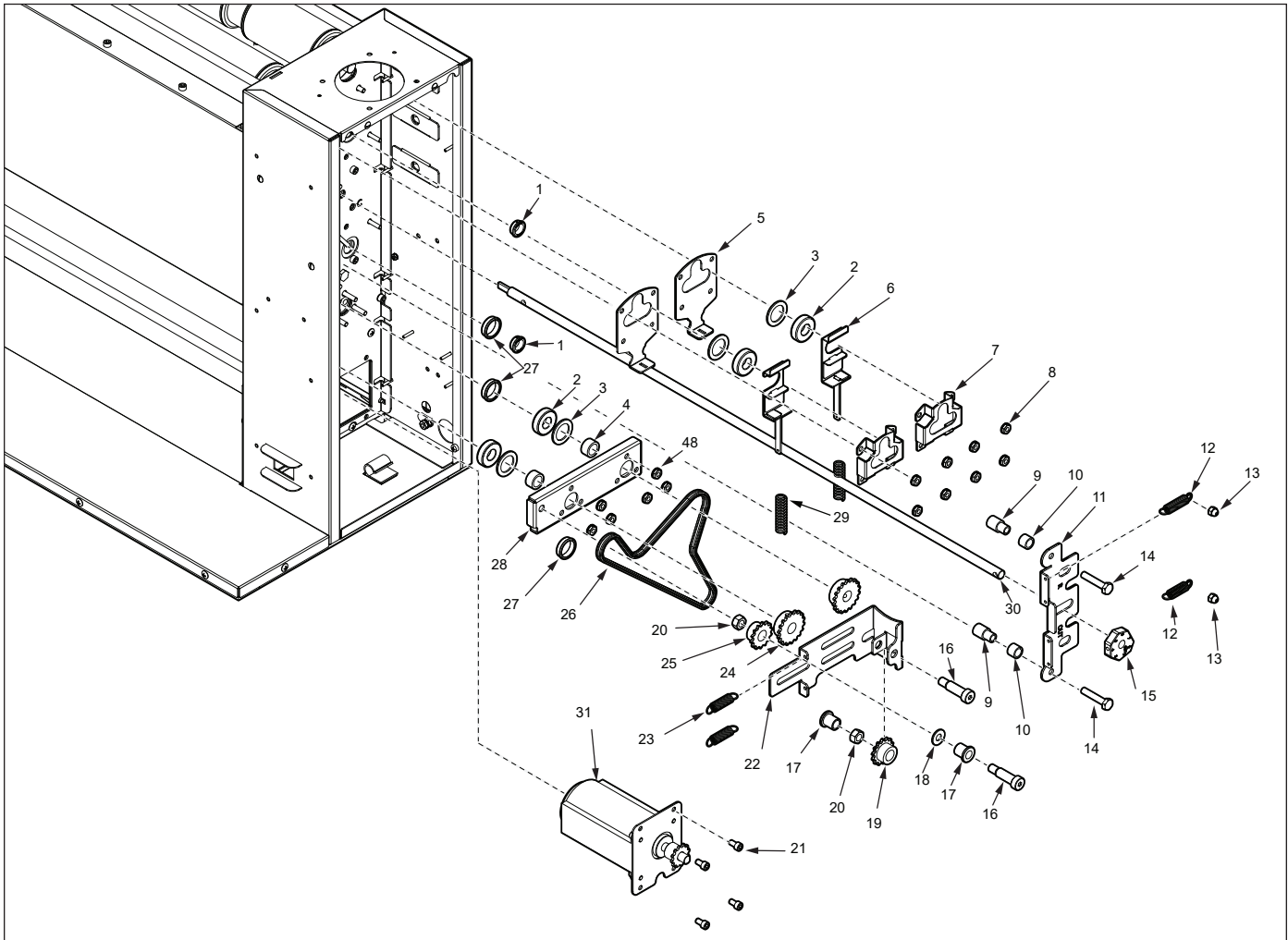

Item No.	Part #	Description	Qty
2	2150285	Bearing, Single Groove S/S (See Item 32)	8
3	0504320	Spacer (See Item 32)	10
4	2120221	Spacer, .69 x .503 x .359 S/S	2
5	0506144	Plate, Tensioner RH (See Item 32)	2
6	0021724	Weldment, Bearing Bracket-RH (See Item 32)	1
	0021725	Weldment, Bearing Bracket-LH (See Item 32)	1
7	0506163	Bracket Tensioner (See Item 32)	2
8	310P146*	Nut, Hex KEPS #10-32 (See Item 32)	1
9	2120214	Spacer, Adj. Frame RH	2
10	2120224	Sleeve Bearing	2
11	0506095	Cam Bracket, RH	1
12	0600143	Spring, Compression	2
13	308P145*	Nut, Hex Acorn #08-32	1
14	3250193	Screw, Hex Head, 1/4-20	1
15	2150322	Cam, HEBT	1
16	3310103	Shoulder Bolt	2
17	2150313	Flanged Bearing	2
18	212P118	Flat Washer Stainless Steel	1

Item No.	Part #	Description	Qty
19	2150312	Sprocket, 25B14	2
20	331P101*	Nut, Hex 5/16-18 Stl Zn	1
21	310P199*	Screw, #10-32 x 3/8 LG	1
22	0506185	Bracket, Chain	1
23	0600157	Spring, Chain Tension	2
24	2150185	Sprocket, 25B18 1/2" Bore	2
25	2150312	Sprocket, 25B14 (See Item 33)	2
26	2150324	Chain, Drive	1
28	0506146	Retainer, Idler	1
29	0600158	Spring, Roller Tension (See Item 32)	4
30	2150303	Cam Shaft	1
31	7000867	Drive Motor Kit	1
32	7000861	Idler Shaft Tensioner Kit (Incl. Items 2, 3, 5, 6, 7, 8, & 29)	1
33	7000872	Idler Sprocket Assy. Kit	1

* Items available in packages of ten (10)

Replacement Parts (continued)

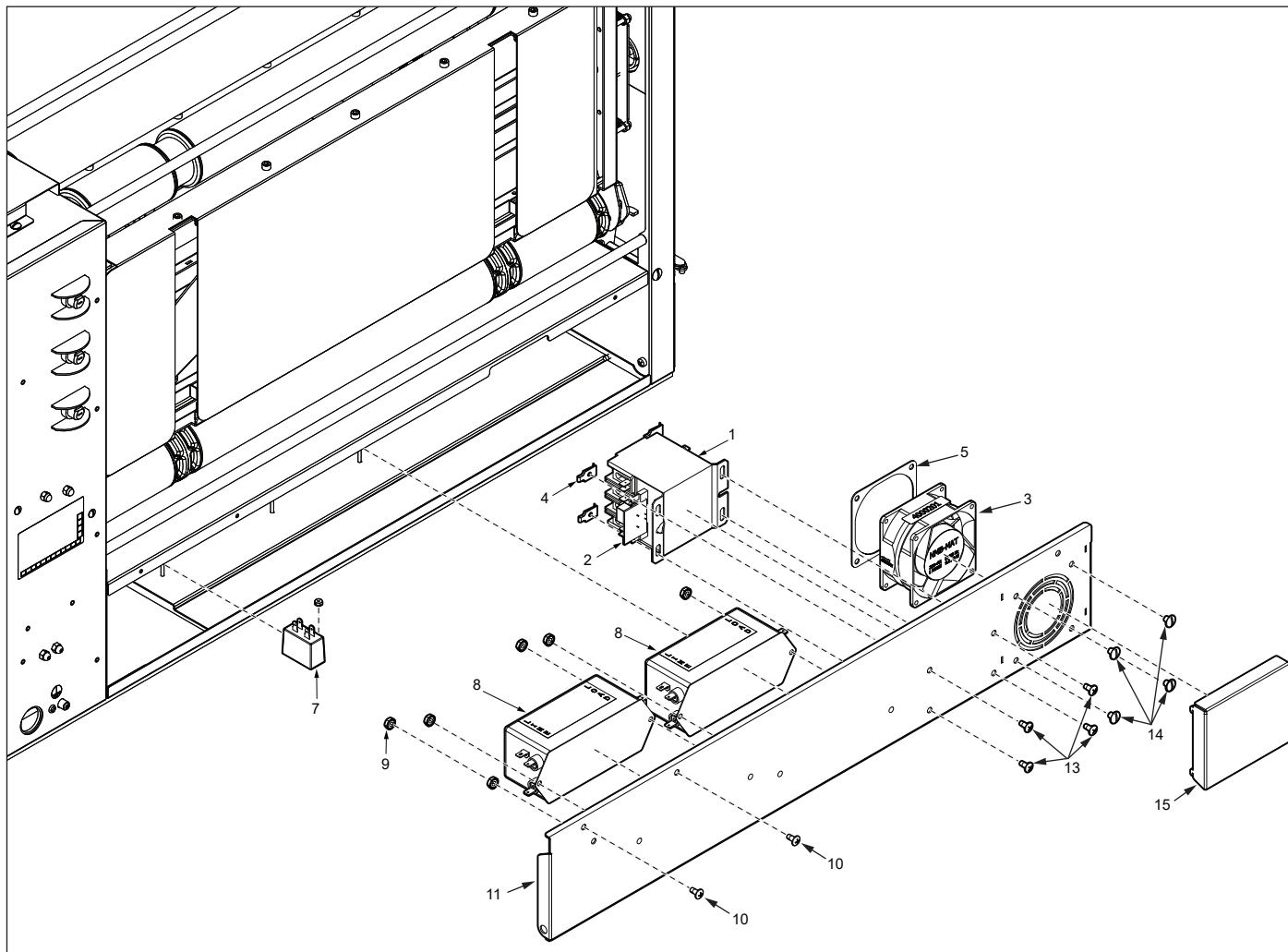

Item No.	Part #	Description	Qty
1	4050241	Contactors, 4 Pole	1
2	7000886	Snubber Board Kit	1
3	7000913	Fan - Axial, 200/230 VAC	1
4	300P102*	Nut, Speed #8-32 "U"	1
5	0508465	Fan Bracket (Mfg. No. 9210840, 841,842, 843, 844, 845, 846 Only)	1
6	304P105*	Nut, Hex KEPS #4-40 Zinc	1
7	4010221	Cap-MP, Motor Run	1
8	4050242	Filter, Power Line, 10A 120/250 V, 50-60 HZ	2
9	308P143	Nut, Hex KEPS #08-32	1
10	306P105	Screw-Mach., #6-32 x 1/2	2
11	0506181	Elec. Panel	1
12	308P124*	Screw, Mach #8-32 x 1/2"	1
13	308P157*	Screw, Tap #08-32 x 3/8	1
14	310P109*	Screw, Mach #10-32 x 3/8	4
15	0506170	Fan Cover	1

* Items available in packages of ten (10)

HEBT-5V BUN TOASTER

Wiring Diagram

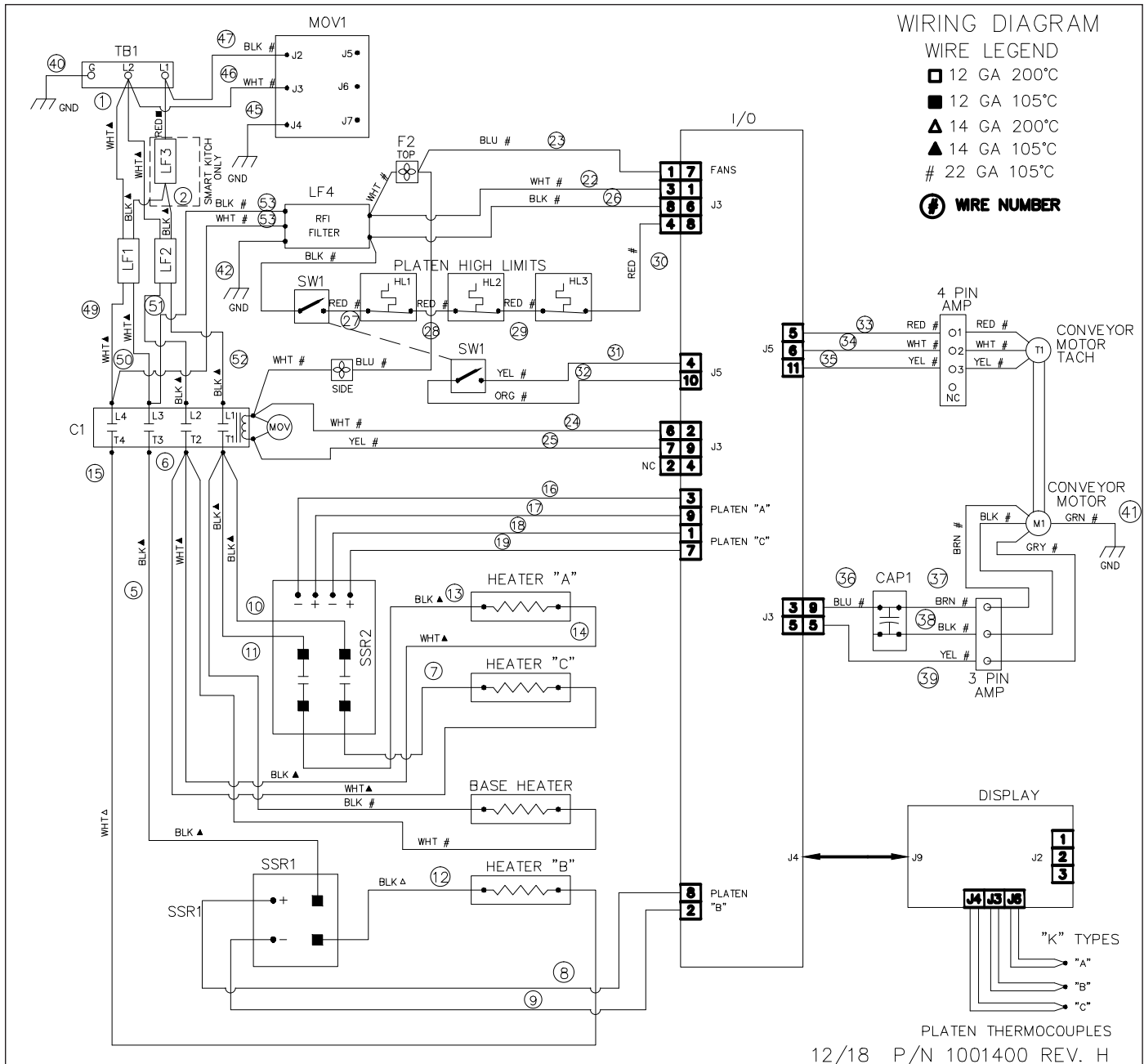



Corporate Headquarters
Carol Stream, IL, USA
Phone: +1.630.784.1000
Toll Free: +1.800.253.2991
Fax: + 1.(630).784-1650

China Facility
Suzhou, China
Phone: +84.512.6841.3637
Fax: +86.512.6841.3907

India Facility
Chennai, India
Phone: +91.44.25532212
Fax: +91.44.25532415