



Antunes



VCT Family

Scan with mobile device or enter URL for product and service information.

<http://tiny.cc/ajaVCT>

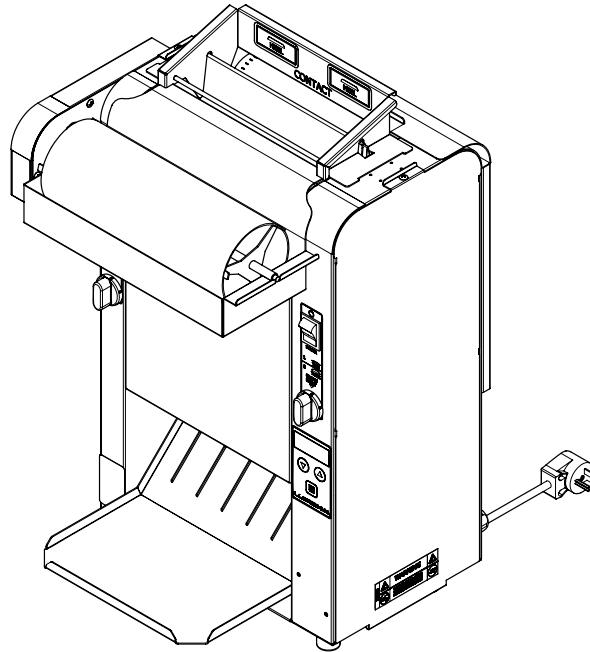

Vertical Contact Toaster

Model VCTM-2 Owner's Manual

Manufacturing Numbers:

9210910, 9210911



Original Instructions

www.antunes.com

CAUTION: Read all instructions before using the unit.

This manual is for the exclusive use of licensees and employees of
McDonald's Systems, Inc..

© McDonald's Corporation All Rights Reserved

P/N 1011373 Rev. D 11/20
McDonald's

Table of Contents

Overview	2
Before Use	2
In Case of Damage	2
Website	2
Service/Technical Assistance	2
In Case of Damage	2
Equipment Information to Save	2
Authorized Service Agency	2
Safety Information Page	3
Installation	3
Operation	3
Maintenance	3
Service	3
Specifications	4
Electrical Ratings	4
Electrical Cord & Configurations	4
Dimensions	4
Installation	5
Unpacking	5
Equipment Setup	5
Installing the Bun Chute	5
Operation	6
Recommended Temperatures	6
Recommended Speed Setting	6
Light/Dark Setting	6
Hi-Limit Reset Button	6
Viewing Settings	7
Changing Settings	7
Factory Reset	7
Maintenance	8
Daily Cleaning	8
Quarterly Cleaning	9
Replacing the Belt Wraps	10
Checking the Conveyor Belt Chains	11
Measuring conveyor belt Chains	11
Replacing Conveyor Belt Chains	11
Fault Codes	12
Troubleshooting	13
Replacement Parts	14
Exploded Views	16
Wiring Diagram	20
Notes	21
Limited Warranty	23

Overview

2 This unit is intended to be used for commercial applications, for example: in kitchens of restaurants, canteens, hospitals and in commercial enterprises such as bakeries, butcheries, etc., But not for continuous mass production of food.

Before Use

3 This manual contains safety, installation, and operating procedures for the unit.
3 Read and understand it completely before installing or operating the unit. Keep this document for reference. If the unit changes ownership, this manual must accompany it.

In Case of Damage

5 If the unit arrives damaged, file a claim with the carrier immediately. Save all packing materials when filing a claim. Freight damage claims are the responsibility of the purchaser and are not covered under warranty.

Website

www.antunes.com

Service/Technical Assistance

In Case of Damage

If any parts are missing or damaged, problems with the installation or operation of this product contact Antunes Customer Service immediately at +1-877-392-7856 (toll free).

Fill in the information in the next section and have it ready when calling for assistance. The serial number is on the specification sticker located on the system.

Equipment Information to Save

Purchased from:

Date of purchase:

Model number:

Serial number:

Manufacturing number:

Authorized Service Agency

Name:

Phone No:

Address:

Safety Information Page

Installation

- Read and understand all instructions before installing or using the unit.
- Install this unit to comply with the basic plumbing code of the Building Officials and Code Administrators, Inc. (BOCA) and the Food Service Sanitation Manual of the Food and Drug Administration (FDA).
- Install and locate the equipment only for its intended use as described in this manual.

WARNING

ELECTRICAL SHOCK HAZARD.
Failure to follow the instructions in this manual could result in serious injury or death.

Do not modify the power supply cord plug. If it does not fit the outlet, have a proper outlet installed by a qualified electrician.

Electrical ground is required on this appliance.

Check with a qualified electrician if you are unsure if the appliance is properly grounded.

Do NOT use an extension cord with this product.

The unit should be grounded according to local electrical codes to prevent the possibility of electrical shock. It requires a grounded receptacle with separate electrical lines, protected by fuses or circuit breaker of the proper rating.

NEVER unplug the power cord while the unit is running. Use the proper shutdown procedure before unplugging the power cord.

Operation

- The unit is furnished with a properly grounded cord connector. Do not attempt to defeat the grounded connector.
- Do not operate the unit if it has been damaged or dropped, if it has a damaged cord or plug, or if it is not working properly.
- Do not block or cover any openings on the equipment.
- Do not immerse the cord, unit, or plug in water.
- Keep the cord away from heated surfaces.
- Do not allow the cord to hang over the edge of a table or counter.
- This appliance is not to be used by persons (including children) with reduced physical, sensory or mental capabilities, or lack of experience and knowledge unless they have been given supervision or instruction.
- Children being supervised are not to play with the appliance.
- Bread may burn. Therefore toasters must not be used near or below curtains or other combustible walls and materials. Failure to maintain safe operating distances may cause discoloration or combustion.

Maintenance

- Do not use abrasive materials; they can damage the unit's stainless steel finish.
- Do not use corrosive chemicals in this equipment.
- Chlorides or phosphates in cleaning agents (e.g., bleach, sanitizers, degreasers, and detergents) can permanently damage stainless steel equipment. The damage is usually in the form of discoloration, dulling of the metal surface finish, pits, voids, holes, or cracks. This damage is permanent and is not covered by warranty.
- Always use a soft, damp cloth for cleaning. Rinse with clear water and wipe dry. When required, always rub in the direction of metal polish lines.
- Routine cleaning should be performed daily with soap and water.
- Rub off finger marks and smears using soap and water.
- Do not clean unit or components in a dishwasher unless specifically specified in the cleaning instructions.
- Do not clean the unit with a water jet or steam cleaner.

Service

- Inspection, testing, and repair of electrical equipment must be performed only by qualified service personnel.
- To avoid possible personal injury and/or damage to the unit, all inspections, tests, and repair of electrical equipment should be performed by qualified personnel ONLY. Contact Antunes Technical Service for adjustment or repair.
- Turn the power off, unplug the power cord, and allow unit to cool to room temperature before performing any service or maintenance.
- If the supply cord is damaged, it must be replaced by the manufacturer, its service agent, or a similarly qualified person in order to avoid an electrical hazard.
- Cleaning and user maintenance shall not be made by children without supervision.

Specifications

Electrical Ratings

Model & Mfg. No.	Volts	Watts	Amp	Hertz
VCTM-2 9210910 (No Butter Wheel)	208-230	3100	14.9/13.4	50/60
VCTM-2 9210911 (Butter Wheel)	208-230	3100	14.9/13.4	50/60

Electrical Cord & Configurations

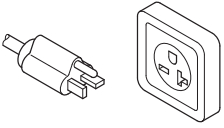
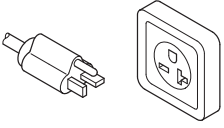
Model & Mfg. No.	Description	Configuration
VCTM-2 9210910 (No Butter Wheel)	NEMA 6-20P, 20 Amp., 250 VAC., Right Angle	
VCTM-2 9210911 (Butter Wheel)	NEMA 6-20P, 20 Amp., 250 VAC., Right Angle	

Dimensions

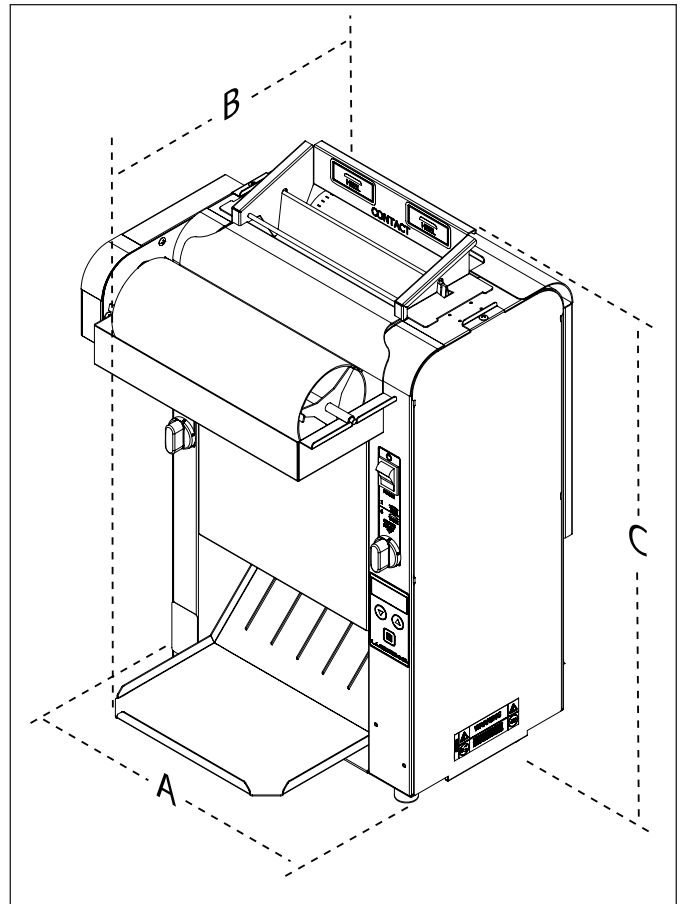

Model & Mfg. No.	Width (A)	Depth (B)	Height (C)
VCTM-2 9210910 (No Butter Wheel)	15 1/4" (387 mm)	15 1/2" (394 mm)	25 1/2" (648 mm)
VCTM-2 9210911 (Butter Wheel)	15 1/4" (387 mm)	15 1/2" (394 mm)	25 1/2" (648 mm)

Installation

Unpacking

1. Remove unit and all packing materials from shipping carton.

Open the included large box. It should contain the following (See Figure 2):

- Bun Chute
- Butter Wheel and Pan (Mfg. No. 9210911)
- Bun Feeder
- Two guttered Release Sheets
- Platen Cleaning Tool
- Owner's Manual
- Maintenance Card

2. Remove all shipping tape and protective coverings from the unit and parts.

NOTE: Missing or damaged parts? Contact Antunes Customer

Service at +1-877-392-7856 (toll free).

Equipment Setup

Before placing the toaster into service, pay attention to the following guidelines:

- Make sure power to the unit is off and the toaster is at room temperature.
- Do NOT block or cover any openings on the unit.
- Do NOT immerse cord or plug in water.
- Keep cord away from heated surfaces.
- Do NOT allow cord to hang over edge of table or counter.
- Connect the unit to the proper power supply. Refer to the specification plate for proper voltage.

NOTE: The factory has pre-installed a Release Sheet over the

Platen (Figure 2). Verify that it is properly in place before proceeding.

Installing Butter Wheel Assembly (Mfg. No. 9210911 ONLY)

1. Remove Butter Wheel and Pan from box.
2. Install the Pan over the front edge of the Heat Shield and place the Butter Roller in Pan and engage into gear case (Figure 2).
3. Fill the Butter Pan with Butter before toasting.

Installing the Bun Chute

1. If the unit is on, be sure to put on heat resistant gloves.
2. Insert the Bun Chute through the front of the unit according to Figure 1.
3. Hang the back of the Bun Chute on the rear Conveyor Cover hinge. When properly installed, the Bun Chute supports will be flush against the front of the unit (Figure 1).

NOTE: You may need to stand to the side of the unit to guide the Bun Chute into place from the front and rear using both hands.

IMPORTANT: Make sure Heat Shield assembly is activating the Conveyor Interlock Switch (Figure 2). The conveyors will not rotate unless the Heat Shield is in place and Conveyor Interlock Switch is activated.

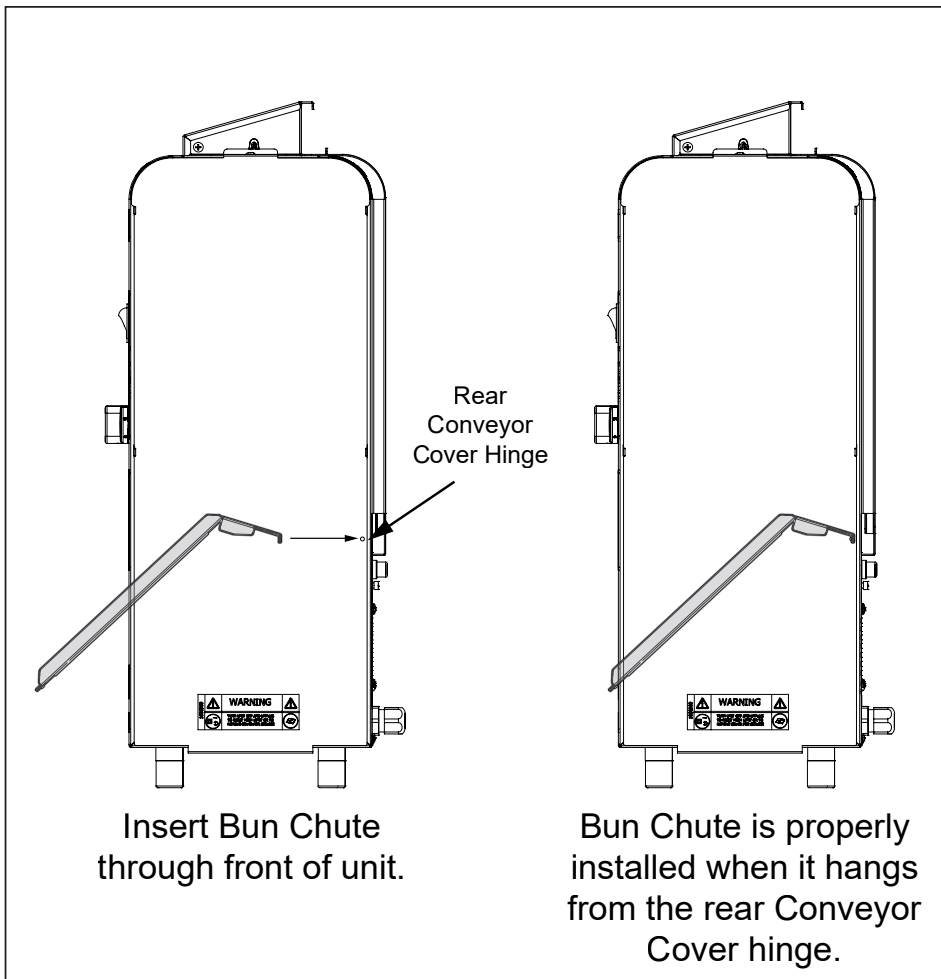

Figure 1. Bun Chute Installation

Installation

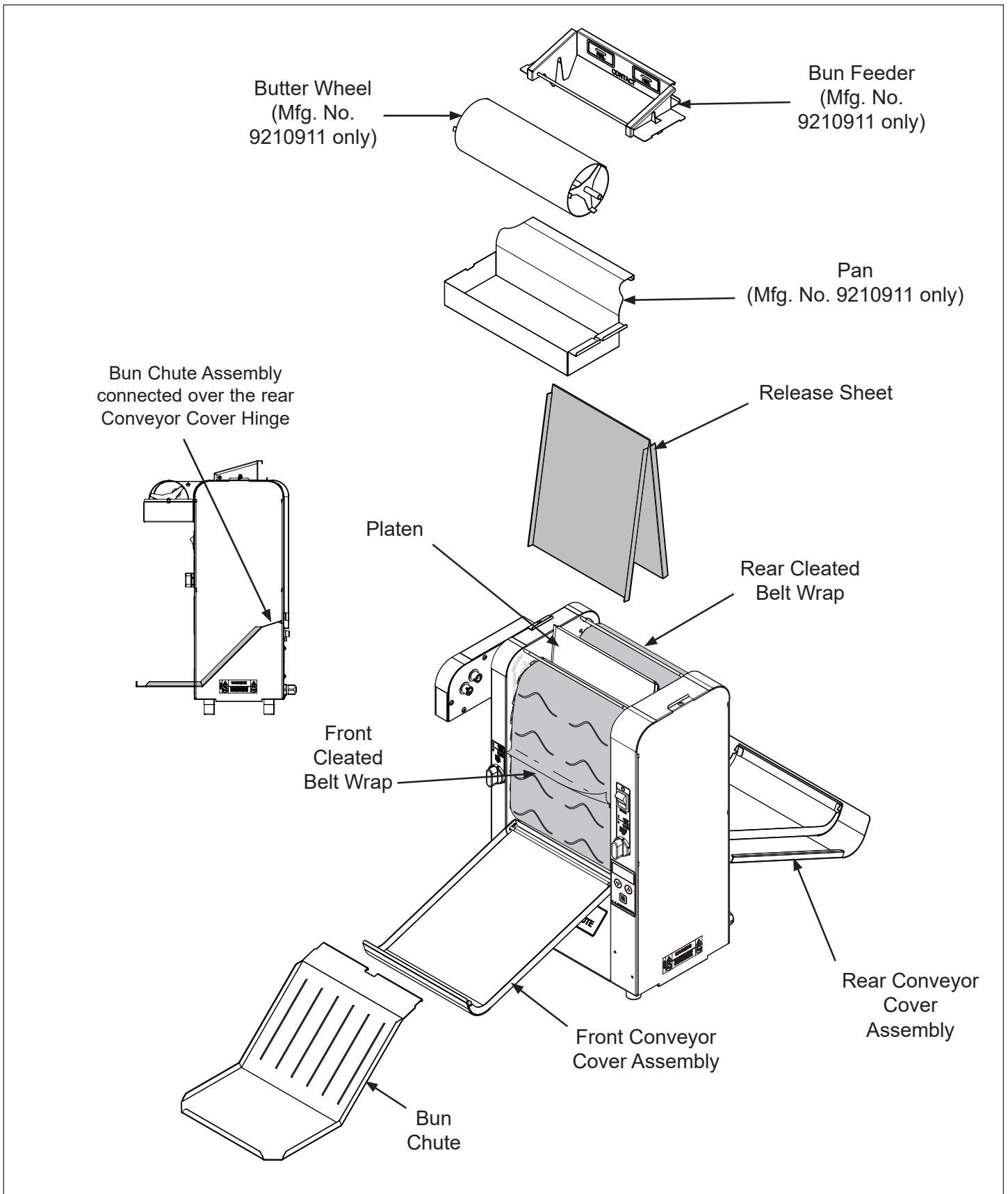

Figure 2. Components

Operation

1. Set the Bun Thickness Adjustment Controls (Figure 3).

NOTE: The McDonald's "Gold Standard" for toasting is the deciding factor on the finished product, not the Bun Thickness setting.

NOTE: The default Bun Thickness settings are 2 for Crown Front and 2 for Heel Rear, but settings are adjustable from 1-6. It is acceptable to adjust the Bun Thickness setting as needed to achieve the desired quality toast and bun compression.

2. Turn the power on and wait until the display reads USE before proceeding.

NOTE: The display (Figure 3) flashes "LO" during warm-up. "USE" appears when the toaster is ready for use.

3. Fill the Butter Pan (Mfg. No. 9210911 only).
4. Slide buns across the rotating Butter Wheel with the cut face down (Mfg. No. 9210911 only).
5. Drop buns into the Bun Feeder. Insert buns so they face the center platen. The cut sides of heel and crown must face each other and slide against the Release Sheet with Crowns inserted in the front and Heels inserted in the rear.
6. Toasted buns drop onto the Bun Chute (Figure 3).
7. Test at least 4 buns before putting the toaster into service.

Default Settings

Recommended Temperature and Speed

Refer to the table below Figure 3 for recommended settings.

Light/Dark Setting

The toaster has a Light/Dark adjustment setting that allows you to adjust the toast quality as the toaster is running.

While the toaster is in USE mode, press the UP or Down arrow buttons to adjust the Light/Dark setting.

The default setting is D0.

Light 10 is the lightest setting

Dark 10 is the darkest setting.

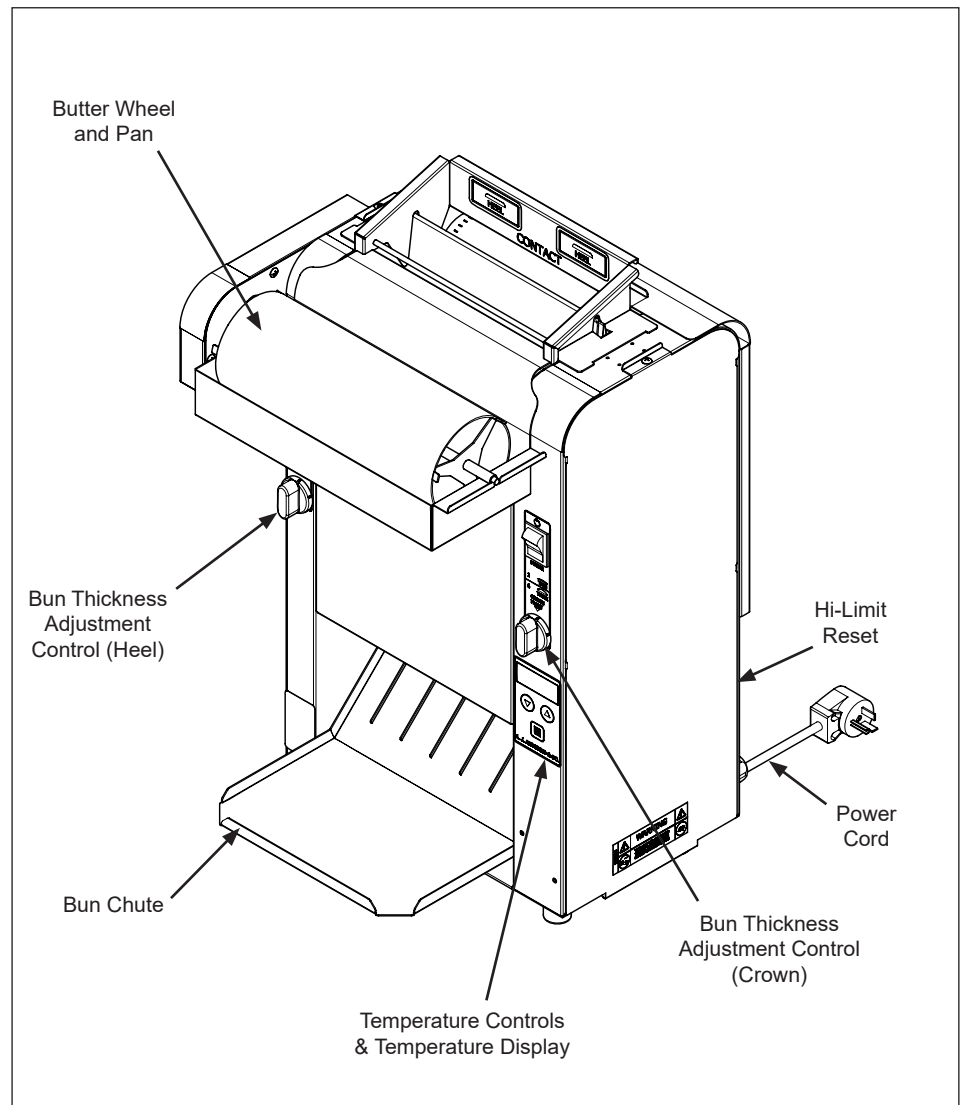

Figure 3. VCTM-2 Toaster

Mfg. No.	Platen A Setting	Platen B Setting	Speed Setting	Pass Through Time
9210910 (No Butter Wheel)	293° C (560° F)	218° C (424° F)	255	22 seconds
9210911 (Butter Wheel)	252° C (486° F)	257° C (495° F)	140	40 seconds

Viewing Settings

To view the toaster settings press and hold the Menu button (Figure 4) for approximately 5 seconds. The unit beeps and shows the settings in the following order, displaying the value in column 1 first, then the actual setting.

Display Shows	Setting Description
°A - ° F	Platen current temperature*
b° - ° F	B Auxiliary heater current temperature*
SPEd	Speed of belts
Unit	Current temperature Unit
Er	Error Code
Et - d	Elapsed Time of toaster usage
Int ° F	Internal toaster Temperature
PL	Power Line Voltage

* The first circles shown in these values represent the Platen indicator lights. The temperature unit will be shown as ° F or ° C depending on the Unit setting.

Changing Settings

The only settings that can be changed on the toaster are:

- Platen setpoint temperature
- Auxiliary setpoint temperature
- Speed
- Unit

To change these settings:

1. With the toaster turned off, press and hold the Menu button and turn the toaster on. Continue holding the Menu button until the unit beeps and EnA appears on the display. Release the Menu button.
2. Press the Menu button again. The toaster shows °A - ° F (Platen) and then shows the current Platen setpoint value. Use the ▲ and ▼ buttons to change the value as needed.
3. Press the Menu button to move to the Auxiliary setting. Edit as needed.
4. Press the Menu button to move to the SPEd (Speed setting). Edit as needed.
5. Press the Menu button to move to the Unit setting. Edit as needed.

The settings are saved each time you press the Menu button and move to the next value. The toaster exits programming mode after 30 seconds of inactivity.

Factory Reset

To reset the toaster to the original factory settings:

6. Turn the toaster off.
7. Press and hold both the ▲ and ▼ buttons and turn the toaster on, continuing to hold the ▲ and ▼ buttons until the unit beeps and FR (Factory Reset) appears on the display.
8. Release the buttons.

Hi-Limit Reset Button

A Hi-Limit Control turns off power to the unit if it overheats. To reset the control, allow the unit to cool, then locate the Reset Button at the rear of the unit. Remove the black protective cap, press the Reset Button, and reinstall the protective cap (Figure 3).

NOTE: If the Hi-Limit requires continuous resetting, contact Antunes Technical Service.

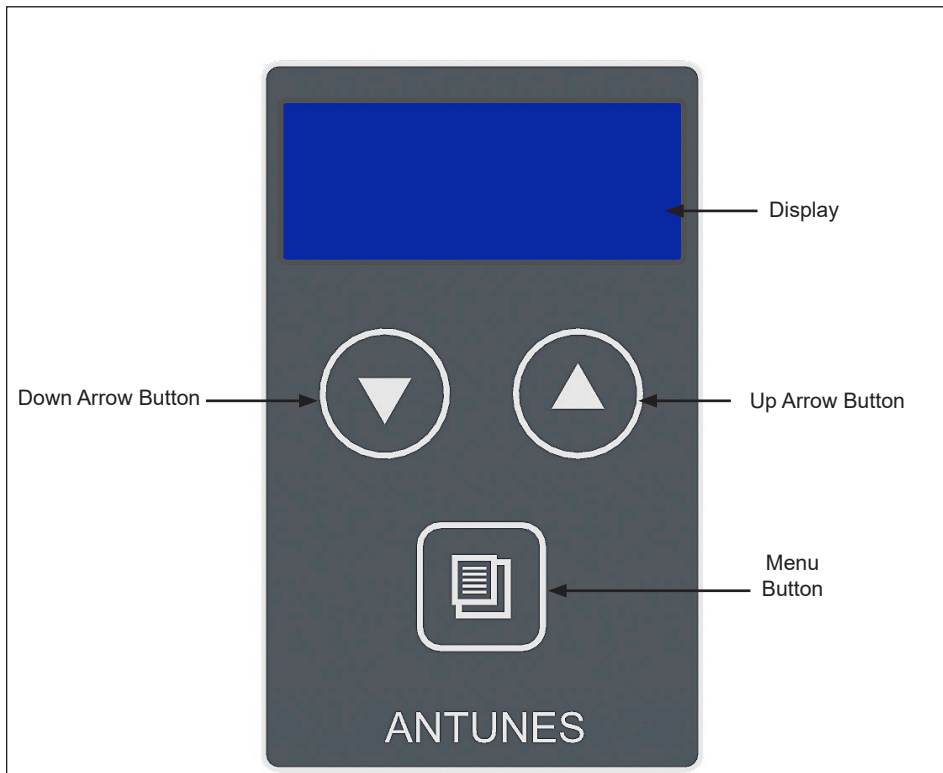

Figure 4. Control Panel and Display

Maintenance

Daily Cleaning

WARNING

Turn the power off, unplug the power cord, and allow the unit to cool to room temperature before performing any service or maintenance.

For daily cleaning steps refer to preventative maintenance card PR 74 provided with this manual

Replacing the Belt Wraps

(Replacement as Needed)

WARNING

Turn the power off, unplug the power cord, and allow the unit to cool to room temperature before performing any service or maintenance.

NOTE: Depending on toaster usage and how well they are cleaned daily will determine the lifespan of the Belt Wraps

1. Turn the power off, unplug the power cord, and allow the unit to cool before proceeding.
2. Put on heat-resistant gloves. Remove the Bun Feeder, Release Sheet, and Bun Chute and set aside (Figure 2).
3. Set the Bun Thickness Compression Knobs to 6. Open both Conveyor Covers.
4. If necessary, remove both existing Belt Wraps. Lift the flap on the Belt Wrap and disconnect the Belt Wrap hooks from the Conveyor Belt Chain. Discard used Belt Wraps.
5. Wipe the belts with a clean, sanitizer-soaked towel.
6. Install the new Belt Wraps onto the toaster under the support rods, making sure the flap is pointing down (Figure 5, 6, 7).
7. Connect the Belt Wrap hooks to the Conveyor Belt Chain, ensuring all hooks snap into place (Figure 6, 7, 8).

NOTE: Install the hooks on a smaller link/gap on the conveyor chain belt to ensure better performance.

NOTE: Make sure the Belt Wraps are installed under the support rods.

8. Close the Conveyor Covers.
9. Reinstall the Release Sheet, Bun Chute, and Bun Feeder and return the toaster to operation.



Figure 5. Replacing Belt Wraps



Figure 6. Connect Belt Wrap Hooks



Figure 7. Connect Belt Wrap Hooks

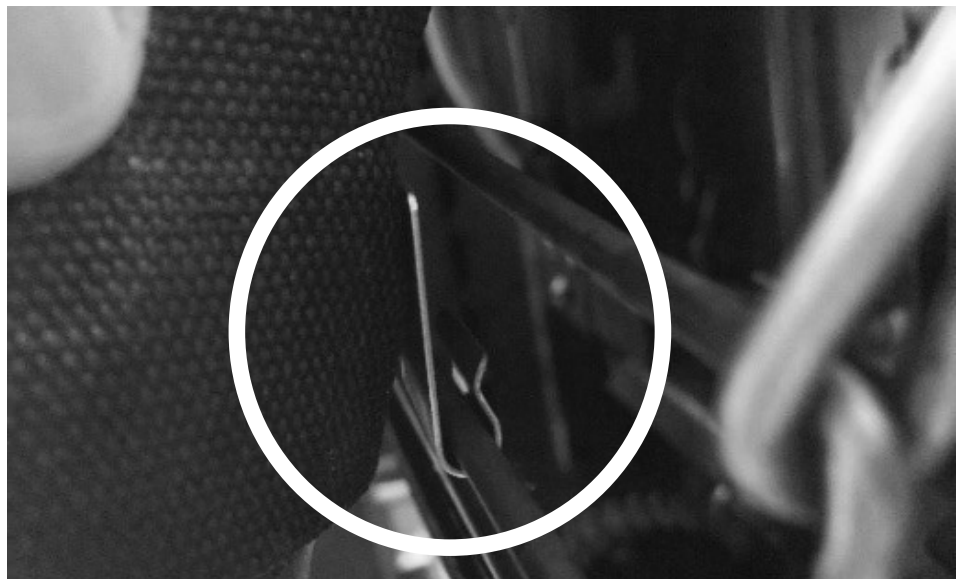

Figure 8. Check hooks snap into place

Checking the Conveyor Belt Chains

Measuring Conveyor Belt Chains

1. Turn the unit off, unplug the power cord, and allow the unit to cool.
2. Remove the Bun Feeder and Bun Chute (Figure 2). Set the Bun Thickness Compression Knobs to 6 & 6.
3. Open both Conveyor Covers.
4. Remove the Belt Wraps and set aside (Figure 5).
5. Facing the toaster, locate the approximate center-point of the Conveyor Belt Chain.
6. Pull the chain away from the edge of the toaster (Figure 9).
7. Measure the distance from the frame of the unit and the chain. A U.S. Dime (1.8 cm) can be used for the measurement (Figure 8).
8. If the gap is 2 times wider than the coin or larger than 3.6 cm, remove one 1/2" link as described below.
9. Disconnect the chain by squeezing any two links together and unhook the links from each other (Figure 10). Needle-nose pliers may be used.

NOTE: There are two small 1/2" links on each side of the Conveyor Belt Chain. The rest are large 3/4" links.

10. Remove one 1/2" link from the chain.
11. Reassemble the chain onto the sprockets as described in the Replacing Conveyor Belt Chains section of this manual.
12. Measure the gap again with the coin. The coin should fit snugly between the chain and frame.
13. Check the opposite side of the toaster using the same steps.
14. When finished, reassemble the unit and return to operation.

NOTE: If the ends of the Conveyor Belt Chain cannot be connected, remove an additional small 1/2" link and install a large 3/4" link in its place.

Replacing Conveyor Belt Chains

1. Turn the power off, unplug the power cord, and allow the unit to cool before proceeding.
2. Remove the Bun Chute and set the Compression Control Knobs to 6 & 6.
3. Open both Conveyor Covers.
4. Remove both Belt Wraps and set aside.
5. Disconnect the Conveyor Belt Chain by squeezing any two links together and unhook both ends of one link (Figure 9). Repeat on other side.
6. Place the new chain on the top sprockets with hook ends down.
7. Wrap the chain around the top and lower sprockets. Hook both ends together. Repeat on other side.

NOTE: The ends of the hooks must point down (Figure 10).

NOTE: Install the Conveyor Belt Chains under the upper and lower Support Rods.

8. If the Belt Wraps are in good condition, reinstall. Otherwise install new Belt Wraps.
9. Close the Conveyor Covers, set the Bun Thickness Compression Knobs back to their normal settings and reinstall the Bun Feeder and Bun Chute.



Figure 9. Measuring Conveyor Belt Chain

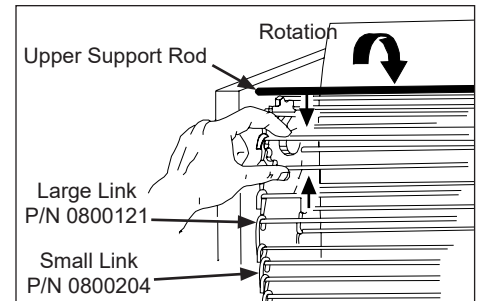

Figure 10. Removing Conveyor Belt Chain

Fault Codes

The table below describes error codes and the corrective action.

Error #	Cause/Description	Corrective Action
1	Cannot communicate with thermocouple A/D converter (U3). Potentially failed PC Board Component.	Turn unit off and back on again. If error persists, this may indicate a failed PC Board component. Contact Antunes Technical Service for assistance 877-392-7854.
2	Cannot detect power line zero cross. Potentially failed PC Board Component.	
3	Calibration check sum. Potentially failed PC Board Component.	
4	Microprocessor I2C buss communications error. Potentially failed PC Board Component.	
5	Microprocessor I2C buss communications error. Potentially failed PC Board Component.	
6	Cannot communicate with Fram (U9). Potentially failed PC Board Component.	
7	Cannot communicate with TMP75 (board temp sensor) (U4). Potentially failed PC Board Component.	
8	On-board voltage reference in thermocouple circuit failed (U1). Potentially failed PC Board Component.	
9	Not used.	Not Used
10	Board temp sensor exceeds 158° F.	Verify vents on toaster are unblocked and not near other heated appliances. If error persists, contact Antunes Technical Service for assistance 877-392-7854.
11	Main Hi Limit tripped.	Reset Hi Limit, turn unit off and back on again. If error persists, contact Antunes Technical Service for assistance 877-392-7854.
12	Cannot measure power line voltage Failed on-board transformer used for power control (T1).	Turn unit off and back on again. If error persists, contact Antunes Technical Service for assistance 877-392-7854.
13	USB port voltage below 4.5V - Something plugged into USB port.	Remove anything connected to the USB port, turn unit off and back on again. Turn unit off and back on again. If error persists, contact Antunes Technical Service for assistance 877-392-7854.
14	Main platen has not reached set point within 20 minutes.	Turn unit off and back on again. If error persists, contact Antunes Technical Service for assistance 877-392-7854.
15	Main platen has exceeded 650° F.	
16	Main platen has fallen 50°F below set point after Ready state.	
17	Main thermocouple failed (open).	
18	Aux has fallen 50°F below set point after Ready state; will clear from display if temperature recovers; error is logged into memory.	Make sure front and rear covers are in proper position. Turn unit off and back on again. If error persists, contact Antunes Technical Service for assistance 877-392-7854.
19	Auxiliary Heater exceeds 525° F.	
20	Auxiliary Heater does not reach set point within 20 minutes.	
21	Auxiliary thermocouple failed (open).	Turn unit off and back on again. If error persists, contact Antunes Technical Service for assistance 877-392-7854.
22	Auxiliary Hi Limit (hardware circuit trips at 550°F which turns off contactor; ER22 then shows within 2 seconds).	Turn unit off and back on again. If error persists, contact Antunes Technical Service for assistance 877-392-7854.
23	Cannot communicate with motor microprocessor (U13).	Turn unit off and back on again. If error persists, this may indicate a failed PC Board component. Contact Antunes Technical Service for assistance 877-392-7854.
24	Motor stopped.	Make sure no buns are stuck in conveyors or any obstructions around conveyors. Turn unit off and back on again. If error persists, contact Antunes Technical Service for assistance 877-392-7854.

Troubleshooting

Problem	Possible Cause	Corrective Action
No Control Display	Power cord not plugged in	Plug power cord into the proper electrical outlet.
	Circuit breakers turned off or tripped. Damaged electrical outlet, plug, or cord. Power switch damaged	Reset circuit breakers. If they trip again, check the power cord, plug, and outlet for damage. Contact Antunes Technical Service for assistance 877-392-7854.
	Power Switch not turned on or is faulty.	Turn the unit off and then on again. If the problem persists, contact Antunes Technical Service for assistance 877-392-7854.
	Faulty Transformer	
Conveyor does not rotate	Conveyor Belt/Chain has stretched. Chain skipping on sprockets.	Measure and adjust the conveyor belt chains as described in the Maintenance section of this manual.
	Loose setscrew on one of the drive sprockets	Contact Antunes Technical Service for assistance 877-392-7854.
	Motor Drive Chain loose	Contact Antunes Technical Service for assistance 877-392-7854.
	Internal part /object interfering within conveyor system	Check for interference & clear up as necessary.
Conveyor(s) skips or hesitates	Conveyor chains loose.	Measure and adjust the conveyor belt chains as described in the Maintenance section of this manual.
	Belt wrap clip not attached.	Verify both clips on each belt wrap are attached, reattach if necessary.
	Loose or misaligned sprocket	Contact Antunes Technical Service for assistance 877-392-7854.
	Motor drive chain loose or stretched	Contact Antunes Technical Service for assistance 877-392-7854.
	Drive motor(s) have failed	Contact Antunes Technical Service for assistance 877-392-7854.
Buns not toasting adequately	Compression settings are incorrect.	Use recommended setting or adjust compression knobs as needed to achieve desired toast quality.
	Release sheet is worn or needs cleaning.	Inspect release sheet for cleanliness, worn spots, wrinkles, or tears. Clean or replace release sheet as described in the Maintenance section of this manual.
	Platen has debris buildup.	Clean Platen as described in the Maintenance section of this manual.
	Light/Dark setting needs to be adjusted.	Adjust light/dark setting. See Operation section of this manual.
Crowns and/or Heels must be forced into the toaster. Buns sticking and burning.	Belt wraps are dirty, worn or damaged.	Clean or replace Belt Wraps as described in the Maintenance section of this manual.
	Platen has debris buildup.	Clean Platen as described in the Maintenance section of this manual.
	Release sheet is dirty, worn or damaged.	Clean both sides or replace release sheet as described in the Maintenance section of this manual.
	Conveyor Chains loose.	Adjust the conveyor belt chains as described in the Maintenance section of this manual.
	Drive motor stalls intermittently.	Contact Antunes Technical Service for assistance 877-392-7854.
	Compression settings are incorrect.	Use the recommended settings or adjust as needed to achieve desired toast quality.
	Buns are not inserted into the toaster properly.	Insert Crowns in front conveyor with and Heels in rear conveyor. Cut side of buns need to face the platen.
Toaster making unusual sounds	Fan needs to be cleaned or replaced.	Clean fan as described in the Maintenance section of this manual or contact Antunes Technical Service for assistance 877-392-7854.
	Conveyor belt chains have stretched or adjusted incorrectly.	Adjust the conveyor belt chains as described in the Maintenance section of this manual.
	Motor Drive chain needs lubrication.	Lubricate chain.
	Conveyor shaft bearing is binding.	Contact Antunes Technical Service for assistance 877-392-7854.
Buns getting caught in bun chute area	Bun chute installed incorrectly	Reinstall Bun chute correctly.

Replacement Parts

Parts list (see Exploded diagrams below)

Note			
Use only genuine Antunes replacement parts in this unit.			
Use of parts other than those supplied by the manufacturer will void the warranty.			

Item No.	Part #	Description	QTY.
1	0012982	Conveyor Belt Assembly 37/2	2
2	0013412	Inner Spring Tensioner Assy	4
3	0021951	Tensioner Bracket Weldment - Right	2
4	0021952	Tensioner Bracket Weldment - Left	1
5	0021959	Cam Weldment	2
6	0021961	Conveyor Cover Weldment	1
7	0022186	Bun Chute Weldment	1
8	0022194	End Hsg Weldment	1
9	0022195	Control Housing Weldment	1
10	0022295	Base Weldment	1
11	0022296	Bun Feeder Weldment	1
12	0022297	Weldment, Slide Shield - Crown	2
13	0022298	Weldment, Slide Shield - Heel	2
14	0022299	Weldment, Butter Wheel Roller (Mfg. No. 9210911 only)	1
15	0022300	Weldment , Conveyor Cover Rear	1
16	0100295	Platen, Grill 200V/1900W	1
17	0400138	Lock-Nut, Conduit-1/2" Npt	1
18	0400265	Bushing, Shorty 3/8"	4
19	0400315	Strain Relief-Cord Connector	1
20	0400432	Bushing, Open/Closed	1
22	0503495	Bracket, Retainer Right	2
23	0503497	Bracket, Tensioner-Left	1
24	0503507	Bracket, Retainer Left	2
25	0504321	Spacer 0.503 X 0.69 X 0.06"	1
26	0013412	Spring, Inner Tensioner	4
27	0506755	Retainer, Bearing	5
28	0507327	Butter Wheel Housing (Mfg. No. 9210911 only)	1

Item No.	Part #	Description	QTY.
29	0507500	Retainer, Bearing	1
30	0707507	Panel, Control (Mfg. No. 9210910 only)	1
31	0507508	Panel, End Housing (Mfg. No. 9210911 only)	1
32	0507509	Aux. Heater Retainer Clip	2
33	0507546	Pan, Butter (Mfg. No. 9210911 Only)	1
34	0507556	Panel, Electrical	1
35	0507557	Bracket, Contactor	1
36	0507558	Bracket, Thermocouple	1
37	0507559	Chain Tensioner Bracket	1
38	0507560	Motor Mounting Bracket	1
39	0600143	Spring, Compression Setting	1
40	0800455	Rod, Knob (Heel)	1
41	0800457	Rod, Knob (Crown)	1
42	0800458	Rod, Support	4
43	0800459	Rod, Bun Feeder	1
44	0800460	Shaft, Drive	2
45	0800900	Rod, Pivot, 3/16 O.d.	2
46	1000900	Label - Warning	1
47	1001181	Label, Crown	2
48	1001551	Label, Install	1
49	1001552	Label, Cam (Heel)	1
50	1002662	Label, Wiring Diagram	1
51	1002654	Label, Crown Compression	1
52	1002655	Label, Control	1
53	1031215	Spec Label	1
54	1070013	QR Label	1
55	2070135	Coupler (Mfg. No. 9210911 Only)	4
56	2100230	Bumper, Recess W/ Washer	4
57	2100378	Rail, Slide	4
58	2100393	Bottom Rail, Slide	2
59	2110127	Ring, Retaining	4
60	2120210	Spacer 0.503 X 0.690 X 0.532	1
61	2150179	Sprocket, 25B14 1/2" Bore	1
62	2150187	Chain, Drive	1
63	2150190	Sprocket, 25B28 1/2" Bore Stepped Tooth	8
64	2150212	Sprocket, 25B12 1/2" Bore (Mfg. No. 9210911 only)	1

Replacement Parts

Continued

Item No.	Part #	Description	QTY.
65	2150214	Sprocket, 25B30, 1/2" Bore (Mfg. No. 9210911 only)	1
66	2150250	Bearing, Flanged	1
67	2150251	Sprocket, 25B14 3/8" Bore	1
68	2150260	Bearing Sleeve	6
69	2150368	Miter Gear, 20° Pressure Angle	4
70	2150401	Chain, Drive (64 Links) (Mfg. No. 9210911 Only)	1
71	2150413	Sprocket, 25B20 1/2" Bore	2
72	2150414	Shaft, Idler	1
73	2150415	Coupler	1
74	2150418	Sprocket, 25B16 3/8" Bore	1
75	2150419	Assembly , Idler Shaft (Mfg. No. 9210911 Only)	1
76	2150420	Shaft, Drive (Mfg. No. 9210911 Only)	1
77	2180145	Cover, Bumper	4
78	300P124*	Ring, Retaining 3/8"	1
79	303P115*	Cotter Pin-1/16"	1
80	303P133*	Pin, Clevis	1
81	304P105*	Nut, Hex 'Keps' #4-40	1
82	306P102*	Washer, Int. Tooth #6	1
83	306P105*	Screw, Mach. #6-32 X 1/2"	1
84	308P102*	Washer, Int. Tooth #8	1
85	308P115*	Screw, Mach. #8-32 X 3/8"	1
86	308P124*	Screw, Mach One-Way #8-32	1
87	308P143*	Nut, Hex 'Keps' #8-32	1
88	308P145*	Nut, Hex Acorn #08-32 Low Crown	1
89	308P157*	Screw, Tap 8-32 X 3/8"Lg	1
90	308P181*	Scr, Mach #8-32 X 3/8" Phflthd	1
91	308P203*	Screw, Tap 8-32 X 3/8" W/Int. Tooth Washer	1
92	310P180*	Screw, Mach. #10-32 X 1-3/4"	1
93	310P199*	Scr, #10-32 X 3/8 Lg Socket Hd Cap	1

Item No.	Part #	Description	QTY.
94	310P213*	Screw, Phpnhd #10-16 X 3/4" Thrd Form	1
95	325P104*	Washer, Flat 1/4" S/S	1
96	325P203*	Washer, Spring Steel Single-Wave	1
97	4000186	Motor, 230V	1
98	4000202	Fan, Axial - 230V, Metal Housing & Imp	1
99	4010221	Cap-Mp, Motor Run	1
100	4010245	Switch, Rocker	1
101	4030352	Thermostat, Hi-Limit 700°F	1
102	4030455	Aux Heater, 200Vac, 550W	2
103	4050214	Thermocouple Type "K" (Open End)	1
104	4050229	Line Filter	1
105	4050236	Contact, 2 Pole No	1
106	4050240	Relay, Solid State Dual Pole W.Conn-Receipt	1
107	4060234	Wire Strap - 3/8"	1
108	4060466	C-Clip (Mfg. No. 9210911 Only)	4
109	4070154	Varistor Board	1
110	7002037	Black Wavy Silicone Belt	1
111	7001168	Platen Cover Sheet (3 pack)	1
112	4070238	Asy-PCB, VCT Mini Power Board	1
113	4070240	Asy-PCB, VCT Mini Control Board	1
114	3100228	SCR, SHLDR #10-32 x 1.125	1
115	0013313	End Housing Cover Assembly (Mfg. No. 9210911 only)	1
116	0507322	Cleaning Tool (Mfg. No. 9210911 only)	1
117	3020106	Rive, Semi Tubular - 3/16"	

* Items available in packages of 10 (ten)

Exploded Views

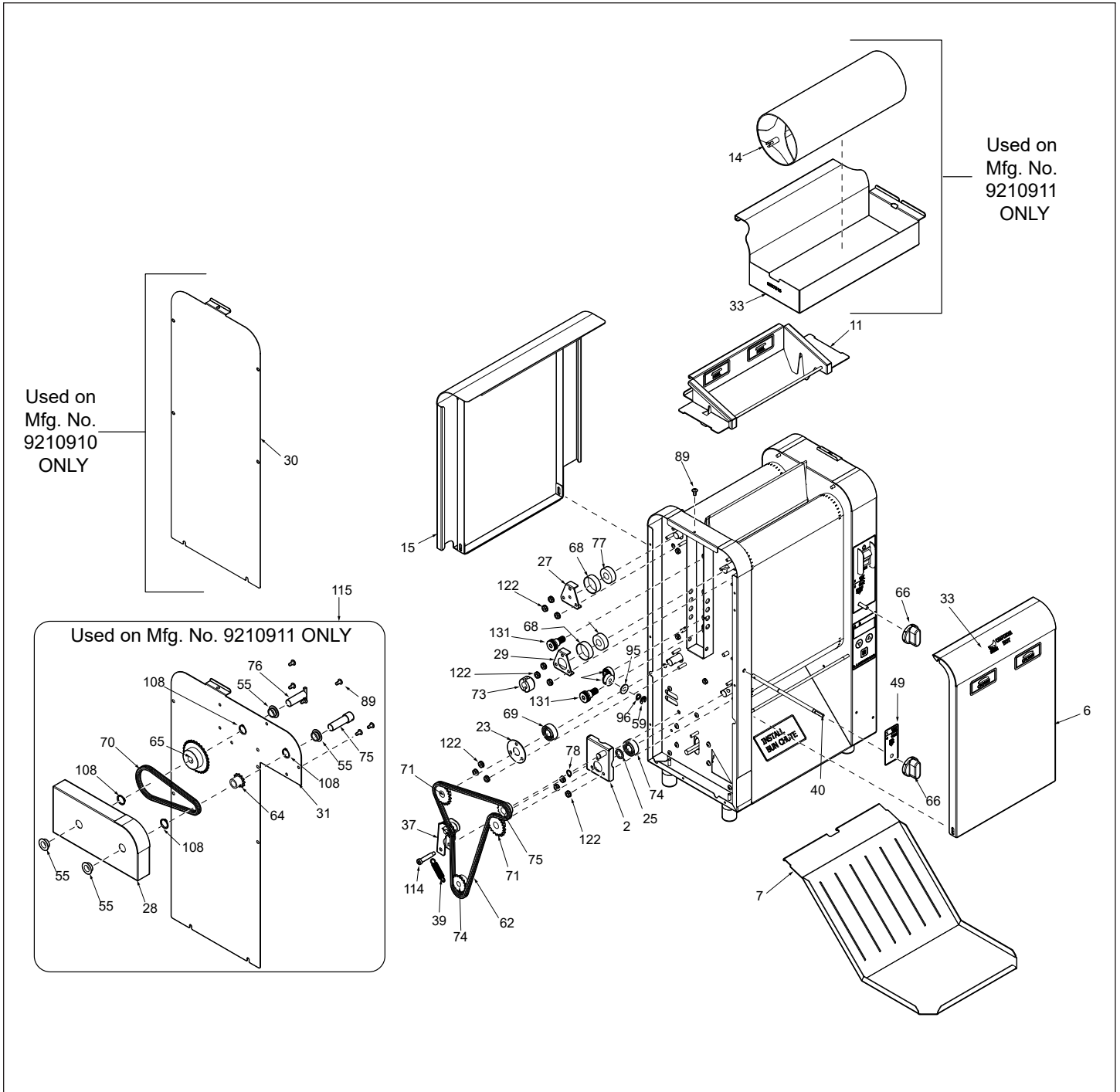

Exploded View 3

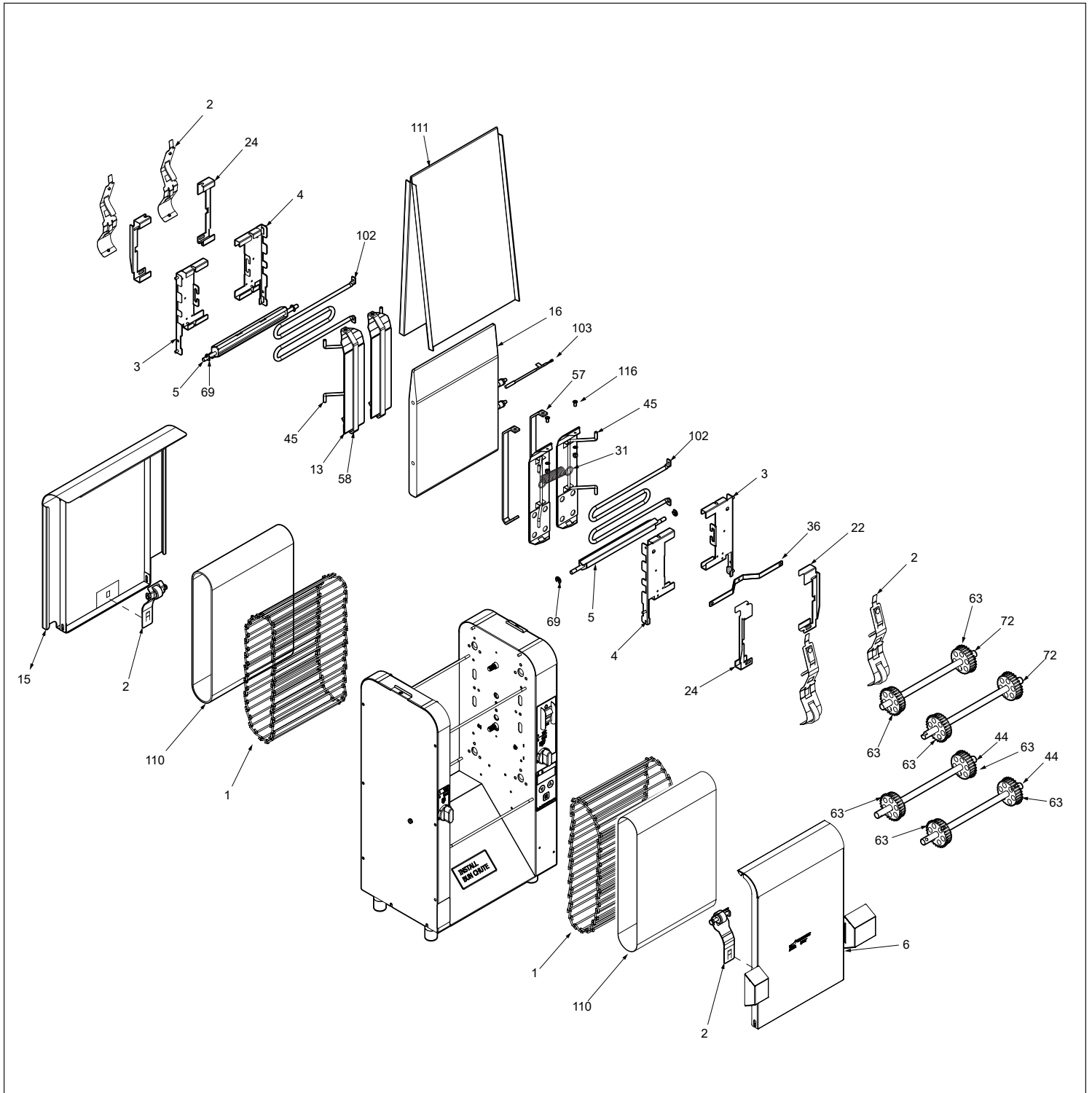

Exploded View 4

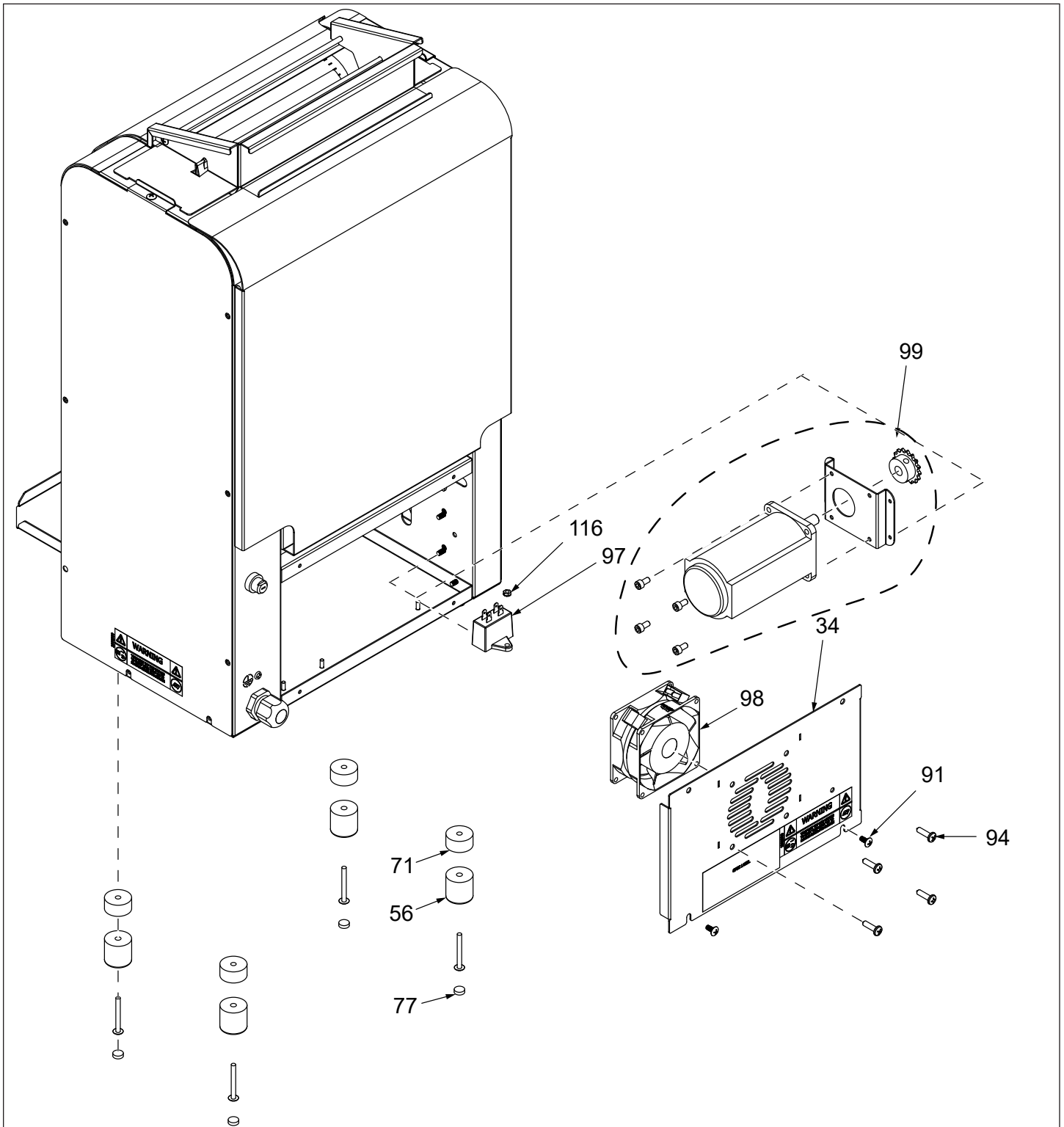

Wiring Diagram

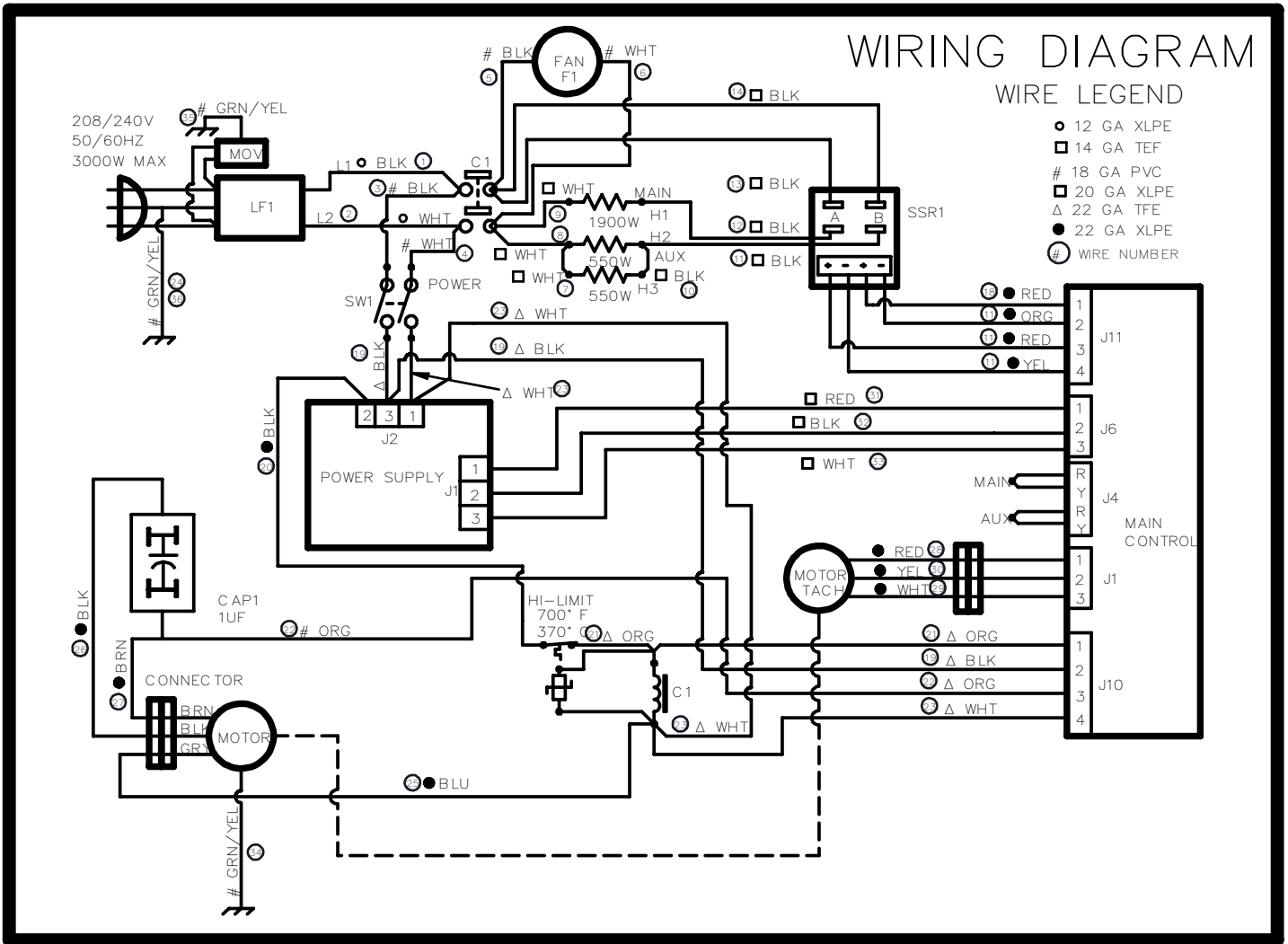

Limited Warranty

Equipment manufactured by Antunes has been constructed of the finest materials available and manufactured to high quality standards. These units are warranted to be free from electrical and mechanical defects for a period of one (1) year from date of purchase under normal use and service, and when installed in accordance with manufacturer's recommendations. To insure continued operation of the units, follow the maintenance procedures outlined in the Owner's Manual. During the first 12 months, electromechanical parts, non-overtime labor, and travel expenses up to 2 hours (100 miles/160 km), round trip from the nearest Authorized Service Center are covered.

1. This warranty does not cover cost of installation, defects caused by improper storage or handling prior to placing of the Equipment. This warranty does not cover overtime charges or work done by unauthorized service agencies or personnel. This warranty does not cover normal maintenance, calibration, or regular adjustments as specified in operating and maintenance instructions of this manual, and/or labor involved in moving adjacent objects to gain access to the equipment. This warranty does not cover consumable/wear items. This warranty does not cover damage to the Load Cell or Load Cell Assembly due to abuse, misuse, dropping of unit/shock loads or exceeding maximum weight capacity (4 lbs). This warranty does not cover water contamination problems such as foreign material in water lines or inside solenoid valves. It does not cover water pressure problems or failures resulting from improper/incorrect voltage supply. This warranty does not cover Travel Time & Mileage in excess of 2 hours (100 miles/160 km) round trip from the nearest authorized service agency.
2. Antunes reserves the right to make changes in design or add any improvements on any product. The right is always reserved to modify equipment because of factors beyond our control and government regulations. Changes to update equipment do not constitute a warranty charge.
3. If shipment is damaged in transit, the purchaser should make a claim directly upon the carrier. Careful inspection should be made of the shipment as soon as it arrives and visible damage should be noted upon the carrier's receipt. Damage should be reported to the carrier. This damage is not covered under this warranty.
4. Warranty charges do not include freight or foreign, excise, municipal or other sales or use taxes. All such freight and taxes are the responsibility of the purchaser.
5. THIS WARRANTY IS EXCLUSIVE AND IS IN LIEU OF ALL OTHER WARRANTIES, EXPRESSED OR IMPLIED, INCLUDING ANY IMPLIED WARRANTY OR MERCHANTABILITY OR FITNESS FOR A PARTICULAR PURPOSE, EACH OF WHICH IS HEREBY EXPRESSLY DISCLAIMED. THE REMEDIES DESCRIBED ABOVE ARE EXCLUSIVE AND IN NO EVENT SHALL ANTUNES BE LIABLE FOR SPECIAL CONSEQUENTIAL OR INCIDENTAL DAMAGES FOR THE BREACH OR DELAY IN PERFORMANCE OF THIS WARRANTY.

The warranty does not extend to:

- Damages caused in shipment
- Installation of electrical service
- Installation, calibration, or adjustment
- Normal maintenance outlined in this manual
- Consumable parts such as egg rings, gaskets, rubber feet, labels, O-rings, light bulbs, etc.
- Malfunction resulting from improper service or maintenance
- Damage caused by improper installation, improper use, abuse, or careless handling
- Damage from moisture coming in contact with electrical components
- Damage from tampering with, removal of, or changing preset controls or safety devices
- Damage caused by parts or components not provided by Antunes



Corporate Headquarters
Carol Stream, IL, USA
Phone: +1.630.784.1000
Toll Free: +1.800.253.2991
Fax: +1.(630).784-1650

China Facility
Suzhou, China
Phone: +84.512.6841.3637
Fax: +86.512.6841.3907

India Facility
Chennai, India
Phone: +91.44.25532212
Fax: +91.44.25532415