

Antunes  
WATER

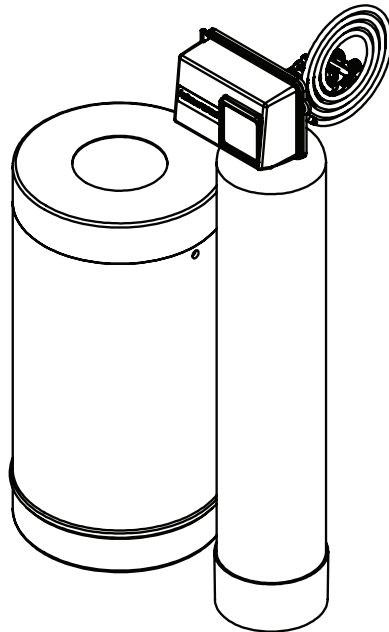

# Residential Water Softener System

Models

WSS-0948-R WSS-1252-R  
Owner's manual

Manufacturing Numbers:

9720010 & 9720011



# RESIDENTIAL WATER SOFTENER

## Contents

<b>General</b>	<b>2</b>
<b>Warranty Information</b>	<b>2</b>
<b>Service/Technical Assistance</b>	<b>2</b>
In Case of Damage	2
Equipment Information to Save	2
<b>Important Safety Information</b>	<b>3</b>
<b>Specifications</b>	<b>4</b>
<b>Water Softener Performance Data</b>	<b>5</b>
<b>Installation</b>	<b>7</b>
<b>Unpacking</b>	<b>7</b>
<b>Equipment Setup</b>	<b>7</b>
General	7
Electrical	7
Plumbing	7
Drain Connection	8
Setting the Clock	8
Placing the System into Service	8
Operation Check	8
<b>Maintenance</b>	<b>9</b>
Checking Salt Levels	9
Check Clock Time	9
Check Hardness Reduction	9
Cleaning the Salt Brine Tank	9
Replacing Softener Resin Tank	9
After a Power Failure	9
<b>Master Programming</b>	<b>10</b>
Master Programming Instructions	10
Enter Master Programming Mode	10
<b>Resets</b>	<b>10</b>
Soft Reset	10
Master Reset	10
Exit Master Programming Mode	10
<b>Troubleshooting</b>	<b>12</b>
<b>Replacement Parts List</b>	<b>13</b>
Exploded View	14
<b>NOTES</b>	<b>15</b>
<b>Limited Warranty</b>	<b>16</b>

## General

This manual provides important safety, installation, and operating procedures. All information contained in this manual should be read prior to installing and operating the system.

This system is manufactured from the finest materials available and is assembled to strict quality standards. This system has been tested at the factory to ensure dependable trouble-free operation.

## Warranty Information

Please read the full text of the Limited Warranty in this manual.

If the system arrives damaged, contact the carrier immediately and file a damage claim with them. Save all packing materials when filing a claim. Freight damage claims are the responsibility of the purchaser and are not covered under warranty.

The warranty does NOT extend to:

- Damages caused in shipment or damage as result of improper use.
- Installation of electrical service.
- Normal maintenance as outlined in this manual.
- Malfunction resulting from improper maintenance.
- Damage from moisture leaking into electrical components.
- Damage from tampering with, removal of, or changing any preset control or safety device.

## Service/Technical Assistance

### In Case of Damage

If any parts are missing or damaged, problems with the installation or operation of this product contact Antunes Customer Service immediately toll free at +1-877-392-7856.

If there are problems with the installation or operations of this product, contact Antunes Technical Service toll free at +1-877-392-7854.

Fill in the information in the next section and have it ready when calling for assistance. The serial number is on the specification sticker located on the system.

### Equipment Information to Save

Purchased from:

\_\_\_\_\_

Date of purchase:

\_\_\_\_\_

Model number:

\_\_\_\_\_

Serial number:

\_\_\_\_\_

Manufacturing number:

\_\_\_\_\_

### IMPORTANT

Keep these instructions for future reference.  
If the unit changes ownership, be sure this manual accompanies the equipment.

### CAUTION

When installed on metallic plumbing, a properly sized electrical bonding jumper must be installed across the inlet and outlet pipes serving this unit.

### IMPORTANT

Antunes reserves the right to change specifications and product design without notice. Such revisions do not entitle the buyer to corresponding changes, improvements, additions or replacements for previously purchased equipment.

### IMPORTANT

This equipment is to be installed to comply with the basic plumbing code of the Building Officials and Code Administrators, Inc. (BOCA) and the Food Service Sanitation Manual of the Food and Drug Administration (FDA).

### IMPORTANT

Water Flow Regulator Assemblies are NOT interchangeable. Operating the system with the wrong Water Flow Regulator or without a regulator can damage the system, cause personal injury, and voids the warranty!

## Important Safety Information

In addition to the warnings and cautions in this manual, use the following guidelines to safely operate the system:

- Read all instructions before using equipment.
- Install or locate the equipment only for its intended use as described in this manual.
- Do NOT use corrosive chemicals in this equipment.
- Do NOT operate this equipment if it has a damaged cord or plug; if it is not working properly, or if it has been damaged or dropped.
- This equipment should be serviced by qualified personnel only. Contact Antunes Technical Service for repair.
- Do NOT immerse cord or plug in water.
- Keep cord away from heated surfaces.
- This equipment should be supplied with only cold water.
- For installations in Massachusetts, the Commonwealth of Massachusetts Plumbing Code 248 CMR shall be adhered to. The use of saddle valves are not permitted. Please consult your local plumber.

The following warnings and cautions appear throughout this manual and should be carefully observed.

- This equipment is to be installed to comply with the local plumbing code and any other applicable code.
- Water pressure must not exceed 100 psig (690 kPa). To reduce water pressure, install a water pressure regulator and set to suit the application.
- When installed on metallic plumbing, a properly sized electrical bonding jumper must be installed across the inlet and outlet pipes serving this unit.

**NOTE:** If the inlet water pressure is less than 40 psig (276 kPa), it is recommended that a suitably-sized booster system be installed (outlet pressure 60 psig - 100 psig max/414-kPa - 690 kPa max).

### Protect from freezing

If the unit freezes during operation or storage, irreversible damage and brittle cracking of the housing may result.

### Protect from direct sunlight or other UV sources

Avoid long-term exposure to direct sunlight or other UV sources. The unit should be stored in a dark location.

### Protect from high temperatures or abrupt variation in temperature

The maximum operating temperature is 100°F (38°C). Avoid abrupt variations in temperature. Any temperature variation should be made slowly.

### Protect from rough handling or dropping

Mechanical damage, external breakage, and/or internal breakage of the filter can result if the system is dropped or bumped. Handle with care at all times during transportation and installation.

### Protect from organic solvents and concentrated acids

Prevent any and all contact of the system with strong solvents, solvents containing chlorine, or concentrated acids. Do NOT use strong solvents or concentrated acids on any plastic parts of the filter system. Examples of some solvents to avoid: acetone, methyl acetate (nail polish remover); hexane (spot removers); turpentine, toluene (paint thinners); dry cleaning solutions, insecticides.

### Protect from abrasive material

The system must be protected from abrasive materials like shavings left in a pipe. Abrasive materials in contact with the system can cause irreversible damage. All pipes must be flushed clean before installing the filter. All plastic parts of the filter system must be protected from sharp objects like knives, sand paper, or other tools. Cutting or nicking a plastic part can weaken it and cause a leak. Do NOT use abrasive cleansers on any plastic parts.

### Protect from water hammer

The system must be protected from shock, pressure surges, or pulsation that may occur inside water pipes. Water hammer occurs in pipes when a valve or faucet shuts quickly. Install a water hammer arrestor (pressure vessel containing compressed air separated from the water by a diaphragm) to reduce pressure shock.

# RESIDENTIAL WATER SOFTENER

## Specifications

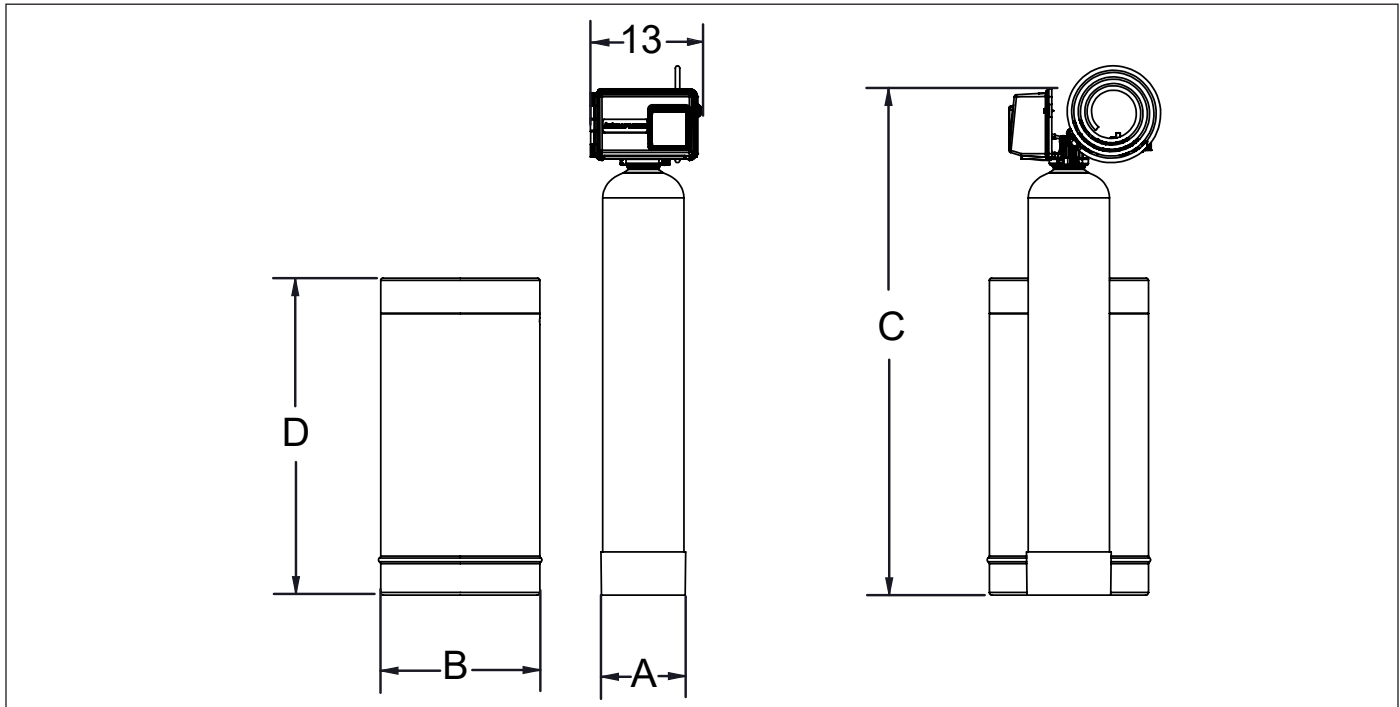

Model & Mfg. No.	Width (A)	Depth (B)	Height (C)	Height (D)	Operating Weight
WSS-0948-R 9720010 Resin Pressure Tank	9" (23 cm)		57" (145 cm)		125 lbs. (57 kg)
WSS-0948-R 9720010 Brine Tank		18" (45.7 cm)		36" (91.4 cm)	200 lbs. (91 kg)
WSS-1252-R 9720011 Resin Pressure Tank	12" (30.5 cm)		63" (160 cm)		220 lbs. (100 kg)
WSS-1252-R 9720011 Brine Tank		18" (45.7 cm)		36" (91.4 cm)	200 lbs. (91 kg)

Model	Drain must accommodate flow up to:
WSS-0948-R	2 gpm
WSS-1252-R	3.5 gpm

Electrical Ratings			
Volts	Hertz	Watts	Amps
120	50/60	40 VA	0.33

Electrical Cord and Plug
US NEMA 1-15 (2 pin) Or NEMA 5-16 (3 pin)

**CAUTION**  
When installed on metallic plumbing, a properly sized electrical bonding jumper must be installed across the inlet and outlet pipes serving this unit.

Model	Replacement Components	
	Kit, Softener Control Valve Replacement	Kit, Brine System Replacement
WSS-0948-R 9720010	7010016	7010015
WSS-1252-R 9720011	7010017	7010015

Model	Maximum Rated Service Flow	Water Consumption During Regeneration
WSS-0948-R 9720010	10 gpm	62 gallons
WSS-1252-R 9720011	11.5 gpm	94 gallons

# RESIDENTIAL WATER SOFTENER

## Water Softener Performance Data Sheet

Model	WSS-0948-R	WSS-1252-R	
Maximum Rated Service Flow (gpm) (W/upper collector)	10	11.5	
Pressure Drop at Rated Service Flow Rate (gpm)	15	15	
Rated Capacity (Grains @ lbs of salt)	18,000 @ 4.0 27,800 @ 9.0 31,500 @ 15.0	35,900 @ 8.0 55,700 @ 18.0 63,000 @ 30.0	
Rated Efficiency (grains/lb. Salt @ lbs. Of salt)	4490 @ 4.0	4490 @ 8.0	
Maximum Flow Rate During Regeneration (gpm)	2	3.5	
Resin Volume - ft <sup>3</sup> Resin Type - Purolite C100-E	1	2	
Tank Size	9" x 48"	12" x 52"	
Valve Cycle Time Settings (Minutes)	Backwash	8	8
	Brine Draw & Slow Rinse @ lb of Salt	56 @ 4.0 72 @ 9.0 90 @ 18.75	64 @ 8.0 80 @ 18.0 998 @ 30.0
	Rapid Rinse	8	8
	Fill @ lb of Salt	12 @ 4.0 24 @ 9.0 40 @ 15.0	12 @ 8.0 24 @ 18.0 40 @ 30.0

Operating Pressure: 20-125 psi or 1.4-8.8kg/Centimeter<sup>2</sup>, Operating Temperature: 34-110° F or 1.1-43.3°C Acceptable Salt Type: Sodium Chloride

All Systems above tested at 35psi+/-5 psi, pH of 7.5 +/-0.5, Capacity Testing Flow Rate = 50% of the rated service flow rate for the various size systems.

These water softener systems have been tested by the WQA and conform to NSF/ANSI 44 for specific performance claims as verified and substantiated by test data. The rated salt efficiencies above were also determined in accordance with NSF/ANSI 44 and are only valid at the salt dosage referenced above. An efficiency rated water softener is a demand initiated regeneration (DIR) softener which also complies with specific performance specifications intended to minimize the amount of regenerant brine and water used in its operation. Efficiency rated water softeners shall have a rated salt efficiency of not less than 3350 grains in total hardness exchanged per pound of salt (based on NaCl equivalency) (477 grams of total hardness exchanged per kilogram of salt), and shall not deliver more salt than its listed rating. The rated efficiency of the water softener, the salt dosage at that efficiency, the capacity at the salt dosage and that of the efficiency is only valid at the stated salt dosage. Efficiency is measured by a laboratory test described in NSF/ANSI 44. The test represents the maximum possible efficiency the system can achieve. Operational efficiency is the actual efficiency achieved after the system has been installed. It is typically less than the efficiency due to individual application factors including water hardness, water usage, and other contaminants that reduce the water softener's capacity. These systems are not intended to be used for treating water that is microbiologically unsafe or of unknown quality without adequate disinfection before or after the system. Refer to the system Installation and Service Manuals for set-up and programming instructions.

Contact your local dealer for parts and service. See your Owner's Manual for warranty information.



THIS PAGE LEFT INTENTIONALLY  
BLANK

# RESIDENTIAL WATER SOFTENER

## CAUTION

When placing the unit into service, pay attention to the following guidelines:

- Water Pressure: A minimum of 40 psi (2.8 bar) of water pressure is required for the system to operate effectively.
- Electrical Facilities: An uninterrupted alternating current (120 VAC) supply is required. The control uses a transformer to supply 12 VDC. Please make sure your voltage supply is compatible with your unit before installation.
- Existing Plumbing: Condition of existing plumbing should be free from lime and iron buildup. Piping that is built up heavily with lime and/or iron should be replaced. If piping is clogged with iron, a separate iron filter unit should be installed ahead of the water softener.

## Unpacking

1. Remove the softener from packaging and place on a sturdy work surface.
2. Remove any packing material from the inside of the system.
3. Remove component parts from inside the brine tank and cartons.
4. Inspect system for any broken components or fittings.

## Equipment Setup

### General

When placing the system into service, pay attention to the following guidelines:

- DO NOT immerse cord or power plug in water.
- Keep cord away from heated systems.

### Electrical

The line voltage must match the voltage on the specification label. The plug on the power cord must match the appropriate outlet. DO NOT connect the system to a switched electrical outlet.

### Plumbing

**NOTE:** The system must be connected to the COLD water line. DO NOT connect the system to the hot water line.

The softener system uses the following connections:

System Inlet	1" NPT Male
System Outlet (Softened Water)	1" NPT Male
Drain	1/2" ID Hose

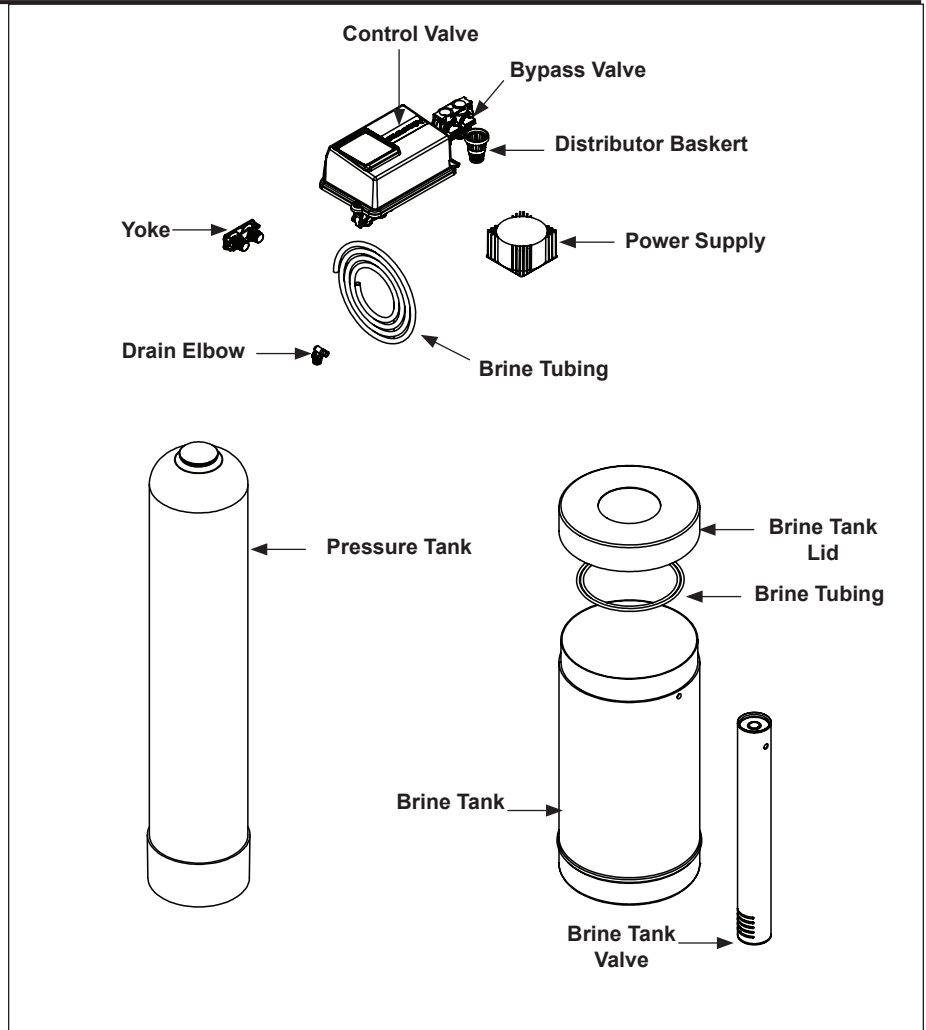

Figure 1. System Components (need better image of component names)

## Installation

### Suggested Tools and Supplies for Installation

The following tools and supplies are suggested to help with the installation:

- Level
- Tube Cutter
- Screw Driver
- Nut Driver
- Adjustable Wrenches
- Thread seal pipe tape
- Thread seal pipe dope
- Softener Salt
- Female adaptors, 1" NPT to connect to existing plumbing
- Pipe or tubing to connect to existing plumbing

**NOTE:** If any parts are damaged, contact Antunes Technical Service IMMEDIATELY at: +1-877-392-7854 (toll free).

1. Locate the softener resin tank and brine tank on a clean, level, firm surface. Remember that the tank, when filled with water, will weigh over 200 lbs.

**NOTE:** If the surface is not level, make sure to level it with a non-corrosive material. Wood shims are not recommended as they could deteriorate over time.

2. If you prefer to keep your outside taps unsoftened, you will need to install bypass lines for unsoftened hard water to the outside taps.
3. Install the top distributor basket to the control head.
4. Lubricate the tank o-ring and distributor o-ring using silicone lubricant.
5. Attach the control head to the resin tank by screwing it onto the top of the tank. Do NOT use any thread or pipe sealant on the tank threads. The control head seals when the o-ring is fully engaged.



# RESIDENTIAL WATER SOFTENER

## Drain Connection

The drain is for regenerating the softener resin and for flushing particle buildup out of the system during operation.

1. Apply pipe thread tape to threads of the drain fitting and attach the drain fitting to the control head at the drain port. Do NOT overtighten the fitting into the control head.
2. Attach the 1/2" ID drain hose to the barb of the drain fitting, and secure with a hose clamp.
3. Measure a sufficient length of hose from the drain outlet fitting to the drain.

When connecting the drain hose, pay attention to the following guidelines:

- The drain line plumbing must be able support the flow rate when the system regenerates.
- The drain line leading out of the system must be as short as possible and slope downwards without any kinks or loops.
- The drain line plumbing must be positioned and secured at least 2 inches above the drain (Figure 3). This air gap protects the system from contamination in the event of a backed-up drain.
- The drain used must not be blocked or restricted.
- The drain used must be as large or larger than the drain line plumbing.
- The drain line from the system should be secured at the drain using appropriate mounting hardware.

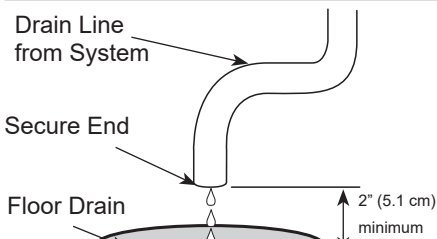
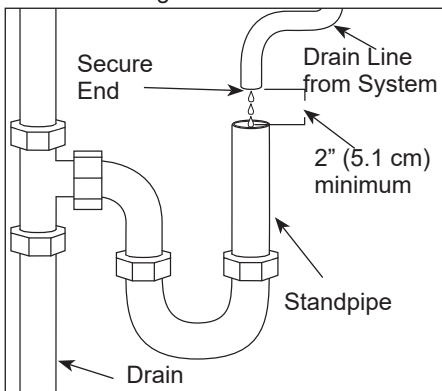

Figure 2. Drain Line Plumbing

4. Attach 3/8" OD brine tank tubing to the control head using the brass nut and sleeve provided. Do NOT overtighten the brass nut.
5. Attach the other end of the brine tank tubing to the brine tank float valve using the supplied nut and sleeves.

**OPTION:** If desired, connect the brine tank overflow hose from the overflow fitting to the floor drain.

6. Attach Hi-Flo bypass valve to the control head.
7. Attach the plastic yoke to the bypass valve.
8. Turn off main water supply.
9. Remove a section of existing pipe where the softener is going to be installed. The pipe removed should be large enough to allow the fittings needed to connect to the softener system.
10. Make sure to verify the inlet and outlet water flow directions on the softener and the existing plumbing before making connections.
11. Connect the incoming untreated water to the valve inlet. Connect the outlet water connection to the rest of the home plumbing.
12. Attach inlet and outlet fittings to the plastic yoke. The yoke has 1" NPT male threads. Use pipe tape and/or pipe dope on the threads. Use a backup wrench when making pipe connections. Do NOT overtighten fittings onto the plastic yoke.

**NOTE:** Make sure that local plumbing codes are followed when making connections.

13. Before proceeding, make sure the bypass valve is in bypass position. Bypass position is when the valve handles are across (perpendicular to) the valve bodies.
14. Turn on the main water supply and check all new fittings for leaks.
15. Secure the power transformer on the power cord to the wall or other location to remove the weight of the transformer from the cord.
16. Remove the lid of the brine tank and fill the brine tank with softener salt (at least 50 lbs.) Replace the lid when finished.



17. Plug the power cord from the control head into a grounded GFCI outlet. Make sure the control panel is illuminated.

## Setting the Clock

Program the controller to set the time of day.

1. Press and hold either the Up or Down arrow button on the controller until the programming icon replaces the service icon and the parameter display reads TD (Time of Day).
2. Adjust the displayed time with the Up and Down buttons.
3. When the correct time is set, press the Extra Cycle button to lock in the time and resume normal operation. The unit will also return to normal operation after 5 seconds if no buttons are pressed.



## Placing the System into Service

1. After the time of day is set, open the bypass valve. The open position is when the valve handles are in line with (parallel to) the valve bodies.
2. Check for leaks at all connections on the softener control head.
3. Activate a manual regeneration by pressing and holding the extra cycle button for 5 seconds. Air and water will come out of the softener drain line and water will fill the salt brine tank.

**NOTE:** The regeneration will take approximately an hour to complete.

4. After the regeneration is complete, the system is operational.

## Operation Check

1. Make sure the water supply to the softener is on.
2. Proper hardness reduction can be checked by measuring a sample of the outlet water for hardness.
3. Collect a water sample from any tap leading from the softener system. Run the water for several minutes to make sure soft water is at the tap.
4. Measure the hardness using any test that measures total hardness.



## Maintenance

### Every Week

#### Checking Salt Levels

**NOTE:** Abrasive 'hard' water contains high levels of calcium and magnesium, causing lime scale buildup and interfering with the steamer's ability to operate correctly.

1. Remove the lid of the brine tank.
2. Check the level of the salt in the brine tank. It is recommended that the brine tank should be filled at least half-full with salt. The salt should measure at least 3 inches above the water level.



3. Break up any salt bridges. Salt can form a solid layer or "bridge" in the brine tank. Break up any solid layers that have formed until the salt moves freely. This will ensure that the salt mixes properly with the water in the brine tank.

**NOTE:** For stubborn salt layers, warm water may be added to help break up solid pieces of salt.

4. Replace the brine tank lid when finished.
5. Once the salt brine tank has been filled, a manual regeneration can be activated if necessary. Press and hold the extra cycle button for 5 seconds to start a manual regeneration.
6. After the regeneration is complete, the system is operational.

**NOTE:** The regeneration will take approximately an hour to complete.

### Every Month

#### Check Clock Time

The clock should be checked monthly to make sure the local time is set properly.

1. Look at softener display and check that displayed time is the same as local time.
2. If time is incorrect, adjust the time by following the programming steps in the Installation section.

### Every Six Months

#### Check Hardness Reduction

The hardness reduction should be checked every 6 months. Use any test strips or tester that measures Total Hardness.

If Total Hardness coming from the softener system is not less than 1 grain per gallon (gpg), contact the factory for more information.

### Every Three Years

#### Cleaning the Salt Brine Tank

1. Unplug the power supply for the softener.
2. Remove the lid of the brine tank.
3. Disconnect all plumbing connections to the brine tank and empty the brine tank. Siphon or dump all water out of the tank, then dump out the salt and throw it away.

**NOTE:** Dissolve blocks or bridges of salt with hot water if needed.

4. Scrub with soapy water. Mix a generous amount of dish soap into one or two gallons (4-8 liters) of water. Pour it into the tank and scrub the entire interior with a brush.
5. Rinse the tank. Dump out the soapy water and rinse with plain water.
6. Replace the brine tank in the enclosure and reconnect all plumbing connections to the brine tank.
7. Fill the brine tank with salt.
8. Once the brine tank has been filled with salt, activate a manual regeneration by pressing and holding the extra cycle button for 5 seconds.

**NOTE:** The regeneration will take approximately an hour to complete.

### Every Five Years

#### Replacing the Softener Resin Tank

Consult the factory for replacement of the resin tank.

### After a Power Failure

#### Power Loss

The clock should be checked after a power loss to the softener system.

1. Look at softener display and check that displayed time is the same as local time.
2. If time is incorrect, adjust the time by following the programming steps in the Installation section.

# RESIDENTIAL WATER SOFTENER

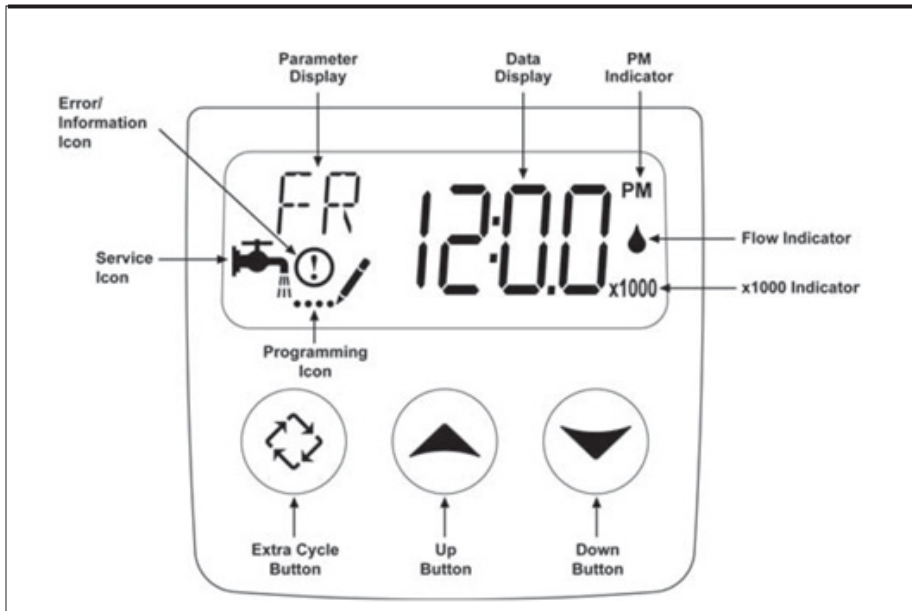

Figure 3. Softener Controller

## Master Programming

### Master Programming Instructions

When the Master Programming Mode is entered, all available option setting displays may be viewed and set as needed.

**WARNING:** These parameters are factory set and should not be changed without consulting the factory.

### Enter Master Programming Mode

1. Set the Time of Day display to 12:01 PM.
2. Press the Extra Cycle button (to exit Setting Time of Day mode).
3. Then press and hold the Up and Down Arrow Buttons together until the programming icon replaces the service icon and the Display Format screen appears.
4. Use the up and down arrows to change parameter values.
5. Press the Extra Cycle button to scroll to the next parameter.
6. Press the Extra Cycle button at the last parameter to save all settings and return to normal operation.

## Resets

### Soft Reset

1. Press and hold the Extra Cycle and Down buttons for 25 seconds while in normal Service mode.
2. This resets all parameters to the system default values [except the volume remaining in meter immediate or meter delayed mode and days since regeneration in the time clock mode].

### Master Reset

1. Hold the Extra Cycle button while powering up the system. This resets all the parameters in the unit.
2. Check and verify the choices selected in Master Programming mode.

**NOTE:** The control will automatically disregard any programming changes and return to normal operation if it is left in Master Programming mode for 5 minutes without any keypad input.

# RESIDENTIAL WATER SOFTENER

**NOTE:** THE FOLLOWING PARAMETERS ARE FACTORY DEFAULTS AND SHOULD ONLY BE CHANGED BY A QUALIFIED SERVICE PROFESSIONAL.

Abbreviation	Parameter	Factory Default		Description
		WSS-0948-R	WSS-1252-R	
DF	Display Format	GAL	GAL	Gallons
VT	Valve Type	DF1b	DF1b	Standard Down-Flow Single Backwash
CT	Control Type	Fd	Fd	Meter (Flow) Delayed
NT	Number of Tanks	1	1	Single Tank System
C	Unit Capacity, KGrains	27.8	55.7	Unit Capacity
H	Water Hardness, Grains	20	20	(Test water and adjust if incoming hardness is higher than 20 grains)
RS	Reserve Selection	SF	SF	Percentage Safety Factor
SF	Safety Factor %	15	15	Percentage of the system capacity to be used as a reserve
DO	Day Override	14	14	Not Used
RT	Re-Gen Time	2:00 AM	2:00 AM	Time of day for regeneration
BW	Backwash (BW)	8	8	Minutes
BD	Brine Draw (BD)	72	85	Minutes
RR	Rapid Rinse (RR)	8	8	Minutes
BF	Brine Refill (BR)	12	24	Minutes
FM	Flow Meter Type	t0.7	t0.7	3/4" Turbine Meter

Injector	#	0	1
Brine Line Flow Control Rate	GPM	0.125	0.25
Drain Line Flow Control Rate	GPM	2	3

# RESIDENTIAL WATER SOFTENER

## Troubleshooting

Problem	Possible Cause	Corrective Action
No water comes out of the filter system.	Inlet/Outlet valves closed.	Open the Inlet/Outlet valves.
	Regeneration timer is not set.	Set regeneration timer.
	Water pressure is too low.	Check incoming water pressure to ensure that it meets specifications. If not, boost the inlet water pressure.
	Controller valve is stuck.	Clean controller valve (consult factory).
Low water flow comes out of the filter system.	See Above.	See Above.
	The inlet water pressure is too low.	Boost the inlet water pressure.
Water isn't soft.	System regenerating, temporarily bypassed.	Wait for regeneration to complete.
	No salt in brine tank.	Add salt to brine tank.
	Salt is bridging in brine tank (not in contact with water).	Break up salt bridging.
	Salt level is below water level.	Add salt to brine tank so salt level is above water level.
	Water conditions changed.	Set the timer to regenerate more often or consider installing additional filtration.
Water splashes at drain during flush.	Drain line not positioned properly.	Reposition the end of the drain line.
	Drain not capable of handling flow rate.	Clean drain; find alternate drain.
Water leaks from system fitting or connection	Fitting broken or loose.	Tighten or replace the fitting.

**Replacement Parts List**

(See Exploded Views for more information)

**NOTE**

Use only genuine Antunes replacement parts in this unit. Use of parts other than those supplied by the manufacturer will void the warranty.

Item #	Part #	Description	Qty.
1	7010053	Control Valve, Plastic WSS-0948-R	1
	7010054	Control Valve, Plastic WSS-1252-R	1
2	7010046	High Flow Bypass Valve, Plastic	1
3	7010047	Yoke, 1" NPT, Plastic	1
4	7010042	Drain Line Flow Control WSS-0948-R	1
	7010043	Drain Line Flow Control WSS-1252-R	1
5	7010044	Drain Line Retainer	1
6	7010056	Drain Line Elbow Fitting	1
7	7010045	Brine Line Fitting	1
8	7010049	Brine Tank (with valve and lid)	1
9	7010048	Brine Tank Lid	1
10	7010050	Brine Valve	1
11	7010040	Brine Tubing, 3/8" OD	5ft
12	7010051	Pressure Resin Tank w/ Media, WSS-0948-R	1
	7010052	Pressure Resin Tank w/ Media, WSS-1252-R	1
13	7010041	Drain Line Tubing, 1/2" ID	20ft

# RESIDENTIAL WATER SOFTENER

## Replacement Parts

### Exploded View #1

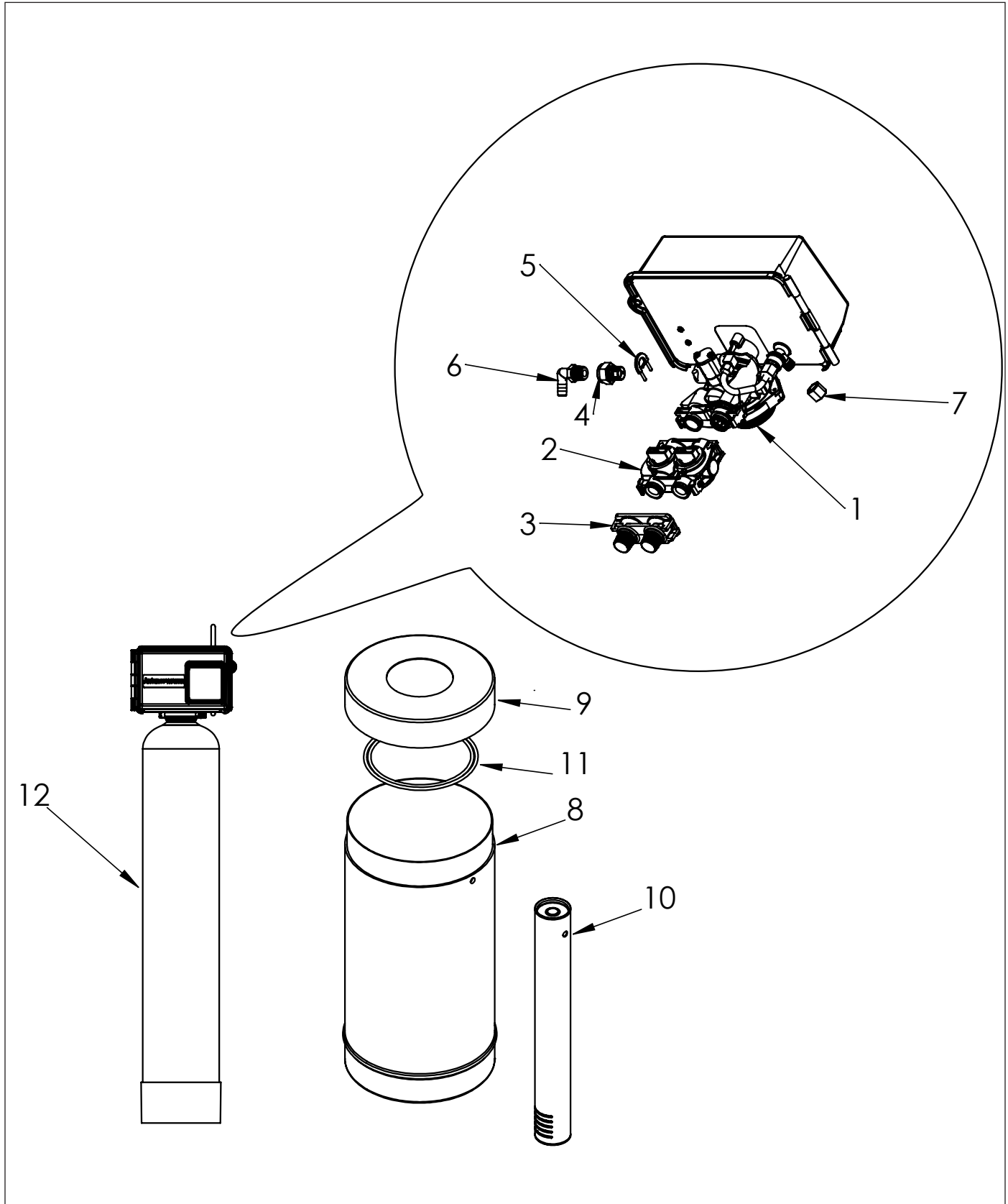





## Limited Warranty

Equipment manufactured by Antunes has been constructed of the finest materials available and manufactured to high quality standards. These units are warranted to be free from defects in materials and workmanship for a period of one year from date of purchase under normal use and service, and when installed in accordance with manufacturer's recommendations\*.

\*To ensure continued proper operation of the units, follow the maintenance procedure outlined in the Owner's Manual.

1. This warranty does not cover failures due to improper system installation, defects caused by improper storage or handling prior to placing of the equipment into service.
2. Antunes reserves the right to make changes in design or add any improvements on any product. The right is always reserved to modify equipment because of factors beyond our control and government regulations. Changes to update equipment DO NOT constitute a warranty charge.
3. THIS WARRANTY IS EXCLUSIVE AND IS IN LIEU OF ALL OTHER WARRANTIES, EXPRESSED OR IMPLIED, INCLUDING ANY IMPLIED WARRANTY OR MERCHANTABILITY OR FITNESS FOR A PARTICULAR PURPOSE, EACH OF WHICH IS HEREBY EXPRESSLY DISCLAIMED. THE REMEDIES DESCRIBED ABOVE ARE EXCLUSIVE AND IN NO EVENT SHALL ANTUNES BE LIABLE FOR SPECIAL CONSEQUENTIAL OR INCIDENTAL DAMAGES FOR THE BREACH OR DELAY IN PERFORMANCE OF THIS WARRANTY.
4. Prices and specifications are subject to change without notice.

### Corporate Headquarters

180 Kehoe Blvd.  
Carol Stream, IL 60188, USA  
Phone: +1.630.784.1000  
Toll Free: +1.800.253.2991  
Fax: +1.630.784.1650

### China Facility

2# Building North, 89 Songshan Rd.  
ShiShan Industrial Complex Park  
New District, Suzhou, China 215129  
Phone: +86.512.6841.3637  
Fax: +86.512.6841.3907

### India Facility

Antunes NADI Manufacturing India Pvt. Ltd.  
57-58 Thattankulam Rd., Madhavaram  
Chennai, India 600060

[www.antuneswater.com](http://www.antuneswater.com)