



## /// Easily protect expensive equipment and reduce maintenance costs by pairing the SI-XL Scale Inhibitor System with an ultrafiltration system.

Lime scale is one of the most significant maintenance problems for foodservice establishments. The SI-XL offers significant scale reduction to protect equipment and minimize downtime.

An ultrafiltration system reduces from the water almost all suspended particles as small as .015 microns, leaving virtually no sites for calcium to collect. The SI-XL features a unique composition blend that inhibits the lime scale caused by the hard water minerals left behind. It also controls staining caused by the precipitation of iron and manganese.

### FEATURES:

- /// Reduces scaling on ice machines.
- /// Ideal for use following an ultrafiltration system.
- /// Patented anti-scale dispensing system.
- /// Controls staining from iron and manganese.
- /// Maximum flow rate of 1.5 gpm (5 lpm).



SI-XL

## /// Scale Inhibitor System | SI-XL

### Specifications

Model & Mfg. No.	Max. Flow Rate	Inlet	Outlet
SI-XL 9700901	1.5 gpm (5 lpm)	3/4" FNPT	3/4" FNPT

### Dimensions

Model & Mfg. No.	Width (A)	Depth (B)	Height (C)	Operating Weight
SI-XL 9700901	5 3/8" (14 cm)	5 1/4" (13 cm)	14" (36 cm)	10 lbs. (4.54 kg)

### Shipping Dimensions

Model & Mfg. No.	Length	Width	Height	Weight
SI-XL 9700901	17" (43 cm)	12" (30 cm)	18" (46 cm)	8 lbs. (3.6 kg)

### Replacement Cartridges

Mfg. No.	Item Description
7000540	SI-XL Cartridge

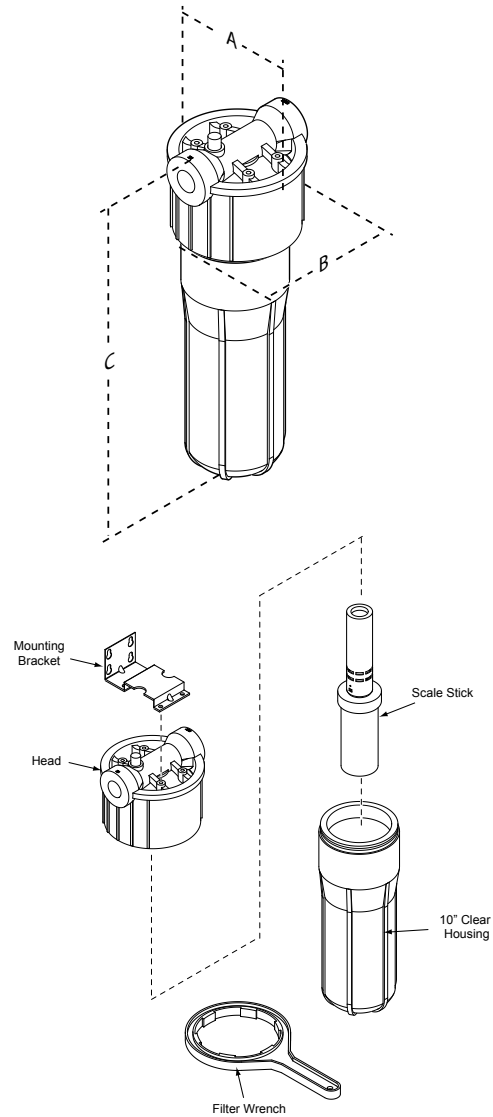

Scale Inhibitor System includes Scale Stick, 10" Scale Stick Clear Housing, Head, Mounting Bracket, and Filter Wrench.



Antunes delivers a complete range of countertop cooking equipment and water filtration solutions to foodservice operations around the world. Learn more about Antunes and its products at [antunes.com](http://antunes.com).

**Corporate Headquarters**  
Carol Stream, IL, USA  
Phone: +1.630.784.1000  
Toll Free: +1.800.253.2991

**China Facility**  
Suzhou, China  
Phone: +84.512.6841.3637  
Fax: +86.512.6841.3907

**India Facility**  
Chennai, India  
Phone: +91.442.5532212  
Fax: +91.442.5532415