

Mini Contact Toaster

Model VCT-2

Owner's Manual

Mfg. Numbers:

9210922 & 9210923

Contents

Overview	2
Before Use	2
In Case of Damage	2
Website	2
Service/Technical Assistance	2
In Case of Damage	2
Equipment Information to Save	2
Authorized Service Agency	2
Safety Information	3
Installation	3
Operation	3
Maintenance	3
Service	3
Specifications	4
Installation	5
Installing the Release Sheet	6
Bun Thickness Settings	6
Operating Instructions	7
Check Bun Compression Settings	7
Toasting Product	7
If product gets stuck inside toaster:	7
Adjusting Toast Quality	8
Shutting down the Toaster	8
Reset to Default Settings	8
Hi Limit Reset Button	8
Errors	8
Maintenance	9
Cleaning the Toaster	9
Cleaning the Release Sheet	9
Cleaning the Belt Wraps	9
Cleaning the Rear Fan	9
Weekly Maintenance	10
6 Month Maintenance	10
Monthly Cleaning	11
Cleaning the Conveyor Belt Chains	11
Checking the Chains for Stretching	12
Checking the Roller Tensioners	12
Reassembling the Toaster	12
Quarterly Cleaning	13
Replacing the Belt Wraps	14
Cleaning the Rear Fan	14
Troubleshooting	15
Troubleshooting (Continued)	16
Replacement Parts	18
Parts List	18
Replacement Parts (Continued)	19
Replacement Parts	20
Replacement Parts (continued)	21
Replacement Parts (Continued)	22
Replacement Parts (Continued)	23
Wiring Diagram	24
Notes	25
Limited Warranty	26

Overview

This unit is intended to be used for commercial applications, for example: in kitchens of restaurants, canteens, hospitals and in commercial enterprises such as bakeries, butcheries, etc., But not for continuous mass production of food.

Before Use

This manual contains safety, installation, and operating procedures for the unit. Read and understand it completely before installing or operating the unit. Keep this document for reference. If the unit changes ownership, this manual must accompany it.

In Case of Damage

If the unit arrives damaged, file a claim with the carrier immediately. Save all packing materials when filing a claim. Freight damage claims are the responsibility of the purchaser and are not covered under warranty.

Website

www.antunes.com

Service/Technical Assistance

In Case of Damage

If any parts are missing or damaged, contact Antunes Customer Service immediately at +1-877-392-7856 (toll free).

If there are problems with the installation or operation of this product, contact Antunes Technical Service toll free at +1-877-392-7854.

Fill in the information in the next column and have it handy when calling for assistance. The serial number is on the specification plate located on the system.

Equipment Information to Save

Purchased from:

Date of purchase:

Model number:

Serial number:

Manufacturing number:

Authorized Service Agency

Name:

Phone No:

Address:

Safety Information

Installation

- Read and understand all instructions before installing or using the unit.
- Install this unit to comply with the basic plumbing code of the Building Officials and Code Administrators, Inc. (BOCA) and the Food Service Sanitation Manual of the Food and Drug Administration (FDA).
- Install and locate the equipment only for its intended use as described in this manual.

WARNING

ELECTRICAL SHOCK HAZARD.
Failure to follow the instructions in this manual could result in serious injury or death.

Do not modify the power supply cord plug. If it does not fit the outlet, have a proper outlet installed by a qualified electrician.

The unit is furnished with a properly grounded cord connector. Do not attempt to defeat the grounded connector.

Electrical ground is required on this appliance.

The unit should be grounded according to local electrical codes to prevent the possibility of electrical shock. It requires a grounded receptacle with separate electrical lines, protected by fuses or circuit breaker of the proper rating.

Check with a qualified electrician if you are unsure if the appliance is properly grounded.

Do NOT use an extension cord with this product.

Operation

- Do not operate the unit if it has been damaged or dropped, if it has a damaged cord or plug, or if it is not working properly.
- Do not block or cover any openings on the equipment.
- Do not immerse the cord, unit, or plug in water.
- Keep the cord away from heated surfaces.
- Do not allow the cord to hang over the edge of a table or counter.
- This appliance is not to be used by persons (including children) with reduced physical, sensory or mental capabilities, or lack of experience and knowledge, unless they have been given supervision or instruction and understand the hazards involved.
- Children shall not play with the appliance.

Maintenance

- Do not use abrasive materials; they can damage the unit's stainless steel finish.
- Do not use corrosive chemicals in this equipment.
- Chlorides or phosphates in cleaning agents (e.g., bleach, sanitizers, degreasers, and detergents) can permanently damage stainless steel equipment. The damage is usually in the form of discoloration, dulling of the metal surface finish, pits, voids, holes, or cracks. This damage is permanent and is not covered by warranty.
- Always use a soft, damp cloth for cleaning. Rinse with clear water and wipe dry. When required, always rub in the direction of metal polish lines.
- Routine cleaning should be performed daily with soap and water.
- Rub off finger marks and smears using soap and water.
- Do not clean the unit with a water jet.
- Cleaning and user maintenance shall not be made by children without supervision.

Service

- Inspection, testing, and repair of electrical equipment must be performed only by qualified service personnel.
- Have the unit serviced only by qualified personnel. Contact Antunes Technical Service for adjustment or repair.
- Turn the power off, unplug the power cord, and allow unit to cool to room temperature before performing any service or maintenance.
- If the supply cord is damaged, it must be replaced by the manufacturer, its service agent, or a similarly qualified person in order to avoid an electrical hazard.

Specifications

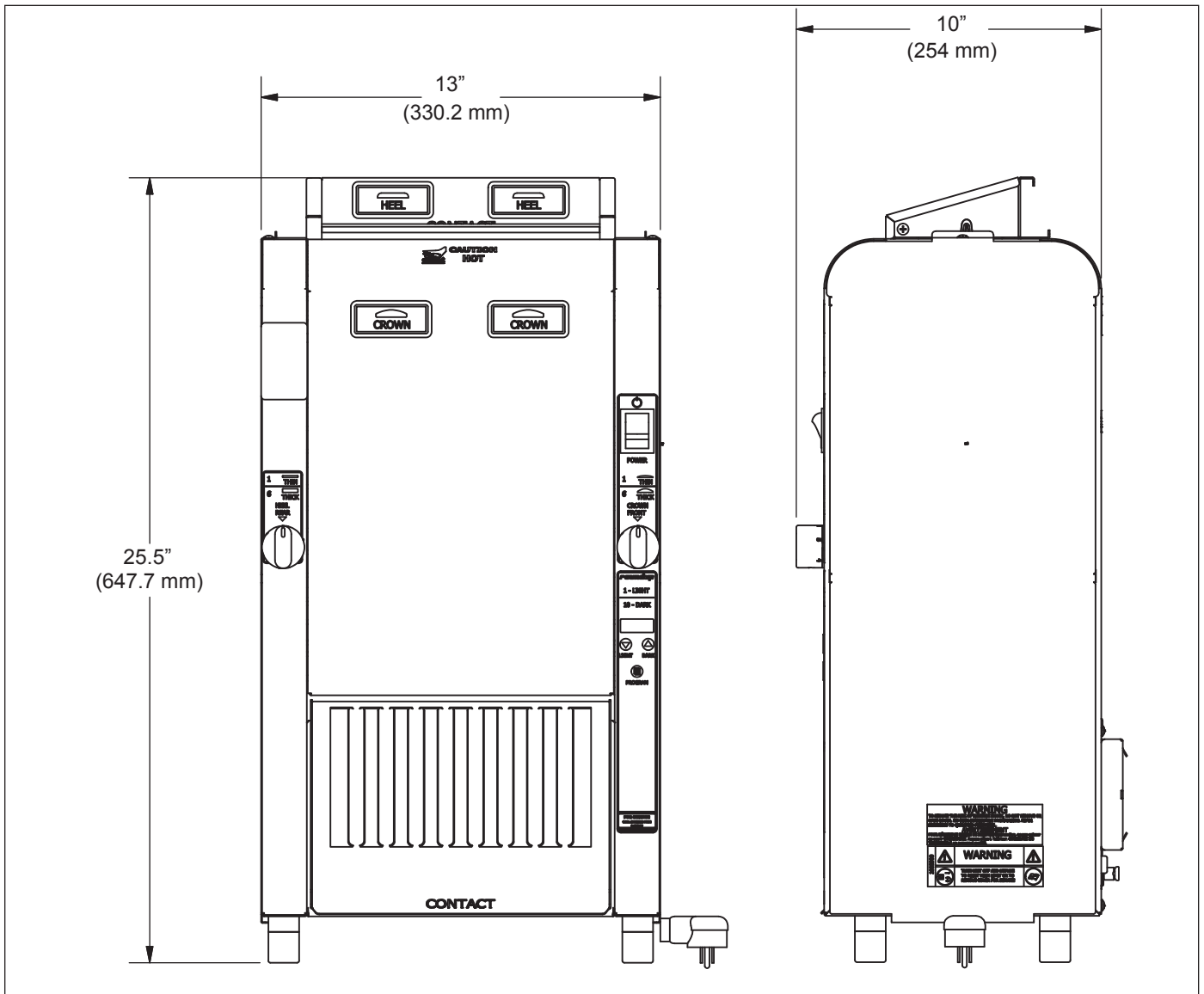

Model & Mfg. No.	Volts	Watts	Amps	Hertz	Plug Description
9210922 VCT-2	230	1900	15	50/60	Type G 13 Amp 230V
9210923 VCT-2	230	1900	15	50/60	Pin & Sleeve 16 Amp IEC-309

Installation

NOTE: When placing the toaster into service, make sure to provide at least 3 inches of space on all sides of the unit.

1. Remove unit and all packing materials from shipping carton. The toaster is shipped with an accessories box that includes the items listed below:

- Bun Feeder Assembly
- Bun Chute
- Release Sheet (pkg. Of 2) A Release sheet is also shipped installed onto the unit platen.
- Owner's Manual

NOTE: If any parts are missing or damaged, contact Antunes Customer Service IMMEDIATELY at +1-877-392-7856 (toll free).

2. Remove all packing materials and protective coverings from the unit.
 3. Refer to Figure 1. Wash, rinse, and sanitize the Bun Feeder, Bun Chute, and Cleaning tool at the 3 compartment sink and set aside to air dry.

NOTE: The removable parts have CONTACT etched on them to make it easier to identify which toaster they belong to.

4. Refer to Figure 1. Remove the Release Sheet.

NOTE: Do not wash the Release Sheet in the sink. The Release Sheet must be washed by hand.

5. Wipe all surfaces of the unit with a hot damp cloth.

6. Wipe both sides of the Release Sheet with a hot damp cloth.

NOTE: Do NOT use a dripping wet cloth. Wring out before use.

7. Install the Bun Feeder and Bun Chute onto the unit (Figure 1).

8. Refer to the section titled *Installing the Release Sheet* on the next page. Install the Release Sheet according to those instructions.

9. When placing the unit into service, pay attention to the following guidelines.

- Make sure to provide at least 3 inches of space on all sides of the unit.
- Make sure the power switch is off and the unit is at room temperature before plugging in the power cord.
- Do not block or cover any openings on the unit.
- Do not immerse the power cord or plug in water.
- Keep the power cord away from heated surfaces.
- Do not allow the power cord to hang over edge of table or counter.

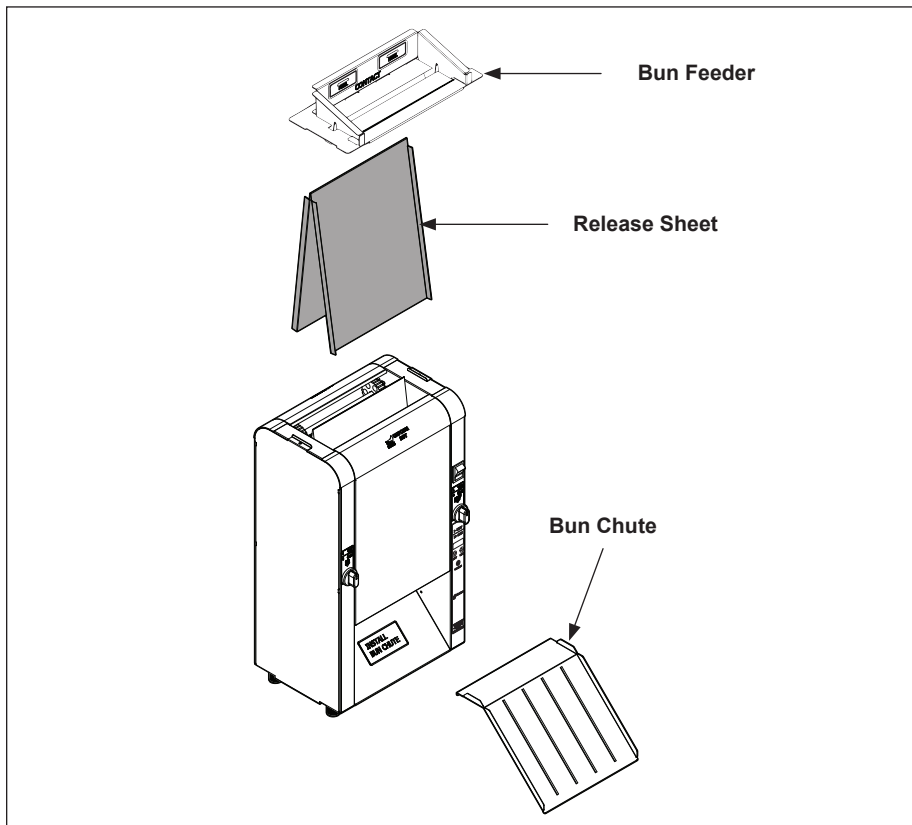

Figure 1. Components

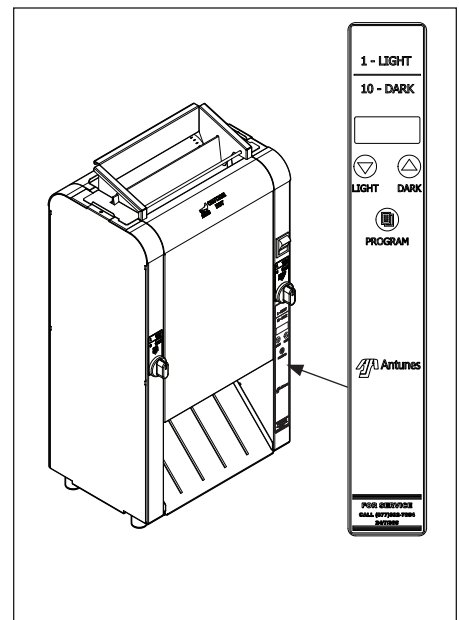
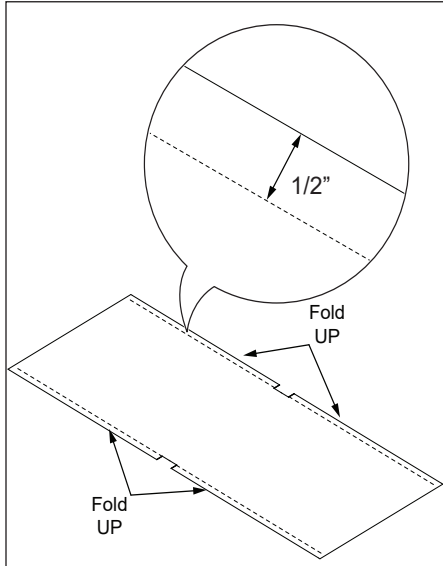

Figure 2. Control Panel

Installing the Release Sheet

The Release Sheet allows buns to pass through the toaster without sticking. The toaster should never be operated without a clean Release Sheet installed.

1. Fold and crease edges of Release Sheet as shown below.



2. Fold and crease Release Sheet in half at center point.

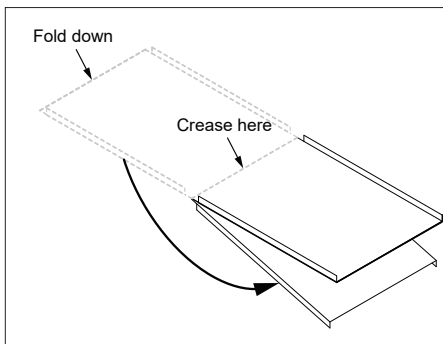

3. Turn unit on and Install Release Sheet over Platen. The unit will feed the Release Sheet into place. Re-install Bun Feeder.

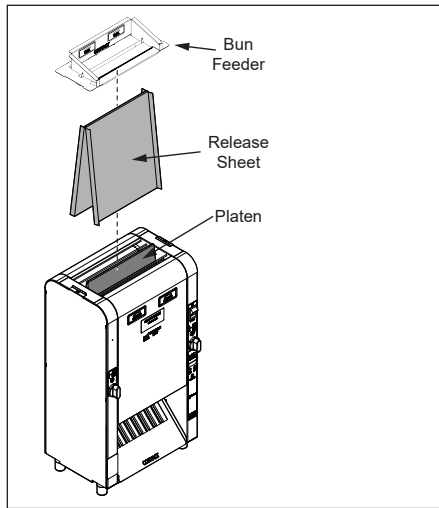

Bun Thickness Compression Knob Settings

The toaster uses two Bun Thickness Compression Knobs for proper toasting of buns (heels and crowns).

For best results, set both Bun Thickness Compression Knobs to 4.

The compression settings range from 1 to 6. Setting 1 is the thinnest setting and Setting 6 is the widest setting.

WARNING

Do NOT operate the toaster without the release sheet installed. Do not use any abrasive cleansers or tools such as scrubbers or scrapers on the Platen. Damage to the Platen from operation without a Release Sheet or damage caused from abrasive cleansers or tools voids the warranty.

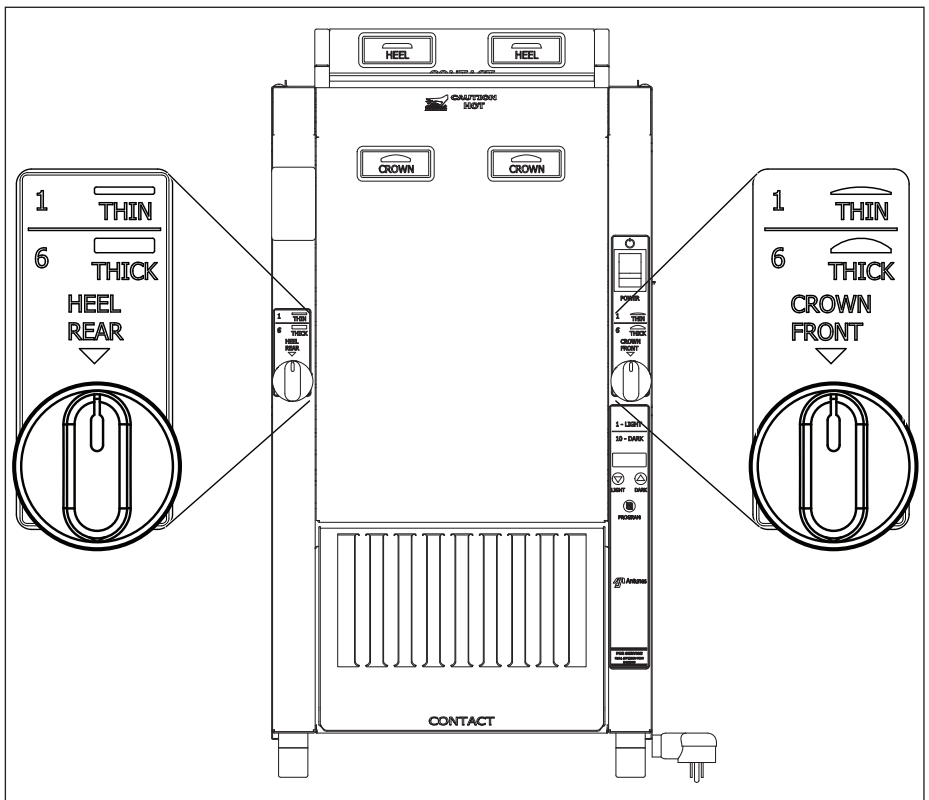
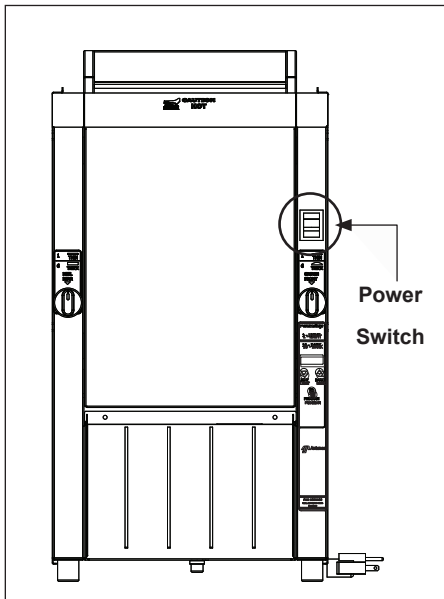

Figure 3. Bun Thickness Compression Settings

Operating Instructions

NOTE: If the toasting quality needs adjustment, refer to the section titled “Adjusting Toasting Quality” in the Operation section of this manual.

1. Verify that the toaster is clean and assembled correctly. Turn the Power switch to the on position. The unit makes a clicking sound. This is normal.
2. Place a red food tray in front of the Bun Chute.



3. After the system check, the unit begins to warm up and Lo-P appears on the display.

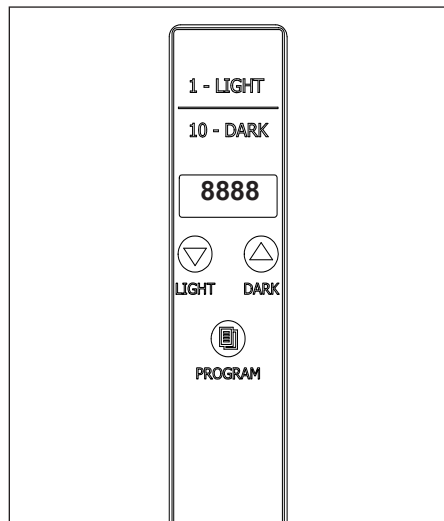

4. After the system check, the unit begins to warm up and Lo-P appears on the display.

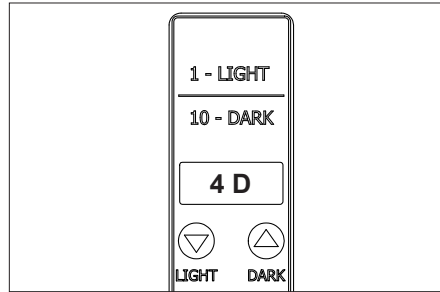

5. The unit displays the USE message when it reaches proper operating temperature (in approximately 10 minutes).

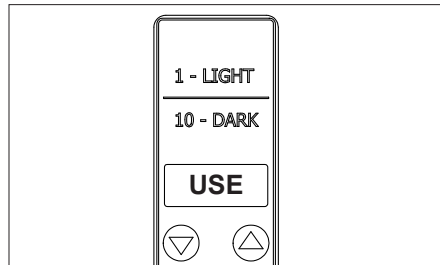

Check Bun Thickness Compression Settings

⚠ WARNING

Do NOT use the platen tool without a scrub pad installed. Be sure to insert the platen tool into the toaster with the scrub pad facing the toaster platen. Do not allow the metal portion of the platen tool to contact the toaster platen.

Before toasting product, verify that the Bun Thickness Compression Knobs are set appropriately. The typical settings for crowns and heels is #4, however these can be changed according to product thickness. See the section titled “Bun Thickness Compression Knob Settings” for more information.

Toasting Product

Test the toaster before use by toasting 1 bun and 1 slice of Wheatberry bread. Facing the front of the unit, insert product as described:

- Bun - Feed crown into front slot and heel into back slot, with cut sides facing each other.
- Wheatberry bread - place 1 slice of bread into back slot.

Check the color against Quality Photos (Buttered White Bun Toasting, Multi grain Bun Toasting, Chicken Salad Sandwich toasting). Adjust settings if needed.

NOTE: If bun or bread gets stuck in the toaster, use the platen tool to dislodge it from the toaster.

- Insert Crowns into the front lane with the cut side facing in.
- Insert Heels into the rear lane with the cut side facing in.

Refer to Figure 4 below.

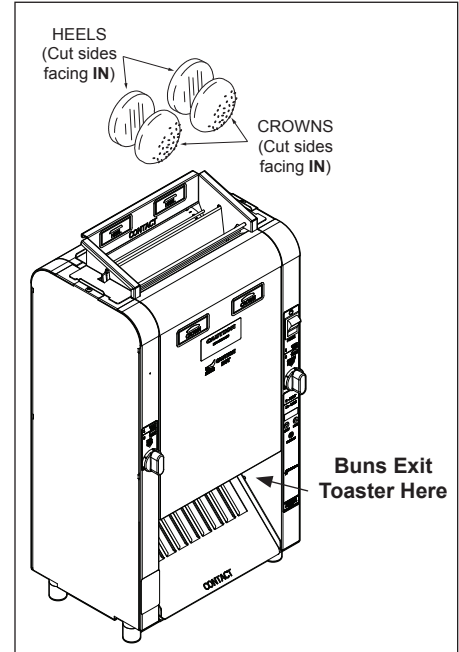

Figure 4. Toasting Product

If product gets stuck inside toaster:

If buns or a bread slice gets stuck inside the toaster, use the platen tool to dislodge it from the toaster. Before using the platen tool:

1. Insert one edge of a new scrub pad onto the top slot of the platen tool.
2. Insert the other edge of the scrub pad into the bottom slot. Make sure the scrub pad is flat against the tool.
3. From the top of the toaster, insert the platen tool with the pad facing the middle of the toaster. Dislodge product.

Adjusting Toast Quality

The unit can be adjusted to provide a lighter or more darkly toasted product.

The lightest setting is 1 and the darkest setting is 10.

Follow these steps to adjust toasting quality.

1. To view the current Light/Dark setting, briefly press **Light** or **Dark** button. The current Light/Dark setting appears in the display.

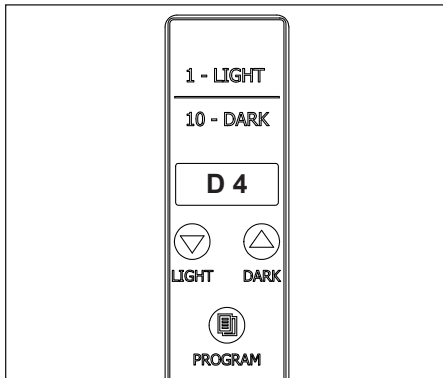

2. To change the Light/Dark setting, press and hold the **Light** or **Dark** button until the unit beeps.

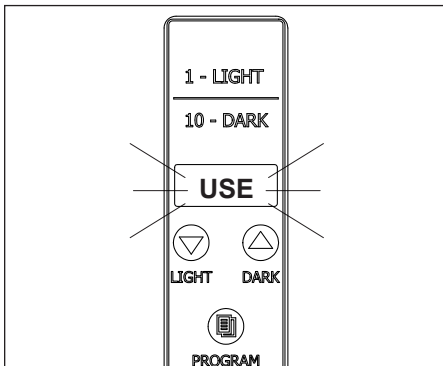

3. Press the Light or Dark button set the Light/Dark value as desired. Release the Button. The USE message flashes in the display as the unit adjusts the platen temperature accordingly.

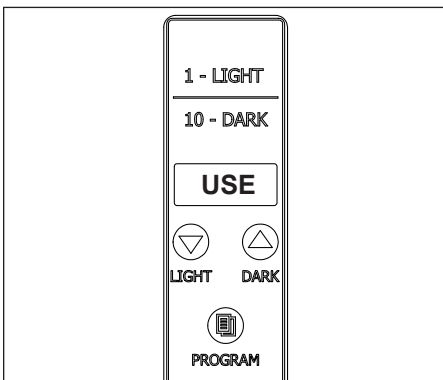

When the toaster reaches the newly set Light/Dark temperature, the USE message stops flashing and remains on. The toaster is ready for use.

NOTE: The Light/Dark value is maintained when the unit is powered off.

Shutting down the Toaster

To turn the toaster off, turn the Power switch to the off position.

Reset to Default Settings

Follow these steps to reset the toaster to the factory settings

Follow these steps to reset to default settings:

4. Turn the toaster off.
5. Press and hold both the Light and Dark buttons and turn the toaster on.
6. Continue holding the Light and Dark buttons until "f" (factory reset) appears in the display. The toaster beeps when resetting is done and starts up normally.

Hi Limit Reset Button

A hi-limit control turns off power to the unit if it overheats. To reset this Hi-Limit control, allow sufficient time (10-15 minutes) for the unit to cool down.

Remove the fan baffle by pulling the baffle pin and lift the baffle up and out (Figure 5). Then remove the Hi-Limit control cap by twisting the cap off by hand or with a coin (Figure 6). Then, press the reset button located on the rear of the unit.

If the unit requires continuous resetting, call for service.

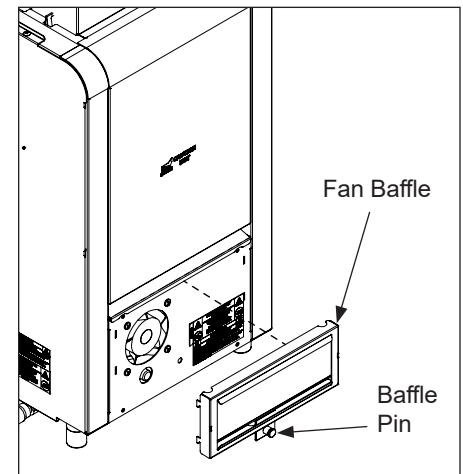

Figure 5. Remove Fan Baffle

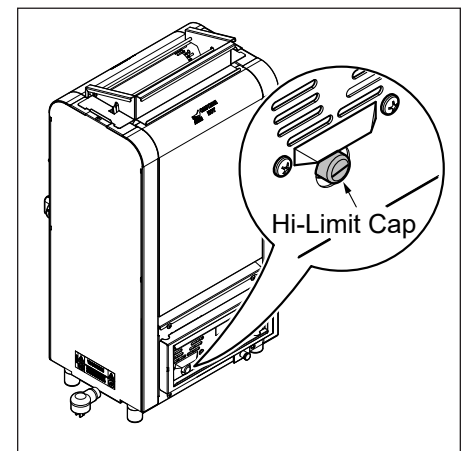

Figure 6. Hi-Limit Cap

Errors

The toaster displays any kind of error message, contact Technical Service: +1-630-784-3459

Maintenance

⚠ WARNING

The unit will remain hot while it is cooling down. Personal injury and burns may result from touching the unit before it is finished cooling down. Wear Heat Resistant Gloves.

Daily Maintenance

NOTE: The following are general maintenance procedures. For additional details including approved chemicals, please see the Toaster Procedure documents by scanning the QR Code on the front page of this manual.

The daily maintenance steps involve:

- Cleaning the Accessories and Toaster
- Cleaning the Release Sheet

Cleaning the Accessories and Toaster

1. Turn the toaster off and allow it to cool before proceeding.
2. Refer to Figure 7. Remove the Bun Feeder, Release Sheet, and Bun Chute and set aside.

NOTE: Do not wash the Release Sheet in the sink. It must be washed by hand.

3. Wash the Bun Feeder and Bun Chute in soap and water. Rinse with clean water and allow to air dry.
4. Wipe all surfaces of the unit with a hot damp cloth.

NOTE: Do not use a dripping wet cloth. Wring out before use.

Cleaning the Release Sheet

1. Inspect the Release Sheet. Replace the Release Sheet if it is worn, creased, or torn.
2. Spray an approved cleanser on a clean, dry towel.
3. Wipe the Release Sheet firmly from top to bottom.
4. Repeat this procedure with a clean, dry towel dampened with water.
5. Next, wipe the release sheet with a clean towel dampened with an approved sanitizer. Allow to air dry.
6. Repeat Steps 1 through 6 on the inside portion of the Release Sheet. Set the clean Release Sheet aside.

Cleaning the Belt Wraps

(9210922 ONLY)

1. Open the front and rear Conveyor Covers (Figure 8)
2. Inspect the front and rear Belt Wraps. Replace the Belt Wraps if there are any signs of tearing, folding, or other damage.
3. Turn on the unit.

NOTE: This step requires that the toaster be turned on with the Conveyor Covers open. Use caution during these steps.

4. Spray a clean, sanitized towel with an approved cleanser and wipe the front and rear Belt Wraps for one full rotation.
5. Repeat Step 4 with an approved sanitizer.

NOTE: Repeat these steps as needed until the Belt Wraps are clean and tacky/sticky to the touch.

6. Reinstall the Release Sheet, Bun Chute, and Bun Feeder and return the toaster to operation.

Cleaning the Rear Fan

Use a clean dry cloth and wipe the fan intake. The fan can be cleaned by using an Ecolab Detail Brush (item # 92212765) followed by a clean, dry cloth (see Figure 9). If there is heavy debris buildup, follow directions for Quarterly Cleaning the Rear Fan on page 14.

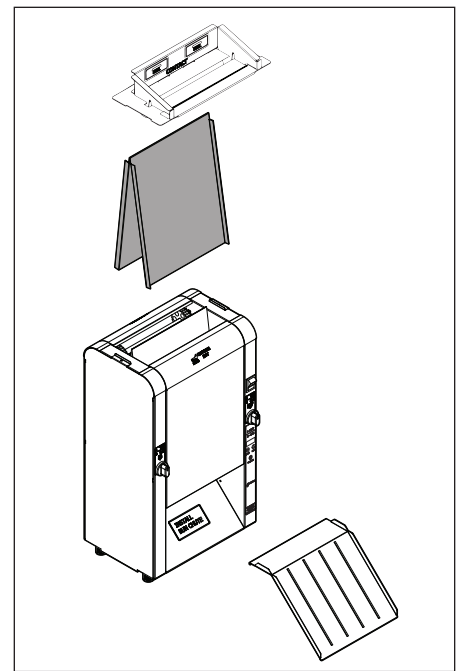

Figure 7. Remove Accessories

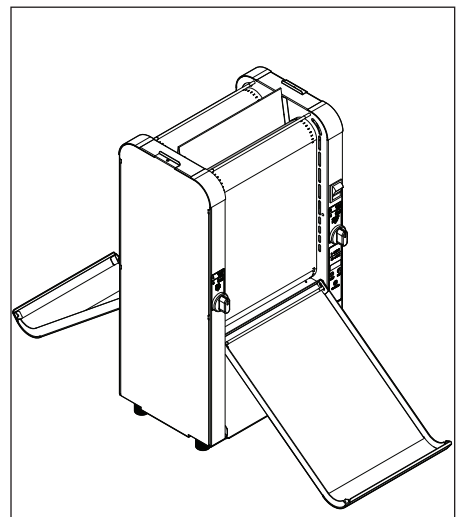

Figure 8. Open Covers

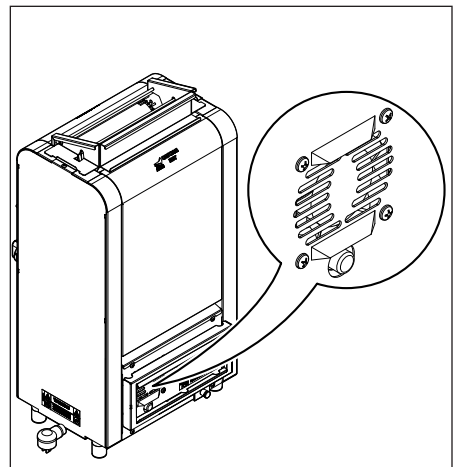

Figure 9. Rear Fan

Weekly Maintenance

Butter buildup on the platen will have a negative affect on toast quality. Follow the procedure below to clean the platen.

1. Turn the unit off, unplug the power cord and allow the unit to cool down for 15 minutes.
2. Put on heat resistant gloves. Remove the Bun Feeder, Release Sheet, and Bun Chute (Figure 11). Set these item aside.
3. Set both Bun thickness Compression Knobs to 6.
4. Place a food tray in front of toaster to collect drips from cleaning.
5. Insert a scrub pad into platen tool (Figure 10).
 - Inspect scrub pad to ensure it is clean and undamaged. Discard scrub pad if it has loose shreds, food particles or debris stuck in fibers.
 - Insert one edge of scrub pad into top slot.
 - Then, insert other edge into bottom slot, making sure pad is flat.
6. Prepare clean rinse water. It is helpful to have water in a 12 qt container next to toaster during cleaning process.
7. Spray Grill cleaner onto scrub pad.
8. Scrub each side of toasting platen gently with scrub pad, applying additional Grill cleaner to scrub pad as needed (Figure 5)

NOTE: Front and rear covers of toaster should be closed during this step to prevent Grill cleaner from dripping on the belt wraps or other areas of toaster.

9. Rinse scrub pad in clean water.
 - Press against scrub pad with gloved hand, while it is in water, to rinse it out.
 - Squeeze out excess water by scraping scrub pad against edge of container.

NOTE: It is important to squeeze out excess water because too much water dripping into toaster can damage electronic components.

10. Scrub each side of toasting platen gently with rinsed scrub pad to remove Grill cleaner residue. Continue rinsing scrub pad and scrubbing platen gently until all residue has been removed from platen.

NOTE: It will be necessary scrub each side of toasting platen with rinsed scrub pad approximately 4-5 times to remove all Grill cleaner residue.

11. Discard scrub pad. Scrub pads are for single use only.
12. Remove bun chute and red food tray and take them to compartment sink for cleaning.
13. Complete remaining steps in daily cleaning process. (See Contact Toaster: Cleaning Contact Toaster at End of Day.)

6 Month Maintenance

Inspecting the Drive Chain and Drive Chain Sprockets for proper lubrication.

1. Turn the unit off, unplug the power cord and allow the unit to cool down for 15 minutes.
2. Remove the left hand side panel by unscrewing the top screw.
3. Inspect the drive chain and sprockets for proper tension and alignment.
4. If the chain is dry and in need of lubrication, apply some light synthetic oil around the perimeter of the chain. (Lubrication P/N 2140152)
5. Reinstall the panel and screw in the top screw.
6. Plug the unit back into the outlet and check for proper operation.

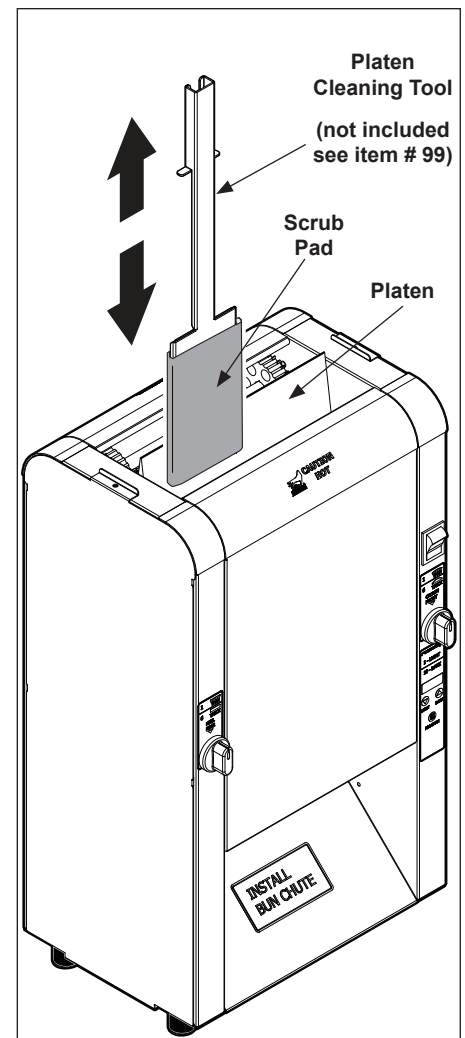

Figure 10. Scrub Platen tool

Monthly Cleaning

The monthly preventative maintenance steps include:

- Cleaning the Conveyor Belt Chains
- Checking the Conveyor Belt Chains for Stretching
- Checking the Roller Tensioners

Cleaning the Conveyor Belt Chains

1. Turn the unit off, unplug the power cord, and allow the unit to cool down.
2. Put on heat resistant gloves. Remove the Bun Feeder, Release Sheet, and Bun Chute (Figure 11). Set these items aside.
3. Set both Bun thickness Compression Knobs to 6. Next, open both Conveyor Covers (Figure 12).
4. Remove both Belt wraps (if necessary) - lift the flap on the Belt Wrap (Figure 13). Disconnect the Belt Wrap hooks from the Conveyor Chain and remove the Belt Wraps from the toaster (Figure 13).
5. Inspect the Belt Wraps (if necessary) for rips or tears. If the Belt Wraps are in good condition, set them aside. They will be reinstalled onto the toaster later in this process.
6. Use a Hi-Temp Detail Brush (Ecolab item# 92212765) to remove all debris and residue from the Conveyor Belt Chains. Do this on both sides of the toaster.
7. Clean and sanitize the front and rear Conveyor Belt Chain with a green scrub pad sprayed with Super Contact Cleaner solution. Wipe the links of the Conveyor Belt Chain firmly from side to side until they are completely free of residue and debris (Figure 14). Then, wipe the Chains with a clean sanitizer soaked towel.
8. Plug in the power cord and turn the unit on. Wait for both Conveyor Belt Chains to rotate and expose the uncleaned portion of the chains. Turn the unit off. Unplug the power cord. Repeat Steps 6 and 7 to clean and sanitize the soiled side of the Conveyor Chains.

NOTE: You may need to repeat steps 7 and 8 to ensure the Conveyor Belt Chains are completely free of debris and cleanser.

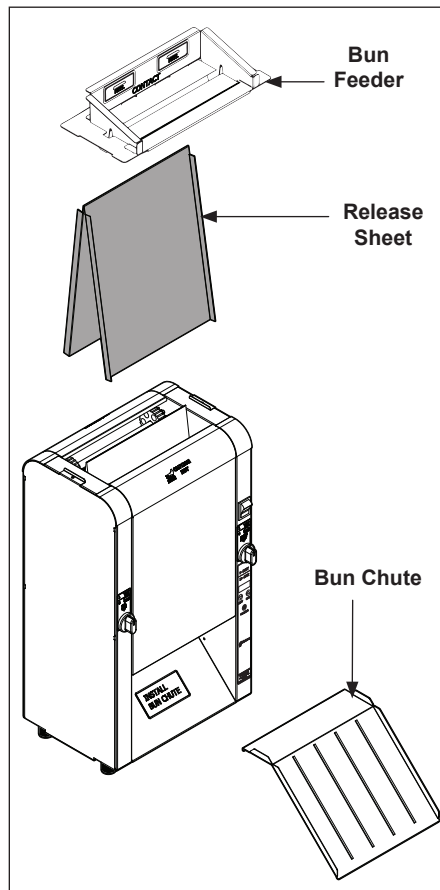

Figure 11. Remove Accessories

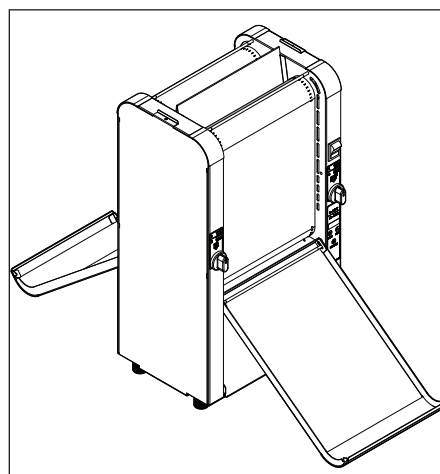

Figure 12. Open Covers



Figure 13. Remove Belt Wraps

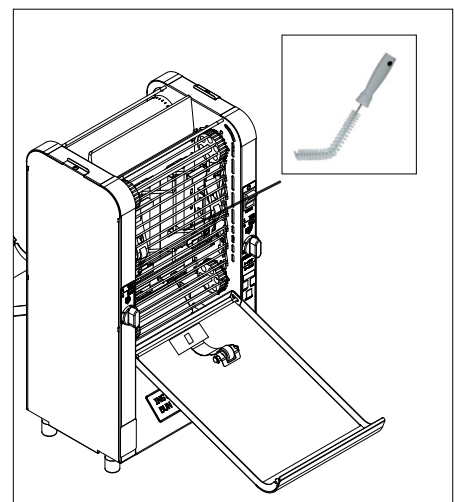

Figure 14. Clean Chains

Checking the Conveyor Belt Chains for Stretching

1. Set the Bun Thickness Compression Knobs to 6 and 6 and ensure both Belt Wraps are removed.
2. Locate the approximate center-point of the Conveyor Belt Chain.
3. Pull the Conveyor Belt Chain away from the edge of the toaster (Figure 15).
4. Using a U.S. Dime coin (1.8 cm) for reference or a ruler, measure the space between the toaster frame and the Conveyor Belt Chain (Figure 15). The coin should fit snugly.
5. If the gap is more than twice the width of the coin (2.6 cm):
 - Disconnect the Conveyor Belt chain by squeezing any two links together and unhooking both ends of the one link (Figure 16). Pliers may be used.

NOTE: There are two small 1/2 inch links on each side of the Conveyor Belt Chain. The rest are large 3/4 inch links.

- Depending on how loose the chain is, remove a 1/2" or 2/4" link.

NOTE: It is recommended to perform the Quarterly Cleaning any time you disconnect or remove a Conveyor Belt Chain from the toaster.

- Reassemble the Conveyor Belt Chain onto the sprockets.

NOTE: Make sure the Conveyor Belt Chain hooks are pointing DOWN as shown in Figure 15.

- Measure the gap again to confirm the gap is approximately the width of the U.S. Dime coin.
6. If the Conveyor Belt Chain is too tight, remove a small 1/2 inch link and install a large 3/4 inch link in its place. This increases the length of the Conveyor Belt Chain by 1/4 inch overall.
 7. Repeat steps 1 through 6 on the opposite Conveyor Belt Chain.



Figure 15. Measure with Dime coin

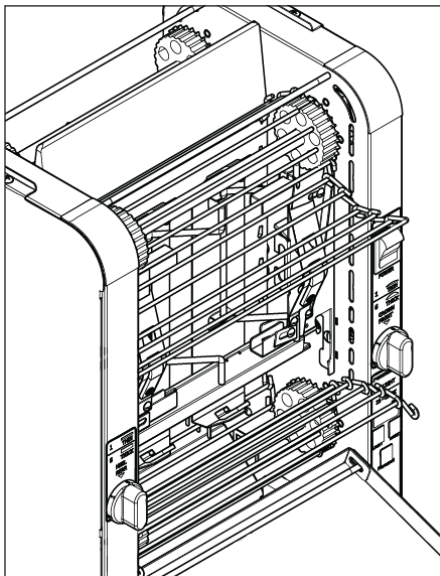

Figure 16. Disconnect Conveyor Belt chain

Checking the Roller Tensioners

1. Measure the Roller Tensioner on both inner Conveyor Covers using a U.S. Nickel (2.1 cm) for reference or a ruler (Figure 17).
2. Adjust the Roller Tensioners as needed by applying pressure to bend the tensioner down or up so the coin fits snugly between the roller and the Conveyor Cover wall.

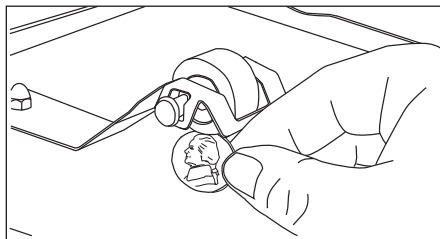

Figure 17. Check Roller Tensioners

Reassembling the Toaster

1. Reinstall the Belt Wraps onto the toaster under the support rods and making sure the flap is pointing down.
2. Connect the Belt Wrap hooks to the Conveyor Belt Chain, ensuring all hooks snap into place. (Figure 18)

NOTE: Make sure the Belt Wraps are installed under the support rods.

3. Close the Conveyor Covers.
4. Reinstall the Release Sheet, Bun Chute, and Bun Feeder and return the toaster to operation.

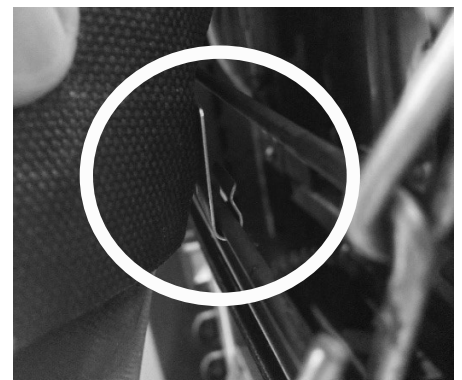

Figure 18. Reinstall Hook Belt Wraps

Quarterly Cleaning

The Quarterly Cleaning involves cleaning the interior of the unit. Follow these steps.

1. Turn the unit off, unplug the power cord and allow the unit to cool down.
2. Put on heat resistant gloves. Remove the Bun Feeder, Release Sheet, and Bun Chute (Figure 11). Set these items aside.
3. Set both Bun thickness Compression Knobs to 6. Next, open both Conveyor Covers.
4. Remove both Belt wraps if required. Disconnect the Belt Wrap hooks from the Conveyor Belt Chain and remove the Belt Wraps from the toaster (Figure 13).
5. Inspect the Belt Wraps for rips or tears. If the Belt Wraps are in good condition, set them aside. They will be reinstalled onto the toaster later in this process.
6. Disconnect the Conveyor Belt chains by squeezing any two links together and unhooking both ends of the one link (Figure 19). Pliers may be used. Remove the Conveyor Belt Chains and set aside.
7. Use Hi-Temp Detail Brush (Ecolab item# 92212765) to carefully remove all debris and residue from the inside components of the toaster (Figure 20). Do this on both sides of the toaster.

NOTE: With proper and regular daily and monthly cleaning, the interior of toaster should be free of residue and debris. If you find that the interior is extremely dirty on a regular basis, please review how the daily and monthly the frequency and daily and monthly cleaning steps.

8. Reassemble the Conveyor Belt Chain onto the sprockets.

NOTE: Make sure the Conveyor Belt Chain hooks are pointing DOWN as shown in Figure 15.

9. Reinstall the Belt Wraps (if required) onto the toaster under the yellow rods and making sure the flap is pointing down.

10. Connect the Belt Wrap hooks to the Conveyor Belt Chain.

NOTE: Make sure the Belt Wraps are installed under the support rods.

11. Close the Conveyor Covers.
12. Reinstall the Release Sheet, Bun Chute, and Bun Feeder and return the toaster to operation.

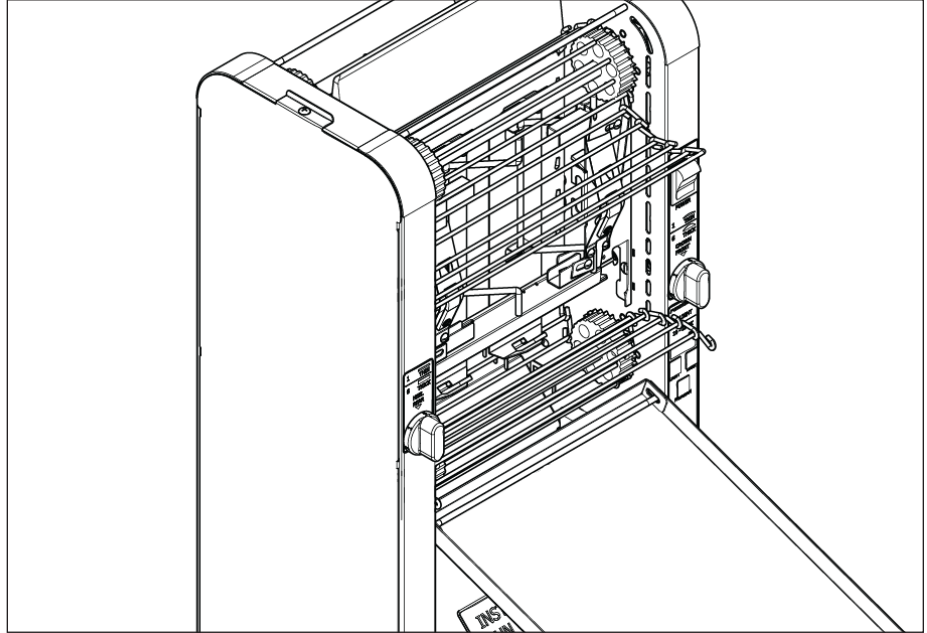

Figure 19. Disconnect Conveyor Belt chains

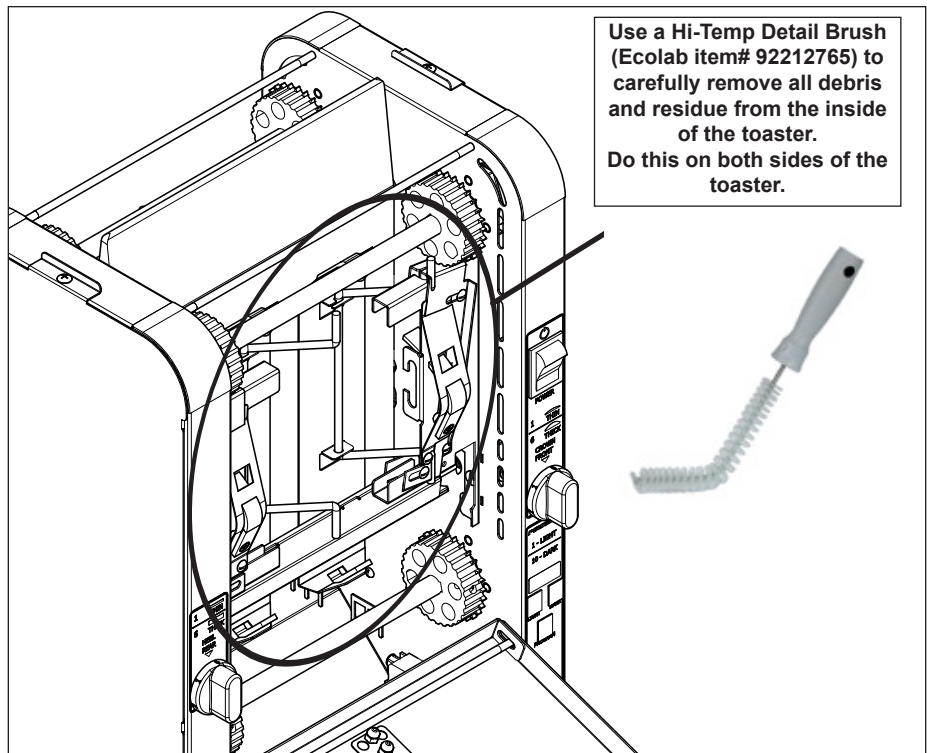

Figure 20. Remove all debris and residue with detail brush

Replacing the Belt Wraps

(9210922 ONLY)

The frequency of Belt Wrap replacement depends on usage and daily maintenance.

NOTE: Belt Wraps should feel sticky/tacky not slick/slippy.

1. Turn the unit off, unplug the power cord, and allow the unit to cool down.
2. Put on heat resistant gloves. Remove the Bun Feeder and Bun Chute (Figure 21). Set these items aside.
3. Next, open both Conveyor Covers (Figure 22).
4. Remove both Belt wraps - lift the flap on the Belt Wrap (Figure 18). Disconnect the Belt Wrap hooks from the Conveyor Chain and remove the Belt Wraps from the toaster (Figure 23).
5. Install the new Belt Wraps onto the toaster under the support rods and making sure the flap is pointing down.
6. Attach the Belt Wrap hooks to the Conveyor Chain.

NOTE: Verify both hooks are attached by pulling belt wrap away from chain and reattach if needed.

7. Close the Conveyor Covers.
8. Reinstall the Bun Chute and Bun Feeder and return the toaster to operation.

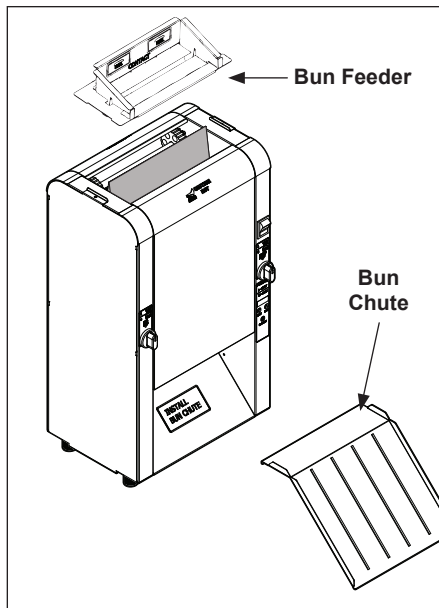

Figure 21. Remove accessories

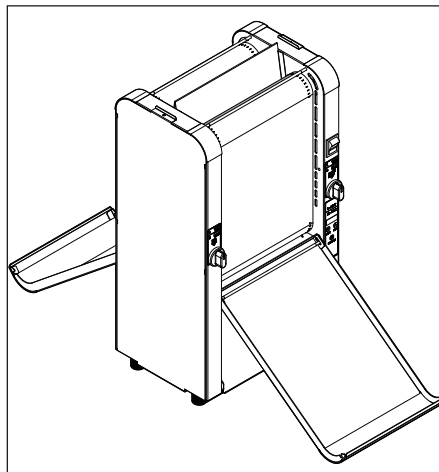

Figure 22. Open conveyor covers



Figure 23. Remove belt wraps

Cleaning the Rear Fan

1. Turn the unit off, unplug the power cord, and allow the unit to cool for 15 minutes before proceeding.
2. Refer to Figure 24. Pull the pin on the lower part of the baffle and rotate upwards to remove.
3. Refer to Figure 25. Remove the four Rear Panel screws circled and set aside.
4. Carefully remove the Rear Panel and lay it down so the fan is accessible.
5. Wipe inner surface of the Rear Panel and rear compartment with a clean, dry cloth to remove all debris and residue.
6. Use a clean, dry towel or Hi-Temp Detail Brush (Ecolab item# 92212765) to remove all debris and residue from the Fan.
7. Reattach the Rear Panel and secure with the screws removed in Step 2.

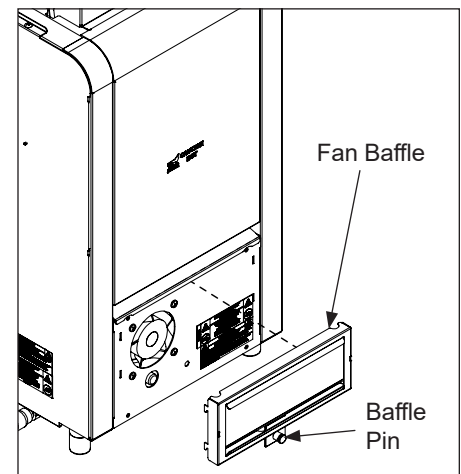

Figure 24. Pull baffle pin

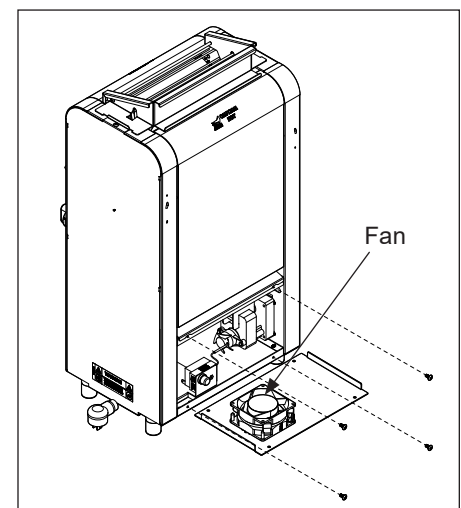

Figure 25. Rear fan

Troubleshooting

Problem	Possible Cause	Corrective Action
No Control Display	Power cord not plugged in	Plug power cord into the proper electrical outlet.
	Circuit breakers turned off or tripped. Damaged electrical outlet, plug, or cord. Power switch damaged	Reset circuit breakers. If they trip again, check the power cord, plug, and outlet for damage. Contact Antunes Technical Service, your maintenance person, or authorized service provider.
	Power Switch not turned on or is faulty.	Turn the unit off and then on again. If the problem persists, contact Antunes Technical Service, your maintenance person, or authorized service provider.
	Faulty Transformer	
Conveyor does not rotate	Conveyor Belt/Chain has stretched. Chain skipping on sprockets.	Measure and adjust the conveyor belt chains as described in the Maintenance section of this manual.
	Loose setscrew on one of the drive sprockets	Contact Antunes Technical Service, your maintenance person or authorized service provider.
	Motor Drive Chain loose	Contact Antunes Technical Service, your maintenance person or authorized service provider.
	Internal part /object interfering within conveyor system	Check for interference & clear up as necessary.
Conveyor(s) skips or hesitates	Conveyor chains loose.	Measure and adjust the conveyor belt chains as described in the Maintenance section of this manual.
	Belt wrap clip not attached.	Verify both clips on each belt wrap are attached, reattach if necessary.
	Roller tensioner not adjusted properly.	Measure the roller tensioner and adjust if necessary. See the Maintenance section of this manual.
	Loose or misaligned sprocket	Contact Antunes Technical Service, your maintenance person or authorized service provider.
	Motor drive chain loose or stretched	Contact Antunes Technical Service, your maintenance person or authorized service provider.
	Drive motor(s) have failed	Contact Antunes Technical Service, your maintenance person or authorized service provider.
Buns not toasting adequately	Compression settings are incorrect.	Use recommended setting or adjust compression knobs as needed to achieve desired toast quality.
	Release sheet is worn or needs cleaning (replace every 2-4 weeks).	Inspect release sheet for cleanliness, worn spots, wrinkles, or tears. Clean or replace release sheet as described in the Maintenance section of this manual.
	Platen has butter/debris buildup.	Clean Platen as described in the Maintenance section of this manual.
	Light/Dark setting needs to be adjusted.	Adjust light/dark setting. See Operation section of this manual.

Troubleshooting (Continued)

Problem	Possible Cause	Corrective Action
Crowns and/or Heels must be forced into the toaster. Buns sticking and burning.	Belt wraps are dirty, worn or damaged.	Clean or replace Belt Wraps as described in the Maintenance section of this manual.
	Platen has butter/debris buildup.	Clean Platen as described in the Maintenance section of this manual.
	Release sheet is dirty, worn or damaged.	Clean both sides or replace release sheet as described in the Maintenance section of this manual.
	Conveyor Chains loose.	Adjust the conveyor belt chains as described in the Maintenance section of this manual.
	Drive motor stalls intermittently.	Contact your Maintenance person or Authorized Service agency for service.
	Compression settings are incorrect.	Use the recommended settings or adjust as needed to achieve desired toast quality.
	Buns are not inserted into the toaster properly.	Insert Crowns in front conveyor with and Heels in rear conveyor. Cut side of buns need to face the platen.
Toaster making unusual sounds	Fan needs to be cleaned or replaced.	Clean fan as described in the Maintenance section of this manual or contact your maintenance person or authorized service company.
	Conveyor belt chains have stretched or adjusted incorrectly.	Adjust the conveyor belt chains as described in the Maintenance section of this manual.
	Motor Drive chain needs lubrication.	Lubricate chain.
	Conveyor shaft bearing is binding.	Contact your Maintenance person or Authorized Service agency for service.
Buns getting caught in bun chute area	Bun chute installed incorrectly	Reinstall Bun chute correctly.
Toaster displays ERR 10.	Internal temperature of control compartment exceeded 160° F.	Verify fan intake on back of toaster is clean, not blocked and has proper spacing. Clean cooling fan if needed, if not rotting, contact your authorized service provider. Check if cooling fan is functioning. If not, replace fan..
Toaster Displays ERR 11, 12, 15 or 17.	Electrical failure.	Perform a factory reset. Ensure power switch is in off position and press and hold Up & Down arrow buttons together while turning power switch on. Display will show FR (factory reset). If Error code continues to display, contact AJA technical service.

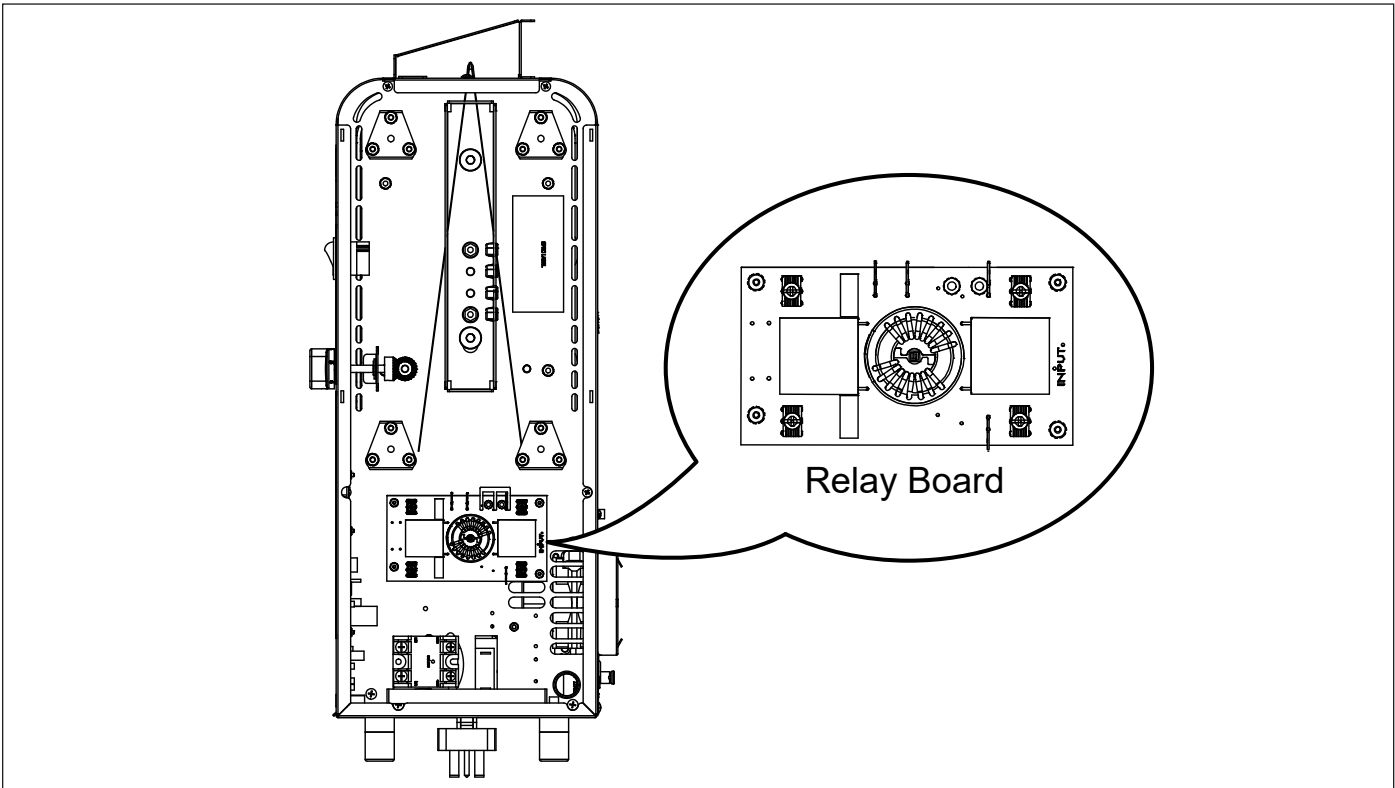
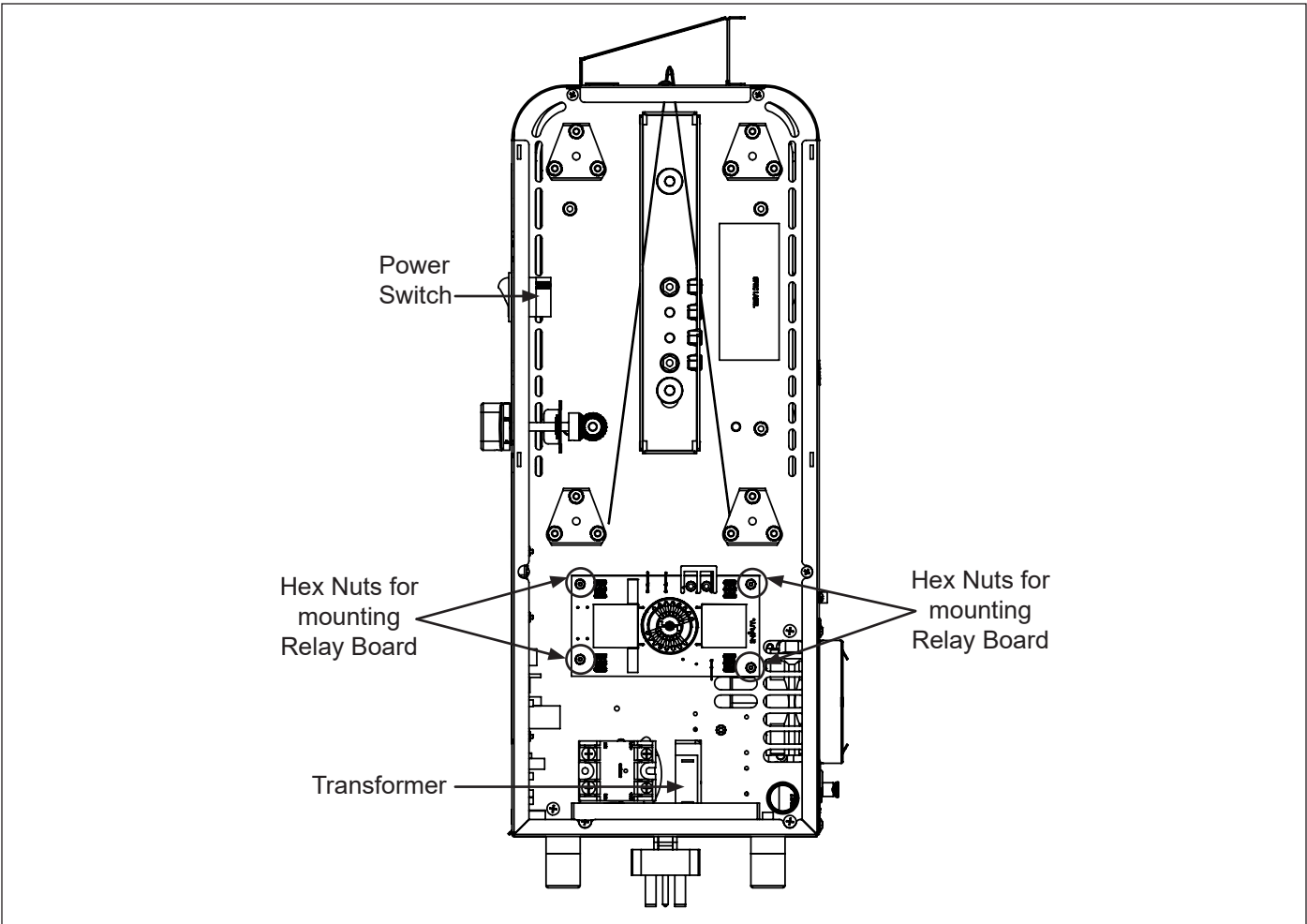

Replacement Parts

Parts List

(See Exploded Views for more information)

NOTICE
Use only genuine Antunes replacement parts in this unit. Use of parts other than those supplied by the manufacturer will void the warranty.

Item No.	Part #	Description	Qty.
1	0014048	Inner Spring Tensioner Assy	4
2	0012982	Conveyor Belt Assembly 37/2	2
3	0012988	Tensioner Assembly	4
4	0012989	Bun Feeder Assembly	1
5	0021961	Conveyor Cover Weldment	2
6	0021900	Idle Bearing Retainer Weldment (Incl. With kit 7001115 - Item 100)	1
7	0021959	Cam Weldment	2
8	0021960	Base Weldment	1
9	0021962	Control Panel Weldment	2
10	0021964	End Housing Weldment	1
11	0024445	Control Housing Weldment	1
12	0022040	Bun Chute Weldment	1
13	7000780	Platen, Grill 230V/1900W	1
14	0400147	Bushing, Shorty 7/8"	1
15	0400265	Bushing, Shorty 3/8"	4
16	0400437	Strain Relief, Rt Angle (9210922 ONLY)	1
	0400375	Strain Relief, Rt Angle (9210923 ONLY)	
17	0500464	Bearing Retainer	1
18	0503495	Bracket, Retainer Right	2
19	0503496	Bracket, Tensioner-Right	2
20	0503497	Bracket, Tensioner-Left	2
21	0503507	Bracket, Retainer Left	2
22	0506755	Retainer, Bearing	6
23	0508503	Plate, Motor	1
24	0508370	Panel, Electrical	1
25	0507180	Bracket, Trx-Hi-Limit	1
26	0700982	Power Cord, IEC-309	1
27	0800455	Rod, Knob (Heel)	1
28	0800457	Rod, Knob (Crown)	1
29	0800458	Rod, Support	4
30	0800460	Shaft, Drive	2
31	0800461	Shaft, Idler	2
32	1000900	Label - Warning	1
33	1001181	Label, Crown	2
35	1001550	Label, Control	1
36	1001551	Label, Install	1
37	1001552	Label, Cam (Heel)	1

Item No.	Part #	Description	Qty.
38	1001553	Label, Cam (Crown)	1
39	1002802	Label, Wiring Diagram	1
40	1001592	Label, Chain Tensioning	1
41	1031188	Spec Label (9210922 ONLY)	2
	1031556	Spec Label (9210923 ONLY)	2
42	2100230	Bumper, Recess W/Washer	4
43	2100348	Knob, 1/4" Shaft, Push-On	2
44	2110127	Ring, Retaining	8
45	2150384	Bearing Assy, High Temp 1 1/8" OD X 1/2" ID	2
46	2120147	Spacer, Leg	4
47	7000296	Ball Bearing Kit (2-Pak)	1
48	2150173	Sprocket, 25B12 5/16" Bore	1
49	2150179	Sprocket, 25B14 1/2" Bore (1 Incl. With kit 7001115)	3
50	7000224	Bearing & Retainer Kit	1
51	7000207	Sprocket Kit, 25B28 x 1/2" Bore Stepped Tooth	1
52	2150258	Bearing, Idler (Incl. With kit 7001115 - Item 100)	1
53	2150260	Spacer, Bearing	6
54	2150368	Miter Gear, 20° Pressure Angle	4
55	2150370	Chain, Drive	1
56	2180145	Cover, Bumper	4
57	3000124	"Ring, Retaining 3/8" (Incl. with kit 7001115, Item 100)	1
58	3040105*	Nut, Hex 'Keps' #4-40	2
59	3060121*	Screw, Mach #6-32 X 3/4"	2
60	3060123*	Screw, Mach #6-32 X 7/8" Slrhdhd	4
61	3060130*	Nut, Hex Keps #6-32 (Small Pattern)	8
62	3060156*	Screw, Mach. #6-32 X 1/2"	2
63	3080115*	Screw, Mach. #8-32 X 3/8"	8
64	3080143*	Nut, Hex 'Keps' #8-32	8
65	3080144*	Screw, #8-32 X 1/4" (#6 Head)	16
66	3080157*	Screw, Tap 8-32 X 3/8"Lg	4
67	3080203*	Screw, Tap 8-32 X 3/8" W/Int. Tooth Washer	26
68	3100103*	Screw, Mach. #10-32 X 1/4"	4
69	3100136*	Screw, Mach. #10-32 X 1/4"	4
70	3100146*	Nut, Hex 'Keps' #10-32	26
71	3100213*	Screw, Phphhd #10-16 X 3/4" Thrd Form	4
72	3250104*	Washer, Flat 1/4" S/S	4
74	3250203*	Washer, Spring Steel Single-Wave	8
75	3380116	Screw, Shoulder 3/8-16 X 3/8 W/ 1/2 Shoulder	4
76	4000167	Motor, Gear 230 V 9RPM 50/60HZ	1

Replacement Parts (Continued)

Item No.	Part #	Description	Qty.
77	4000202	Fan, Axial 230V	1
78	4010187	Transformer, 240 Vac/12Vac	1
79	4010245	Rocker Switch	1
80	4030332	Thermostat, Hi-Limit	1
81	4050214	Thermocouple Type "K" (Open End)	1
82	4051063	Relay, Random Phase, Solid State	1
83	4060234	Wire Strap - 3/7"	1
84	4060303	Bus Bar Contact 3-Pole	1
86	4070202	Assy-Pbc, Display	1
88	7002037	Black Wavy Silicon Hook Belt (2 pack)	1
93	3080102*	Washer, Int. Tooth #09 Steel; Zinc Plated	4
96	3080181*	Screw, Mach. #8-32 X 3/8" Lg Phflthd, 18-8 S/S Brt	4
97	7000779	Rail, Slide Kit (Large)	1
98	0400436	Sheet, Platen Cover	1
100	7001115	Idler Sprocket Replacement Kit	1
101	4070383	Board, Line Filter	1
102	0022789	Air Filter Weldment	1
103	0013260	Drive Chain Tensioner	1
104	0600155	Compression Setting Spring	1
99	7001084	Cleaning Tool Kit - VCT-2	1
100	7001115	Idler Sprocket Replacement Kit	1
101	7001372	Relay Board Kit	1
102	7001602	Baffle Kit	1
103	7001529	Drive Chain Tensioner	1
104	0600155	Compression Setting Spring	1
105	1070014	Label - QR Code, VCT-2 (9210922 ONLY)	
106	3100157	Washer, Flat #10	4
107	3100224	Set Screw, Knurl Grip Cup Point, 10-32 UNF-2A X 1/4"	1
108	4060355	Terminal Block 3 Pole	1
109	3060101	Nut, Hex #6-32 St. Stl	2
110	0701106	VCT-2 Int. Wire Set	1
111	5206004	Tape, PTFE 10 Mil X 1WD X 18 YDS - 500 Deg. F	A/R
112	0600179	Extension Spring	4

* Item available in packages of ten (10).

Replacement Parts

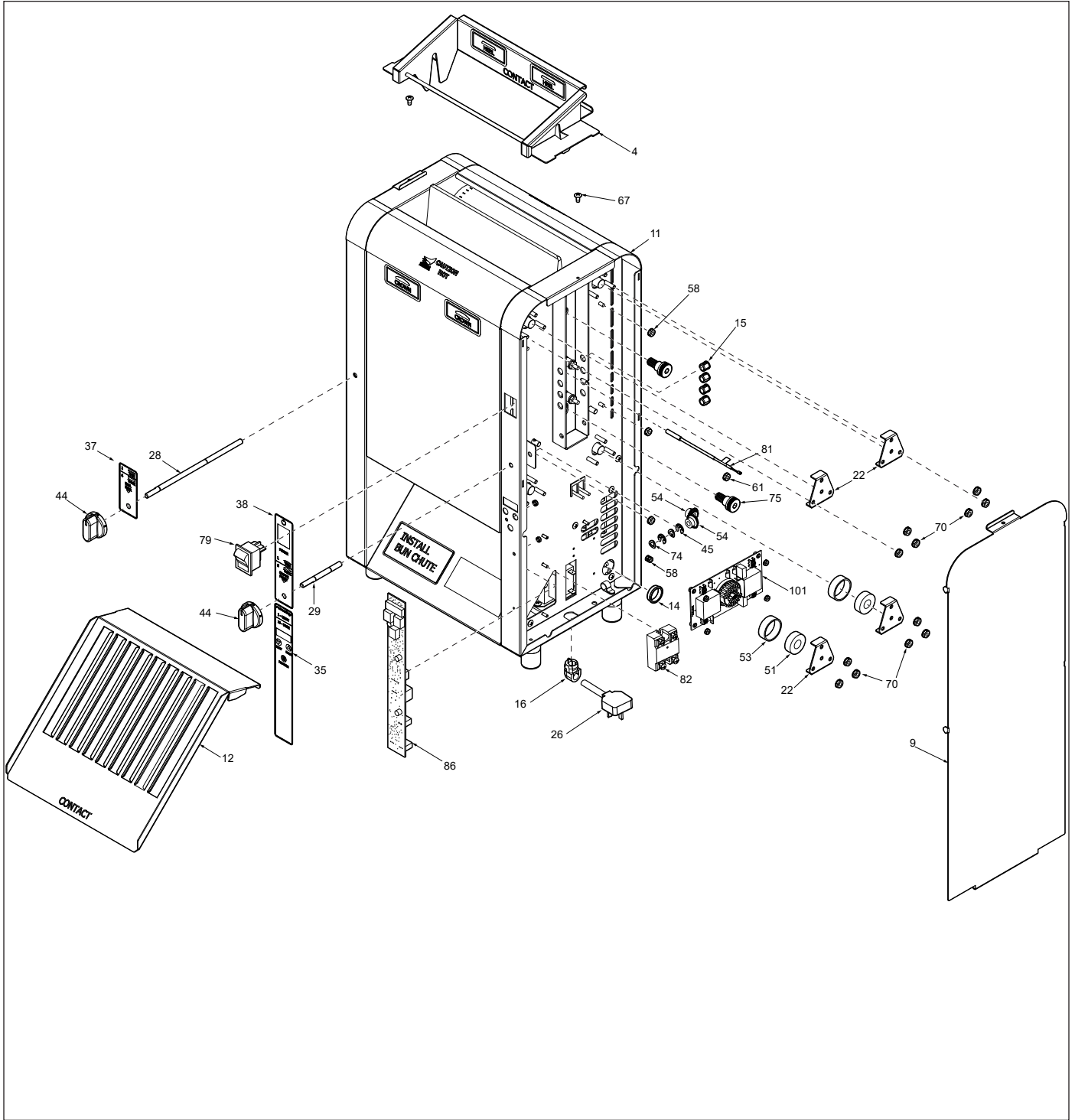

Replacement Parts (continued)

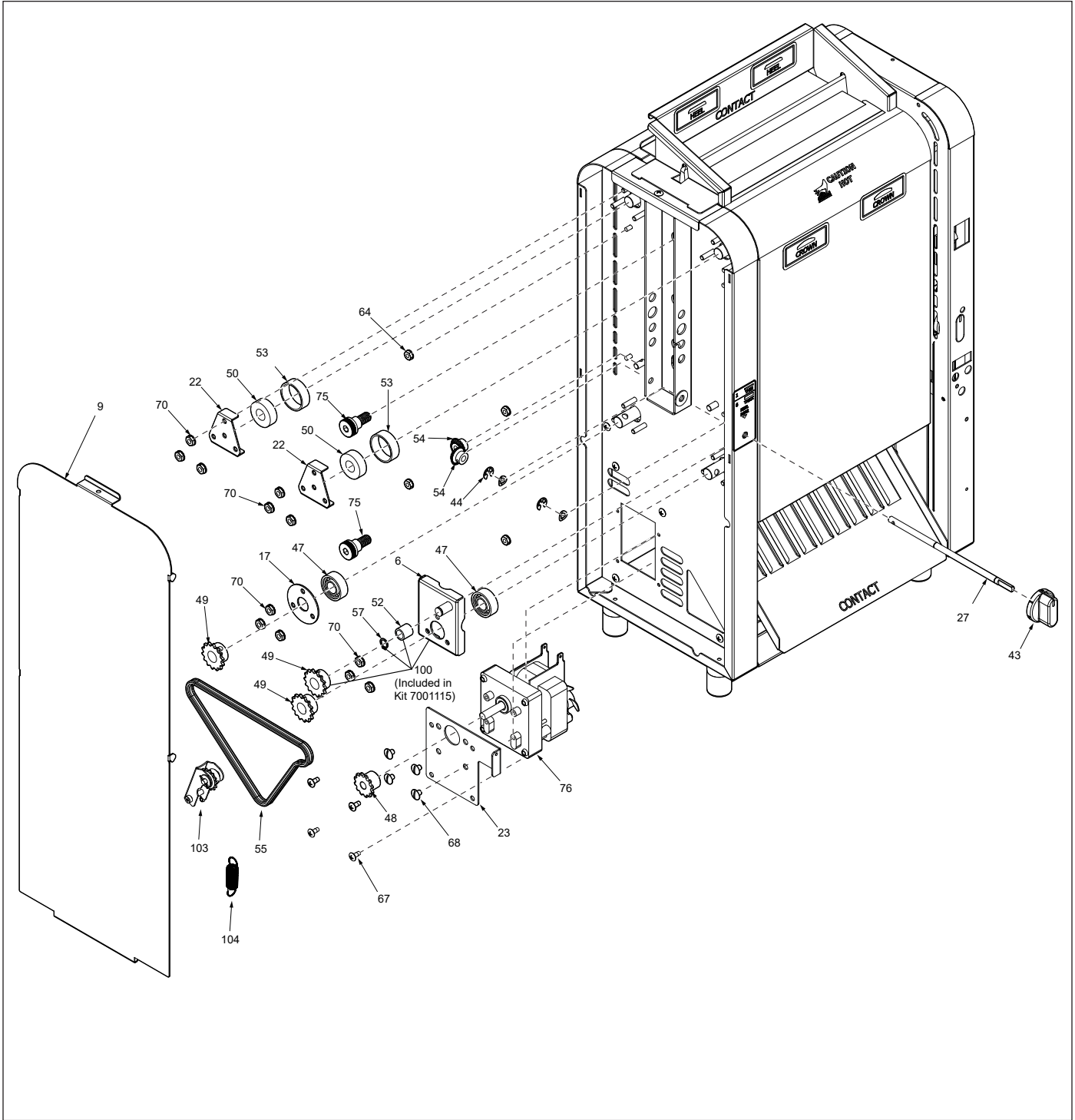

Replacement Parts (Continued)

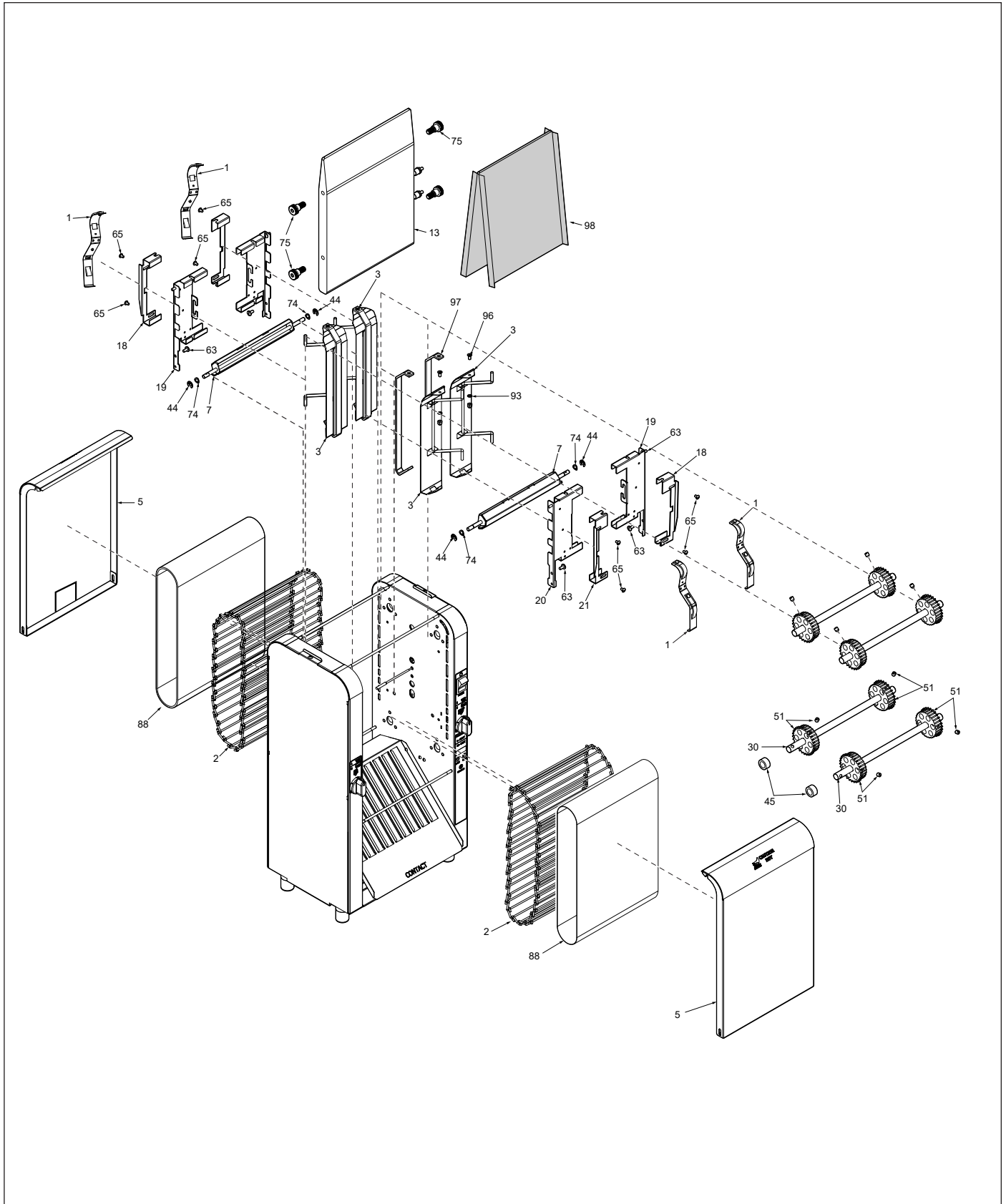

Replacement Parts (Continued)

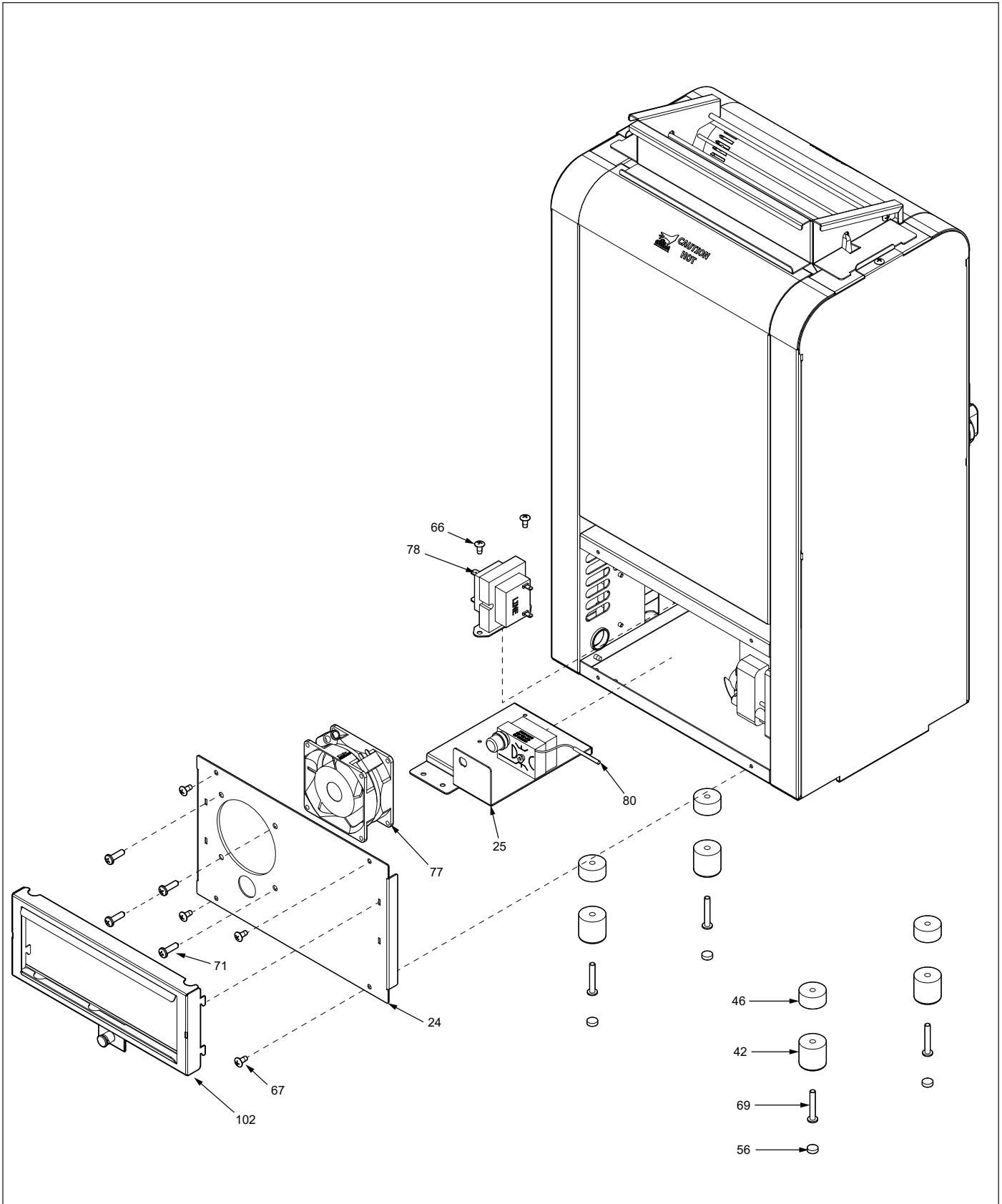

Wiring Diagram

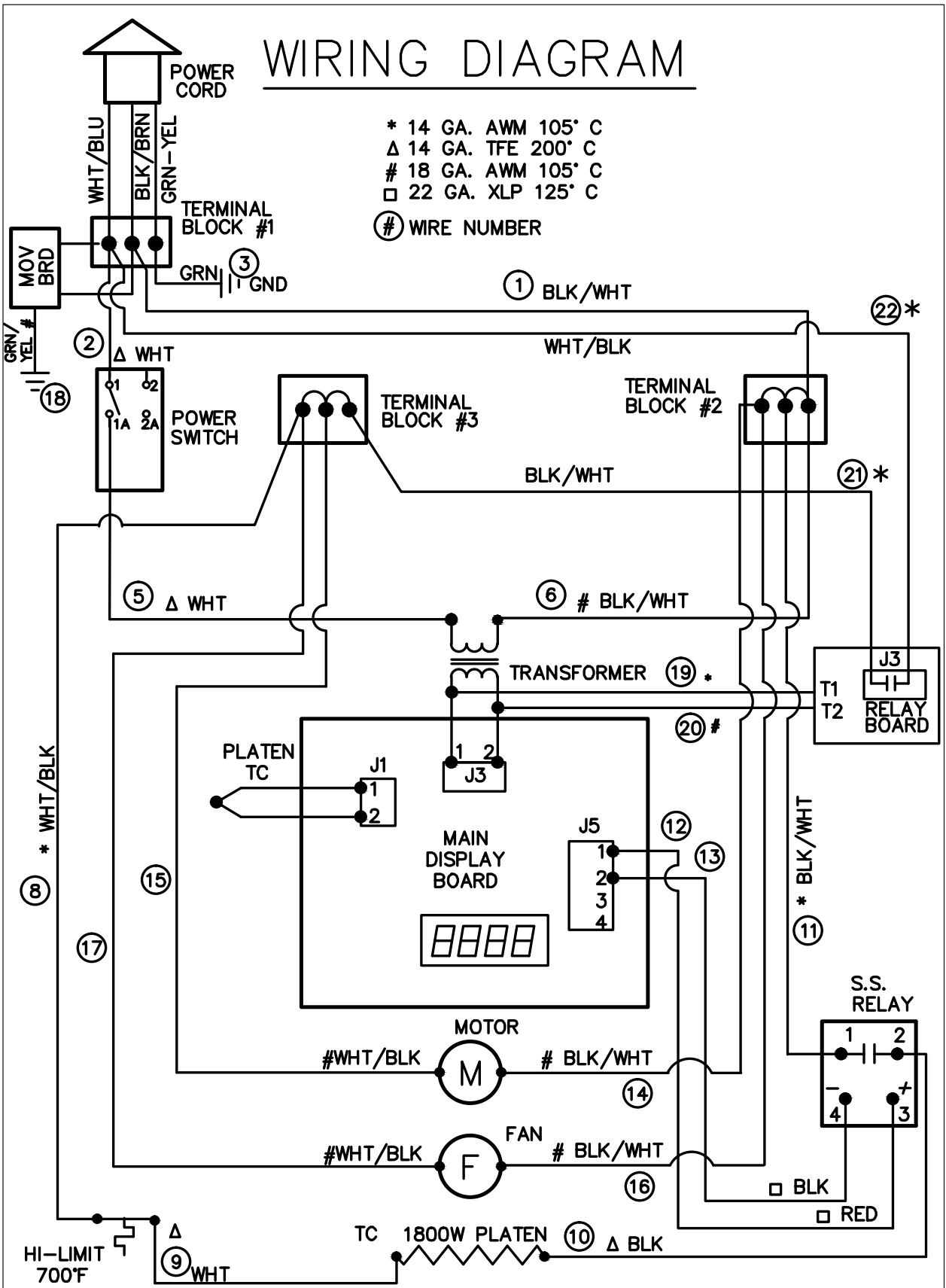

Limited Warranty

Equipment manufactured Antunes has been constructed of the finest materials available and manufactured to high quality standards. These units are warranted to be free from electrical and mechanical defects for a period of two (2) years from date of purchase under normal use and service, and when installed in accordance with manufacturer's recommendations. To insure continued operation of the units, follow the maintenance procedures outlined in the Owner's Manual. During the first 12 months, electromechanical parts, non-overtime labor, and travel expenses up to 2 hours (100 miles/160 km), round trip from the nearest Authorized Service Center are covered. During the second year of this warranty (months 12 - 24), the following items are covered by a Part Only warranty: Drive Motor, Control Board, and Platen Heater.

This warranty does not cover cost of installation, defects caused by improper storage or handling prior to placing of the Equipment. This warranty does not cover overtime charges or work done by unauthorized service agencies or personnel. This warranty does not cover normal maintenance, calibration, or regular adjustments as specified in operating and maintenance instructions of this manual, and/or labor involved in moving adjacent objects to gain access to the equipment. This warranty does not cover consumable/wear items such as Release Sheets, Conveyor Belt Chain Link removal, Belt Wraps, and Dampers. This warranty does not cover damage to the Platen due to operating the toaster without a Release Sheet or cleaning with abrasive cleansers or tools, misuse or dropping of unit. This warranty does not cover problems or failures resulting from improper/incorrect voltage supply. This warranty does not cover Travel Time & Mileage in excess of 2 hours (100 miles/160 km) round trip from the nearest authorized service agency.

Antunes reserves the right to make changes in design or add any improvements on any product. The right is always reserved to modify equipment because of factors beyond our control and government regulations. Changes to update equipment do not constitute a warranty charge.

If shipment is damaged in transit, the purchaser should make a claim directly upon the carrier. Careful inspection should be made of the shipment as soon as it arrives and visible damage should be noted upon the carrier's receipt. Damage should be reported to the carrier. This damage is not covered under this warranty.

Warranty charges do not include freight or foreign, excise, municipal or other sales or use taxes. All such freight and taxes are the responsibility of the purchaser.

This warranty is exclusive and is in lieu of all other warranties, expressed or implied, including any implied warranty or merchantability or fitness for a particular purpose, each of which is hereby expressly disclaimed. The remedies described above are exclusive and in no event shall Antunes be liable for special consequential or incidental damages for the breach or delay in performance of this warranty.



Corporate Headquarters
Carol Stream, IL, USA
Phone: +1.630.784.1000
Toll Free: +1.800.253.2991
Fax: + 1.(630).784-1650

China Facility
Suzhou, China
Phone: +84.512.6841.3637
Fax: +86.512.6841.3907

India Facility
Chennai, India
Phone: +91.44.25532212
Fax: +91.44.25532415