



THE VERSATILE POWER OF STEAM

The Antunes Deluxe Food Warmer converts tap water into steam to quickly heat and serve sandwiches - keeping their original textures, flavors and nutrients. The end result: food that looks fresher and tastes better.

The Deluxe Food Warmer instantly creates steam with the simple push of a button. Producing a consistent amount of steam, the Deluxe Food Warmer removes the guesswork, delivering a uniform finished product from one operator the next.



Deluxe Food Warmer DFW-150



Fully Programmable

Easily adjust the time, number of steam shots, and amount of steam to ensure the best results.



Easy Installation

This compact design is available with a direct water hook-up or self-contained water reservoir for flexibility in installation.

Deluxe Food Warmer | DFW

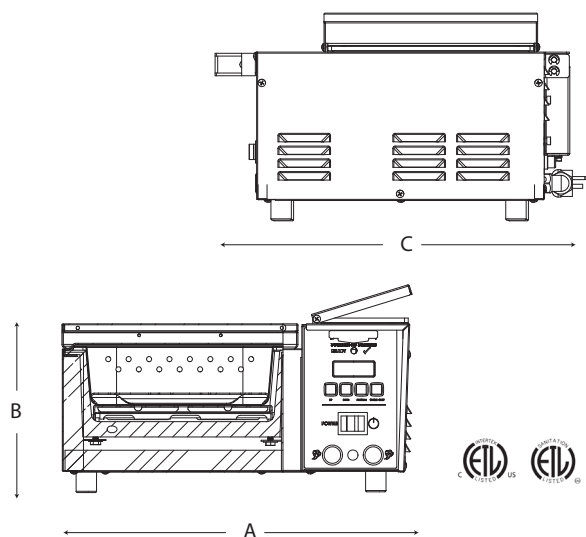

Features:

- Open compartment delivers steam from all sides
- Instantly turns plain tap water into steam
- 0-99 minute timed steam cooking with instant warming button
- Fully adjustable pulse of steam
- Available with a self-contained water reservoir or direct water hookup

NOTE: Units with a direct water hookup require a water pressure regulator. The psi should be between 20 and 30 psi (1.4 - 2.06 bar)

DFW

Electrical Ratings

Dimensions

Model & Mfg. No.	Capacity	Approvals	Plug	Volts	Watts	Amps	Hz.	Width (A)	Depth (B)	Height (C)	Shipping Weight
DFW-150 9100169	Half-size 2 7/8" (73 mm) deep pan		NEMA 5-15P	120	1800	15	50/60	16 5/8" (422 mm)	17 1/4" (438 mm)	8 3/4" (222 mm)	42 lbs. (19.1 kg)
DFW-250 9100162	Half-size 2 7/8" (73 mm) deep pan		NEMA 5-15P	120	1800	15	50/60	16 5/8" (422 mm)	17 1/4" (438 mm)	8 1/4" (210 mm)	45 lbs. (20.4 kg)

Dimensions are for item without shipping box. Shipping weight includes item and shipping box.



DFW-150



DFW-250