

InfiniSteam Next Generation | IS-1000



STEAMED TO PERFECTION EVERY TIME

The InfiniSteam Next Generation steamer combines high-performance boiler technology with cutting-edge control and sensing design for a precision steaming experience unlike any other. The InfiniSteam's always-ready operation provides operators continuous steaming with zero recovery delay and delivers accelerated cook times with a single touch.

The InfiniSteam uses dry steam to prepare sandwich proteins that look fresher, taste better, and are ready sooner. With two independent steaming zones in easy-to-clean removable drawers and a stacking-capable design, the InfiniSteam brings speed and efficiency to any kitchen configuration. A smart touch-operated graphic interface allows operators to easily steam, check status, and automate cleaning cycles. With the InfiniSteam, kitchen capabilities extend far beyond the conventional.



InfiniSteam IS-1000



Versatile Menu

Perfect for retherming sandwich builds, mac 'n' cheese, and other items.



Boost Efficiency

Continuous steaming with no recovery time from high-performance boiler technology.



Independent Settings

Each drawer is independently programmable -- contents, status, temperature and holding time.



FOUNDED BY FIREMEN

InfiniSteam Next Generation | IS-1000

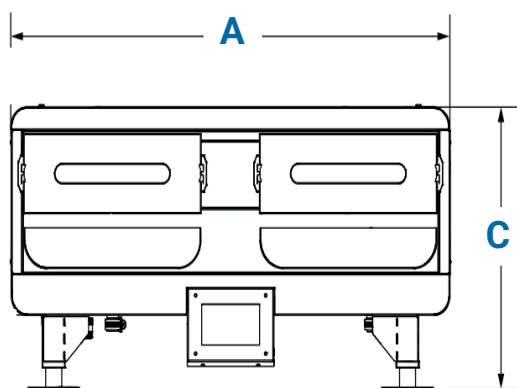

Features:



- The boiler delivers high-temperature, high-pressure steam for fast retherming
- Turns plain tap water into steam
- Fast 1:30 min cycle time for hot, moist sandwich proteins and gooey melted cheese
- Fully adjustable pulse of steam

NOTE: Requires high quality, low mineral content water at 40-45 psig dynamic pressure

IS-1000

Electrical Ratings

Dimensions

Model & Mfg. No.	Capacity	Approvals	Plug	Volts	Watts	Amps	Hz.	Width (A)	Depth (B)	Height (C)	Shipping Weight
IS-1000 9100960	Two 8" (203 mm) wide and 10.5" (267 mm) deep steam drawers	 	NEMA 6-50P	208	8000	38	50/60	29.75" (756 mm)	25.95" (654 mm)	15.25" (387 mm)	120 lbs. (54.4 kg)

Dimensions are for item without shipping box. Shipping weight includes item and shipping box.