

BOX LABEL
(PROVIDED BY ANTUNES)
ANTUNES PN 1002917
ON OUTSIDE OF
SOFTENER BOX
SEE NOTE 6

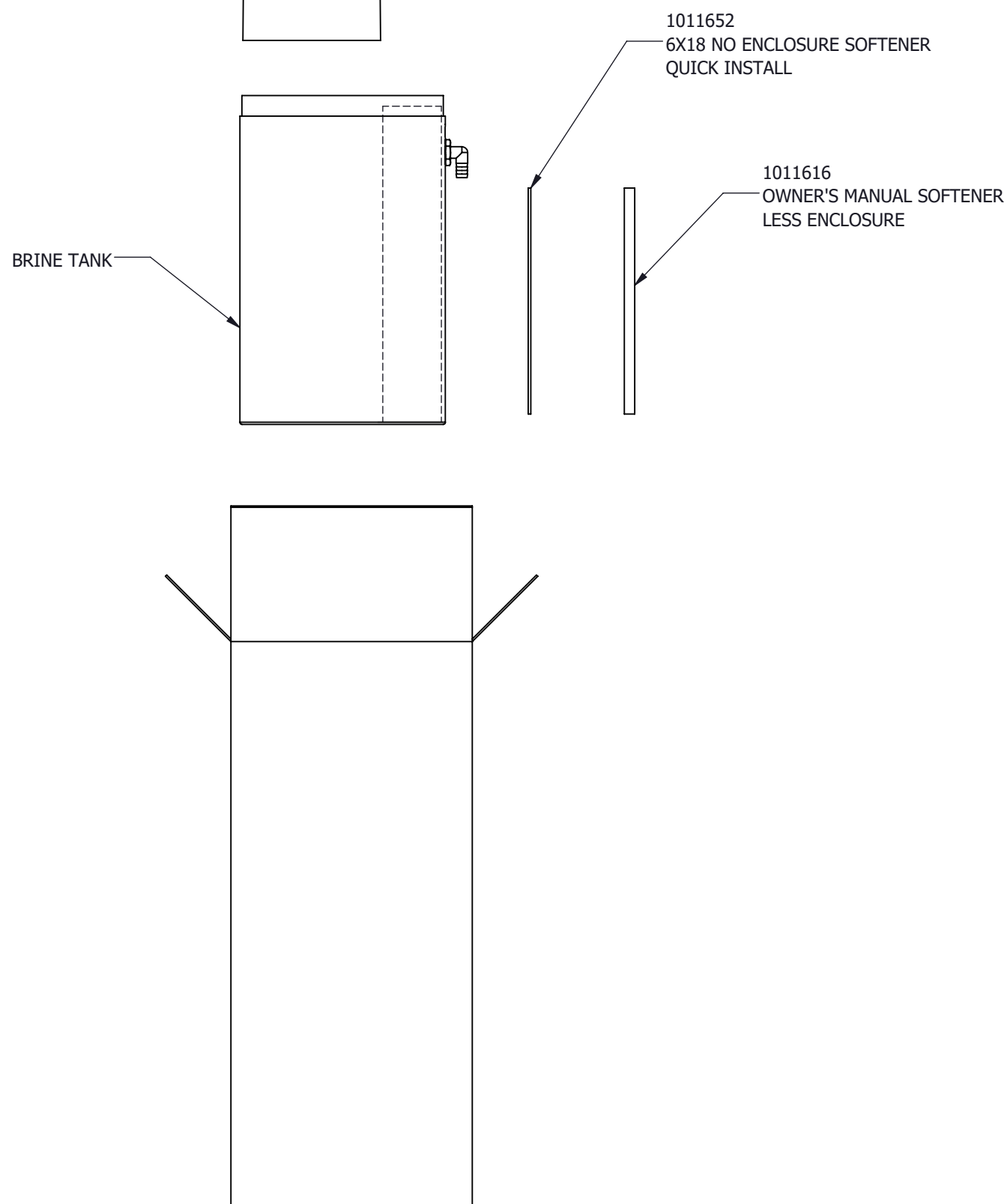
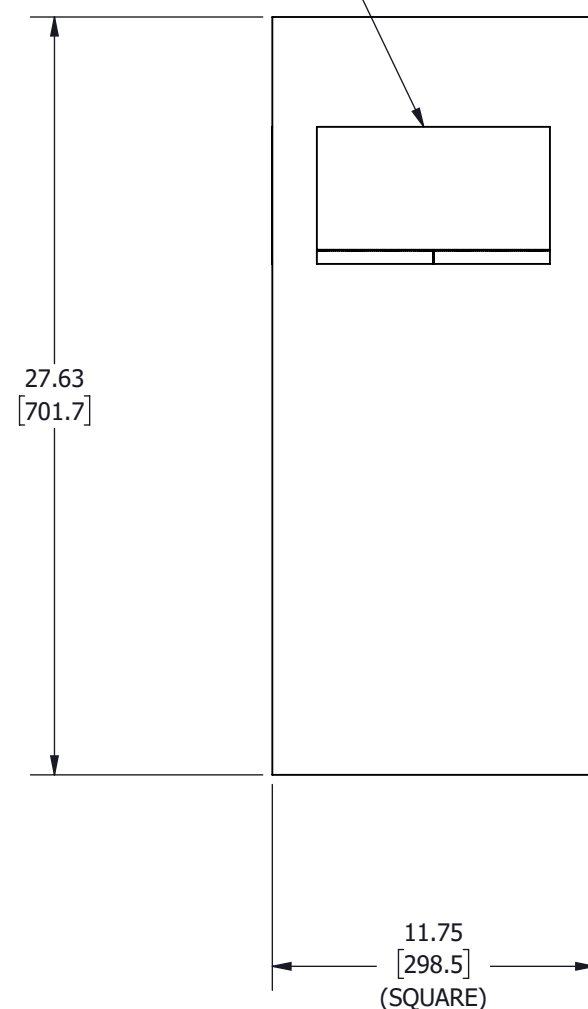
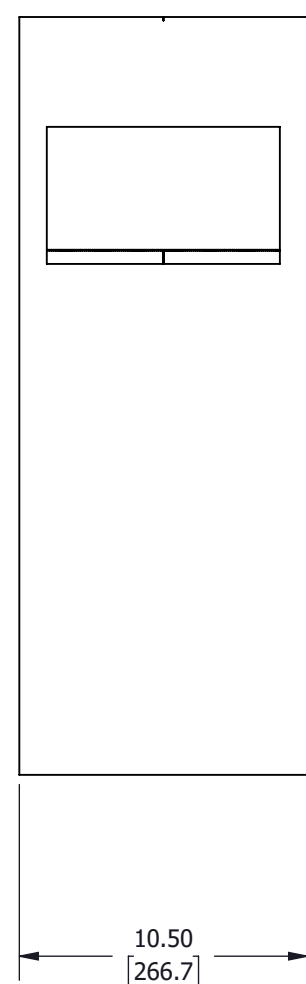

PACKAGING NOTES:

1. BOX LABELS TO BE APPLIED TO THE OUTSIDE OF BOX.
2. BUBBLE WRAP AND PAPER PACKAGING AS REQUIRED.

NOTES:

1. PERFORMANCE WATER PART NUMBER AL6185600SXTMTRBK1016SBVHFBP75
2. SOFTENER TANK COMES WITH MEDIA & PIPE RISER PRE-LOADED IN THE PRESSURE TANK AND THE CONTROL VALVE INSTALLED ON THE TANK.
3. LABELING PROVIDED BY ANTUNES AND APPLIED BY VENDOR (SEE SHEET 3).
4. BRINE SYSTEM COMES WITH BRINE VALVE PRE-INSTALLED IN THE BRINE TANK (SEE DRAWING 2090319, SHT 3).
5. SERIAL NUMBER ON SPEC LABEL **MUST** MATCH SERIAL NUMBER ON BOX LABEL.
6. ONLY ANTUNES PROVIDED LABELING & DOCUMENTATION INCLUDED WITH SYSTEM. NO SUPPLIER OR OTHER LABELING TO BE INCLUDED.

ITEM NO.	PART NUMBER	DESCRIPTION	QTY.
1	2090319	6X18 SOFT & BRINE SYSTEM	1
2	7002387	LABEL KIT, 9710145	1

REV	DATE	PCO NO.	DESCRIPTION	BY
A	4/9/21	PDR00253	INITIAL RELEASE	RF

THE INFORMATION AND DESIGNS CONTAINED IN THIS DRAWING ARE CONFIDENTIAL AND THE PROPRIETARY PROPERTY OF A.J. ANTUNES & CO. NEITHER THIS DESIGN NOR ANY INFORMATION CONTAINED HEREIN MAY BE REPRODUCED OR DISCLOSED TO OTHERS WITHOUT THE EXPRESS WRITTEN CONSENT OF A.J. ANTUNES & CO.

UNLESS OTHERWISE SPECIFIED: INTERPRET DIMENSIONS AND TOLERANCES PER ASME Y14.5-2009 ALL DIMENSIONS: INCH [mm] TOLERANCES: FRACTIONS: ±1/32" [8mm] DECIMAL: .xx ±.01" [.25mm] .xxx ±.005" [.125mm] ANGULAR: ±1°		DRAWN BY: RF	APVD BY:	
DATE: 4/9/2021		DATE:		
PART DESCRIPTION: 6X18 SOFTENER W/ BRINE				SHEET 1 OF 3
MATERIAL SPECIFICATION:				
SIZE: c	SCALE: 1:7	PART NUMBER: 9710145	REV: A	

NO BURRS ALLOWED
BREAK ALL SHARP CORNERS

DO NOT SCALE DRAWING

THIRD ANGLE PROJECTION

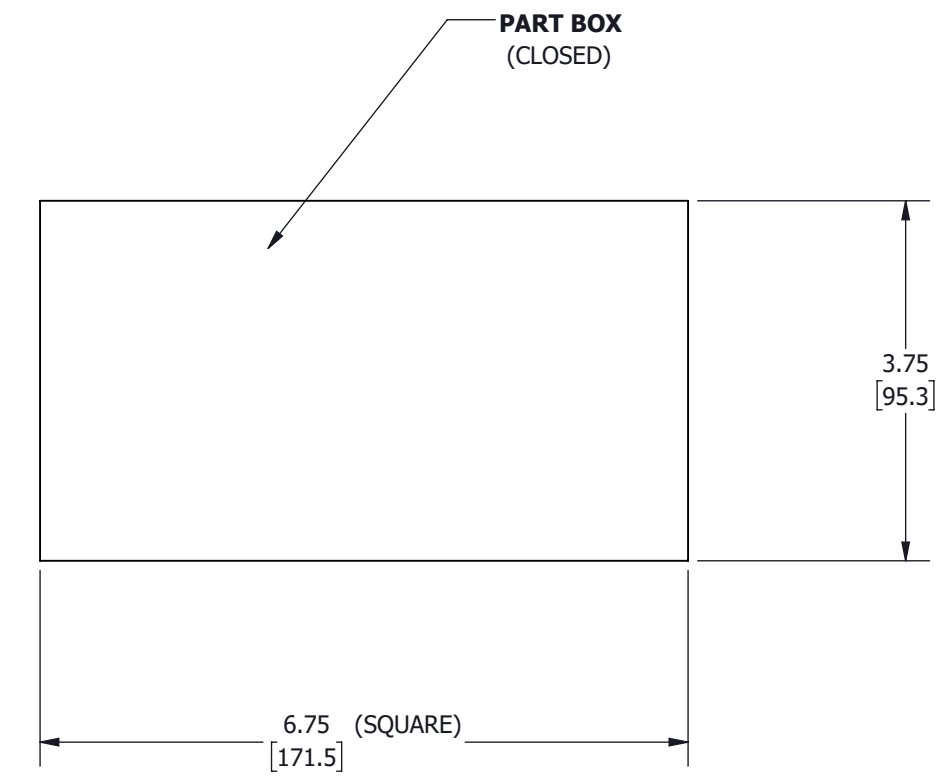
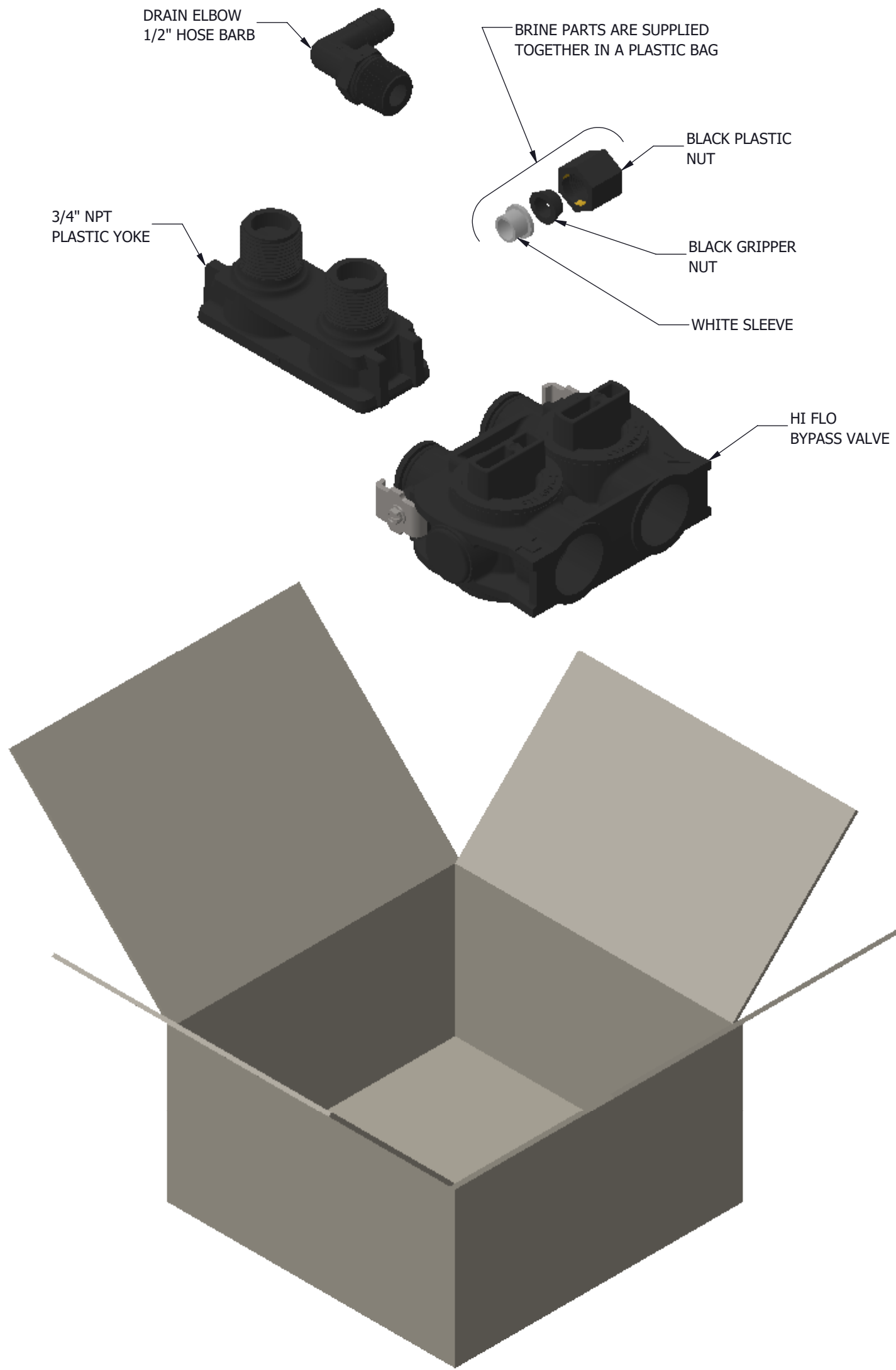

THE INFORMATION AND DESIGNS CONTAINED IN THIS DRAWING ARE CONFIDENTIAL AND THE PROPRIETARY PROPERTY OF A.J. ANTUNES & CO. NEITHER THIS DESIGN NOR ANY INFORMATION CONTAINED HEREIN MAY BE REPRODUCED OR DISCLOSED TO OTHERS WITHOUT THE EXPRESS WRITTEN CONSENT OF A.J. ANTUNES & CO.

UNLESS OTHERWISE SPECIFIED: INTERPRET DIMENSIONS AND TOLERANCES PER ASME Y14.5-2009 ALL DIMENSIONS: INCH [mm] TOLERANCES: FRACTIONS: ±1/32" [.8mm] DECIMAL: .xx ±.01" [.25mm] .xxx ±.005" [.125mm] ANGULAR: ±1°	DRAWN BY: RF	APVD BY:	
	DATE: 4/9/2021	DATE:	
NO BURRS ALLOWED BREAK ALL SHARP CORNERS			PART DESCRIPTION: 6X18 SOFTENER W/ BRINE
THIRD ANGLE PROJECTION			MATERIAL SPECIFICATION:
DO NOT SCALE DRAWING	SIZE: C	SCALE: 1:4	PART NUMBER: 9710145
			REV: A

SHEET 2 OF 3



SPEC LABEL
(PROVIDED BY ANTUNES)
ANTUNES PN 1031663
1/2" BELOW TOP EDGE & CENTERED
ON BACK SIDE OF VALVE
SEE NOTE 6

VALVE & ASSOCIATED COMPONENTS SHIP
LOOSE IN SEPARATE BOX (SEE SHEET 2)

ANTUNES BRAND LABEL
(PROVIDED BY ANTUNES)
ANTUNES PN 1002749

TANK COMES PRELOADED WITH:
MEDIA, RISER PIPE, & LOWER DISTRIBUTOR
& CONTROL VALVE ASSEMBLED

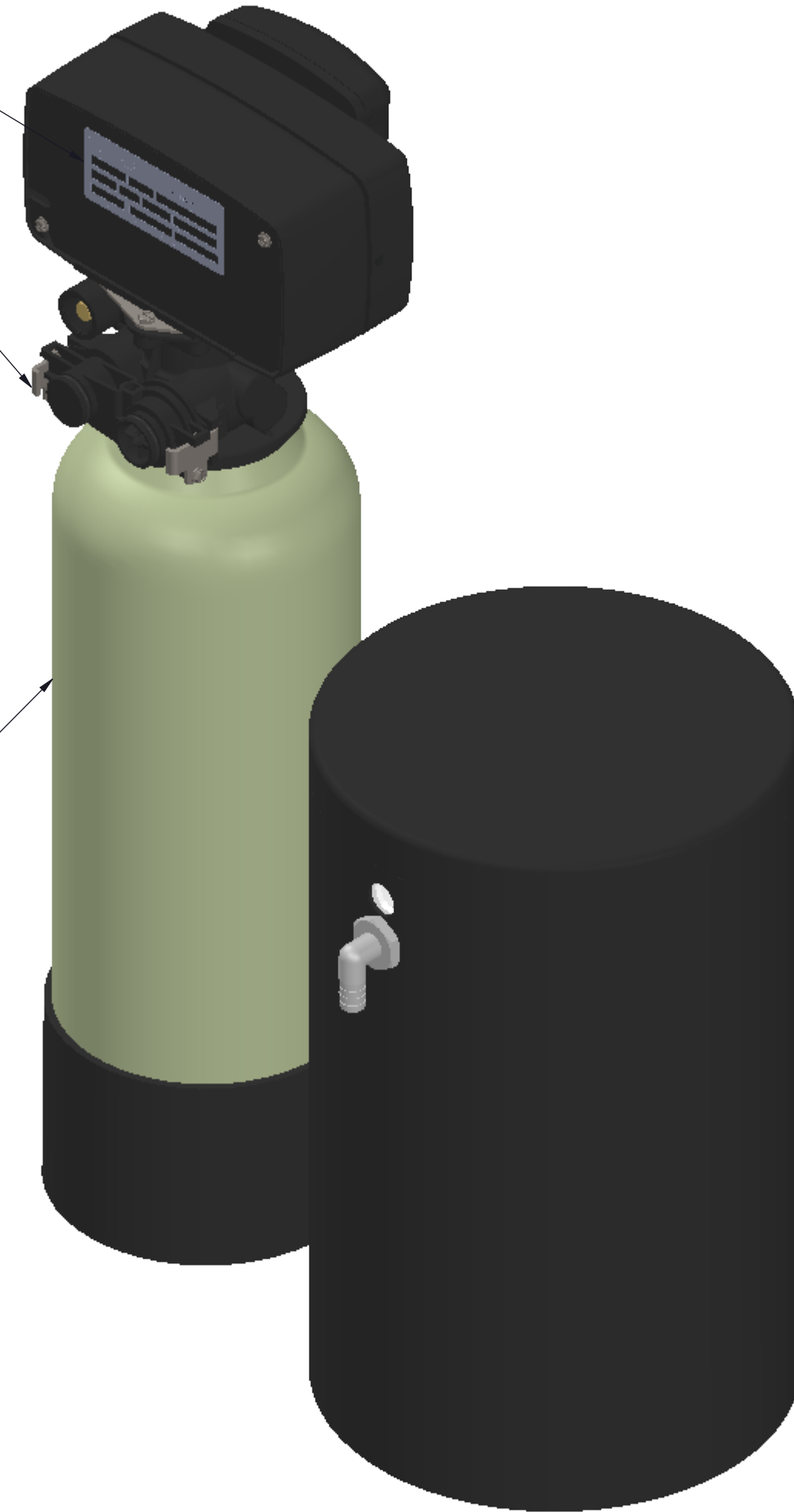

- NOTES:**
- PARTS TO BE WRAPPED IN BUBBLE WRAP AS REQUIRED.
 - ANTUNES PROVIDED LABELS TO BE APPLIED TO CONTROL VALVE PRIOR TO PACKING INTO BOX.

THE INFORMATION AND DESIGNS CONTAINED IN THIS DRAWING ARE CONFIDENTIAL AND THE PROPRIETARY PROPERTY OF A.J. ANTUNES & CO. NEITHER THIS DESIGN NOR ANY INFORMATION CONTAINED HEREIN MAY BE REPRODUCED OR DISCLOSED TO OTHERS WITHOUT THE EXPRESS WRITTEN CONSENT OF A.J. ANTUNES & CO.

UNLESS OTHERWISE SPECIFIED: INTERPRET DIMENSIONS AND TOLERANCES PER ASME Y14.5-2009 ALL DIMENSIONS: INCH [mm] TOLERANCES: FRACTIONS: ±1/32" [8mm] DECIMAL: .xx ±.01" [.25mm] .xxx ±.005" [.125mm] ANGULAR: ±1°	DRAWN BY: RF	APVD BY:	
	DATE: 4/9/2021	DATE:	
PART DESCRIPTION: 6X18 SOFTENER W/ BRINE			SHEET 3 OF 3
MATERIAL SPECIFICATION:			
	DO NOT SCALE DRAWING	SIZE: c	SCALE: 1:7
PART NUMBER: 9710145		REV: A	