

## InfiniSteam Next Generation | IS-1000



# STEAMED TO PERFECTION EVERY TIME

The InfiniSteam Next Generation steamer combines high-performance boiler technology with cutting-edge control and sensing design for a precision steaming experience unlike any other. The InfiniSteam's always-ready operation provides operators continuous steaming with zero recovery delay and delivers accelerated cook times with a single touch.

The InfiniSteam uses dry steam to prepare sandwich proteins that look fresher, taste better, and are ready sooner. With two independent steaming zones in easy-to-clean removable drawers and a stacking-capable design, the InfiniSteam brings speed and efficiency to any kitchen configuration. A smart touch-operated graphic interface allows operators to easily steam, check status, and automate cleaning cycles. With the InfiniSteam, kitchen capabilities extend far beyond the conventional.



InfiniSteam IS-1000



### Versatile Menu

Perfect for retherming sandwich builds, mac 'n' cheese, and other items.



### Boost Efficiency

Continuous steaming with no recovery time from high-performance boiler technology.



### Independent Settings

Each drawer is independently programmable -- contents, status, temperature and holding time.



FOUNDED BY FIREMEN

# InfiniSteam Next Generation | IS-1000

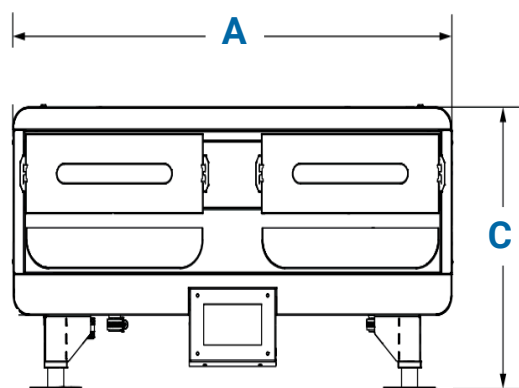

## Features:

- The boiler delivers high-temperature, high-pressure steam for fast retherming
- Turns plain tap water into steam
- Fast 1:30 min cycle time for hot, moist sandwich proteins and gooey melted cheese
- Fully adjustable pulse of steam

NOTE: Requires high quality, low mineral content water at 40-45 psig dynamic pressure



### IS-1000

### Electrical Ratings

### Dimensions

Model & Mfg. No.	Capacity	Approvals	Plug	Volts	Watts	Amps	Hz.	Width (A)	Depth (B)	Height (C)	Shipping Weight
IS-1000 9100960	Two 8" (203 mm) wide and 10.5" (267 mm) deep steam drawers		NEMA 6-50P	208	8000	38	60	29.75" (756 mm)	25.95" (654 mm)	15.25" (387 mm)	120 lbs. (54.4 kg)

Dimensions are for item without shipping box. Shipping weight includes item and shipping box.