

## Corn Cooker | CCC



# EXPAND YOUR MENU WITH COUNTERTOP COOKING

The Antunes Corn Cooker is designed to elevate your kitchen operations by eliminating guesswork while maintaining food quality.

Make every meal feel home cooked by serving it with a perfectly fresh ear of corn. The Corn Cooker uses a preset cooking time and low temperature heater to ensure the corn on the cob consistently looks, tastes, and smells fresh for up to five hours.



CCC--20 Corn Cooker



### Built to Last

Heavy duty stainless steel construction



### Keeps Corn Fresh

Holds quality corn for up to five hours at the perfect temperature



# Corn Cooker | CCC

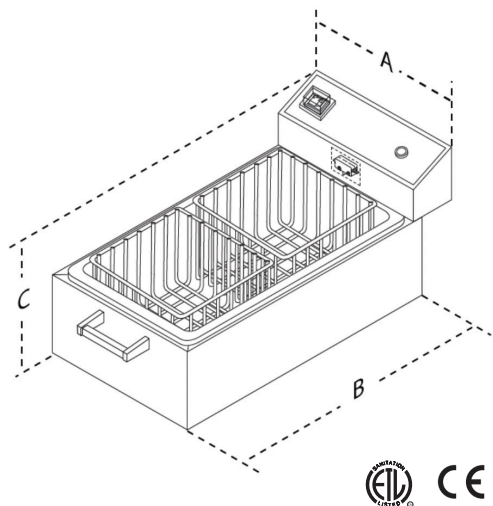

## Features:

- Holds up to eight 3" (76 mm) ears of corn or forty 6" (152 mm) ears of corn
- Stainless steel construction
- Low temperature, thermostatically controlled
- Uses plain tap water
- Easy to clean

### CCC

### Electrical Ratings and Plug Configurations

### Dimensions

Model & Mfg. No.	Approvals	Plug	Volts	Watts	Amps	Hz.	Width	Depth	Height	Shipping Weight
CCC-20 9600215		CEE 7/7	208-240	1570-2090	7.5-8.7	50/60	13" (330 mm)	25" (635 mm)	14 1/8" (359 mm)	33 lbs. (15 kg)
CCC-20 9600221		BS-1363	230	2090	13	50/60	13" (330 mm)	25" (635 mm)	14 1/8" (359 mm)	33 lbs. (15 kg)